

Scientific Report 2012 | 2013





Members of the research group Systems-oriented Immunology and Inflammation Research (SIME) discuss the identification of novel interaction partners of the transcriptional co-factor $I\kappa B_{NS}$ that was identified as a crucial protein regulating the differentiation of T lymphocytes. From left: Dr. Marc Schuster, Alisha Walker and Prof. Dr. Ingo Schmitz.

HZI / Hallbauer & Fioretti



After performing site-directed gene mutagenesis, the PhD student Wiebke Opitz is checking growth of Yersinia pseudotuberculosis mutant clones on a selective medium plate. HZI



Here you can download the complete
Scientific Report 2012 | 2013

Scientific Report **2012** | **2013**

- 04 Portrait of the HZI
- 06 Foreword
- 10 Programme Infection Research

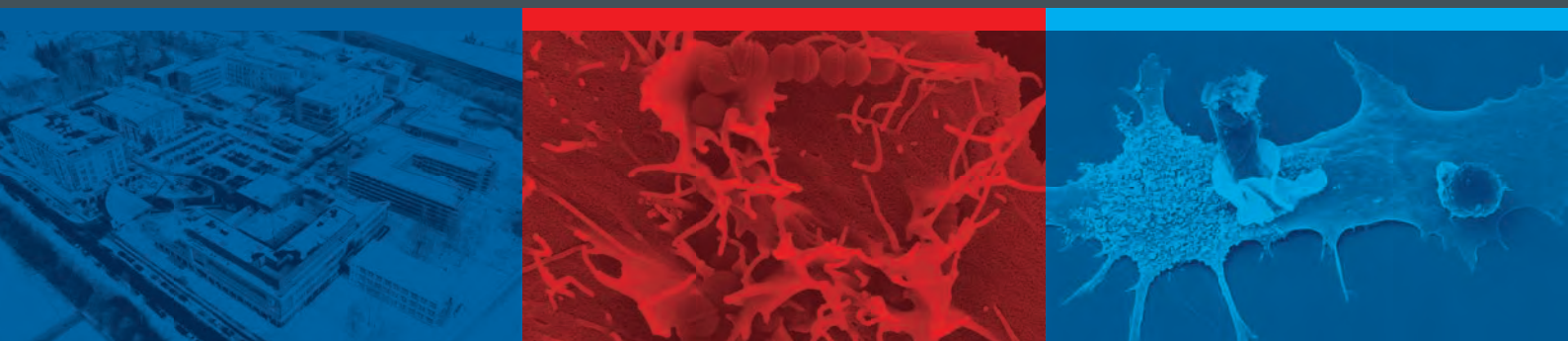

Focus and Highlights

- 18 Research review Topic 1: *Yersinia* Virulence: Mechanisms of Microbial Temperature Sensing
- 28 Research review Topic 2: Regulation of Immune Activation and Suppression: The Dual Role of NFκB Signalling
- 34 Research review Topic 3: New Options for Rational Biosynthetic Engineering of Novel Polyketide Drugs
- 40 Rational Genome Engineering – on the Generation of Cell and Mouse Models for Infection
- 48 Epidemiological Research at the HZI – a new Important Tool
- 54 The HZI Providing Efforts on the Balance between Career and Family
- 60 Research Climate and Atmosphere at HZI
- 62 On the living conditions in the Braunschweig-Wolfenbüttel Region
- 64 Highlights 2012/2013
- 72 New Junior Research Groups
- 74 Structural Biology of Autophagy in Infection and Disease
- 80 Actinobacteria Biosynthetic Potential
- 84 Molecular Mechanisms of *Salmonella* Virulence and Type-III Secretion
- 86 Interplay of Inflammasomes, Commensals and Pathogens at Mucosal Interfaces
- 88 Chronic *Pseudomonas aeruginosa* Infections: Towards Anti-Adhesion Therapeutics for Biofilm Dispersal and Inhibition

Bacterial and Viral Pathogens

- 92 Topic: Bacterial and Viral Pathogens
- 96 Streptococci and Pneumococci
- 98 Function and Regulation of *Yersinia* Virulence Factors
- 100 A Cellular Lipase Helps Flaviviruses to Release Infectious Viral Progeny
- 102 Mechanisms of Host Defense Against Infection with *Staphylococcus aureus*
- 104 Metabolic Diversity
- 106 Biofilm Communities
- 108 Pathogenesis of Chronic *Pseudomonas aeruginosa* Infections
- 110 Microbial Communications
- 112 Structural Analysis of Virulence Factors
- 114 Structural Biology of Viral Persistence and Mammalian Prions
- 116 Structural and Mechanical Analysis of Functional Amyloids
- 118 Intracellular Trafficking, Survival and Persistence of Streptococci
- 120 Molecular Diagnostics of Microbial Pathogens
- 122 Analysis of Protein Networks Induced by Early Host-Pathogen Interactions
- 124 Bioinformatics and Statistics
- 126 Epidemiological Determinants for Infections in Human Populations
- 128 Regulation by RNAs and Proteins – Modulators in Bacterial Pathogens
- 130 A Proteomics Approach to Understand Host-Pathogen Interactions
- 132 Actin-based Motility of Parasites
- 134 Random and Targeted Genomic Integration of Viruses

Immune Response

- 138 Topic: Immune Response and Interventions
- 140 Vaccine Technologies
- 142 Mycobacterial Phagosomes & Immunity
- 144 Systems Genetics of Infection & Immunity
- 146 Modulation of Innate Immunity by Herpesviruses
- 148 Mucosal Immunity and Inflammation
- 150 Development and Functional Properties of Foxp3⁺ Regulatory T Cells
- 152 Cell Death Mechanisms in Immunity
- 154 Immune Effectors: Molecules, Cells and Mechanisms
- 156 Interferons in Viral Defense & Immunity
- 158 Direct *In Vivo* RNAi Screening for Therapeutic Targets
- 160 Systems Immunology
- 162 Effect of Chronic Infections on the Adaptive Immune System
- 164 Innate and Adaptive Immunity
- 166 Autophagy in Infection and Disease
- 168 Cellular Models
- 170 Molecular Epidemiology of Acute Respiratory Infections
- 172 Neuroinflammation and -regeneration: A Highly Complex Interdependency
- 174 Inflammation and Regeneration
- 176 Therapeutic Cellular Vaccines
- 178 Clinical Outcomes of Infectious Diseases



Anti-Infectives

- 182 Topic: Anti-Infectives
- 186 Biodiversity Mining, Secondary Metabolomics and Applied Microbiology of Novel Anti-Infective Natural Products
- 188 Development of Anti-Infectives with Novel Modes of Action
- 190 Medicinal Chemistry of Natural Products
- 192 Metabolomics and Synthetic Biotechnology Tools for Novel and Optimised Natural Products
- 194 Chemical Biology of Infectious Diseases
- 196 Identification of Molecular Targets of Anti-Infectives
- 198 Actinobacteria Biosynthetic Potential: Bridging in *Silico* and *in Vivo*
- 200 Nanotechnology and Cell Culture Models of Biological Barriers
- 202 Microbial Strain Collection

Platforms

- 206 Central Animal Facility
- 208 Helmholtz Protein Sample Production Facility
- 210 Genome Analytics
- 212 Peptide Synthesis
- 214 Mouse-Pathology
- 216 Transgenic Mice
- 218 Flow Cytometry and Cell Sorting
- 220 Central Facility for Microscopy

224 HIPS

The Helmholtz-Institute for Pharmaceutical Research Saarland

236 Twincore

Centre for Experimental and Clinical Infection Research GmbH

244 DZIF

The German Centre for Infection Research
Deutsches Zentrum für Infektionsforschung

252 Facts & Figures

254 Organisation Chart

256 Imprint

The Helmholtz Centre for Infection Research

Infectious diseases are one of the main causes of human death worldwide. According to a study published by the medical journal Lancet in 2012, every fifth fatality can be directly ascribed to an infection. Furthermore, bacteria, viruses and other pathogens – as well as inflammatory processes triggered by them – play a key role in the development of non-communicable diseases like cancer and neurodegenerative disorders. Multidrug-resistant pathogens pose a particular danger to chronically ill persons and the elderly, leading to an increasing global public health problem. New concepts and approaches to counter this enormous challenge are urgently needed.

At the HZI research campus in Braunschweig, more than 800 employees and about 100 visiting scientists from over 40 countries are working jointly to find solutions for the prevention and therapy of infectious diseases. In addition to the main campus, we have joined forces with the Hannover Medical School to found TWINCORE, a translational research centre in Hannover devoted to forge a closer link between basic and clinical research. Furthermore, the Helmholtz Institute for Pharmaceutical Research Saarland (HIPS) in Saarbrücken has been established as daughter institute of the HZI in 2009.

The development of new diagnostic approaches, vaccines or antibiotics critically depends on a proper understanding of the mechanisms underlying infectious diseases and their propagation in the host. Experts from various scientific disciplines work together under one roof pursuing different approaches to increase our knowledge about crucial mechanisms of infection, host immunity and the effects of potential drug candidates.

Microbiologists, for example, investigate how bacteria and viruses manage to enter our bodies, how bacteria communicate and how exactly they make us ill. Geneticists study our genetic make-up looking for reasons why, for example, one person falls ill with flu while his or her neighbour does not. Immunologists strive to unravel how the host immune system reacts to intruders and eliminates them; structural biologists elucidate the three-dimensional structures of key molecules describing the atomic details of all their interactions.



Based on the findings of their colleagues from other disciplines, chemists develop new compounds which can be utilised to combat pathogens at specific target locations. Epidemiologists, on the other hand, focus on the spread of pathogens within a whole population – or, at least, subgroups within the population, including individuals who are not even infected. Vaccine researchers pursue the most effective way to combat germs: They work on new strategies to prevent pathogens from making us ill in the first place. Pharmacologists, particularly at the HIPS in Saarbrücken, deal with a crucial step towards the application of novel anti-infectives: They optimize and refine promising molecules for medical and clinical purposes. Therefore, they are looking for methods to transport such molecules across biological barriers to the target location more efficiently and optimize their chemical formulation.

But translational research at the HZI does not stop there: At the TWINCORE in Hannover, physicians and basic scientists work side by side, jointly drawing up solutions for urgent clinical problems.

All of these various approaches serve to achieve one common goal, and we firmly believe that it is the combination of these different efforts that will eventually lead to success. Thus, step by step, progress is being made towards resolving an old - and yet current - problem: protecting people against infectious diseases.



Prof. Dr. Dirk Heinz

Scientific Director

Foreword

Only a bit more than a decade after having changed its focus, the Helmholtz Centre for Infection Research (HZI) is already acknowledged as a major player in the national infection research community and on its way to becoming an internationally leading institute in the field.

This development has been leveraged by the recruitment of a good mixture of younger talents and more experienced staff, steady investment in world-class infrastructure and modern research facilities, excellent regional, national and international partnerships with universities, clinics and research institutions, as well as the continuous refinement of HZI's research strategy in the course of the past two periods of programme-oriented funding (POF) by the Helmholtz Association of German Research Centers.

With its new programme "Infection Research", which outlines the centre's research aims for the next five years and has recently received a very positive assessment by an international review panel, the research strategy of the HZI has been rationalized along three tightly linked topics:

In Topic 1, "Bacterial and Viral Pathogens", researchers investigate clinically relevant infectious diseases caused by bacteria and viruses, striving to unravel risk factors for infections, to elucidate the molecular basis of virulence and to identify and characterize potential biomarkers and targets for novel diagnostics and anti-infective strategies.

Topic 2, "Immune Response and Interventions", is dedicated towards a better understanding of the host response against infections. The elucidation of innate and adaptive immune responses to infection as well as transmission and clearance mechanisms are of central interest to this topic. In addition, sophisticated strategies of pathogens to evade detection by the host immune system, or to even subvert host factors for their propagation, are investigated. Ultimately, the knowledge gained will form the basis for the development of new immune system based strategies for prevention and therapy of infectious diseases.

Topic 3, “Anti-Infectives”, addresses the continuing potential of natural compounds as a unique source for novel anti-infectives. Chemists and pharmacists, in close cooperation with microbiologists and virologists, apply extensive screening approaches, microbial genome mining and synthetic biotechnology to identify and further optimize natural compounds with antibacterial and antiviral activities targeting *e.g.* adhesion, invasion and communication of pathogens and to develop innovative carrier systems for their targeted delivery.

The rapid translation of knowledge gained from HZI’s basic research portfolio into the clinical application constitutes a central element of the new research programme. This ambitious goal has been reinforced by the recent establishment of two joint institutes with universities: TWINCORE Centre for Experimental and Clinical Infection Research in Hannover, jointly operated with Hannover Medical School (MHH), and the Helmholtz Institute for Pharmaceutical Research Saarland (HIPS) in Saarbrücken on the campus of Saarland University, where HZI is also closely connected to the new and developing Centre for Pharmaceutical Research. Being embedded in regional and national research networks such as the Translational Alliance in Lower Saxony (TRAIN) and the recently established German Centre for Infection Research (DZIF), HZI shares scientific expertise and excellent infrastructures with numerous partners in the field of translational infection research.

HZI is also one of the partners of the Clinical Research Centre (CRC) Hannover, together with MHH and Fraunhofer ITEM, starting operation in 2014. CRC will offer the unique opportunity to run clinical studies in an academic setting.

TU Braunschweig continues to be our most important local academic partner both in educational and research aspects. Besides jointly setting up a Master’s course in infection research, the new Braunschweig Integrated Centre for Systems Biology (BRICS) on the campus of TU Braunschweig will foster systems biology and bioinformatics to study bacterial infections. With our university partners Otto von Guericke University (OVGU) Magdeburg and University of Veterinary Medicine Hannover (TiHo), the main focus of cooperation is on systems immunology/clinical infectiology and zoonotic infections, respectively. HZI’s active participation in the Centre for Structural Systems Biology (CSSB) on the campus of the German Electron Synchrotron DESY in Hamburg will open up whole new opportunities for structural infection biology at the systemic level.

The research campuses of HZI and HIPS are also constantly being further developed in accordance with our research strategy: In Braunschweig, the new S3 building will allow safe research on the most dangerous pathogens, and the capacity of our infection research building D has been extended by a modern



The TWINCORE facilities in Hannover
TWINCORE



The Campus of the University of Saarland, Saarbrücken, where also HIPS is located. A new facility for HIPS has started to be set up from 21 August 2013 University of Saarland



The Campus of DESY, where the CSSB is doing research. A new facility for CSSB will be set up in the near future DESY

office building. A new building for administration, library and canteen will enhance service and communication on the Braunschweig campus. The planned Centre for Drug Research and Functional Genomics (DRFG) in Braunschweig, together with the local Leibniz institute DSMZ and TU Braunschweig, and the new HIPS building in Saarbrücken will facilitate the pursuit of innovative drug research, which is further supported by close cooperation with chemists at Leibniz University in Hannover.

While state-of-the-art infrastructures are a prerequisite for internationally competitive research, creative and dedicated scientists are even more important for the success of a centre. We are pleased that the HZI has been able to recruit excellent researchers at all career levels in the past three years, extending and complementing the scientific portfolio of the centre especially in the areas of bacterial and viral pathogenesis, microbial communities, epidemiology, neuro-inflammation, structural biology and natural compound research.

This research report not only gives an overview of the newest exciting developments of our centre but also summarizes the most recent achievements of our researchers and cooperation partners. We strongly believe that it will transport the idea of a vibrant international research environment making the centre an attractive place to work.

Infectious diseases continue to pose a severe threat to human health worldwide. Even in well developed countries like Germany, newly emerging and multidrug-resistant pathogens constitute serious public health problems that need to be addressed with utmost urgency. We are confident that, thanks to the joint efforts of our strongly motivated employees in research and administration, the fruitful interactions with our partners, as well as the continuing support from the funding authorities and our scientific advisory board, HZI is well prepared to take on these important challenges. We are looking forward to the coming years of exciting and successful infection research.



Prof. Dr. Dirk Heinz

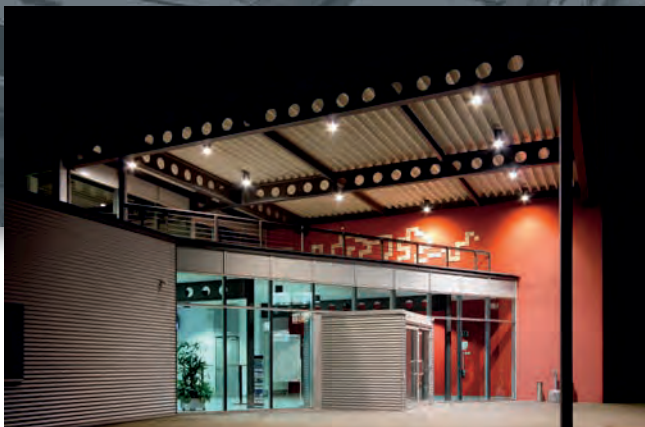

FORUM - where the HZI organizes meetings - at night HZI/Bischof



Building bridges! From basic research to the patient HZI/Bischof



The Christmas Market is one of the most beautiful markets with a longstanding tradition in Braunschweig HZI/Murthy



A city that reflects its values - the Braunschweiger lion reflected in the windows of Burg Dankward HZI/Murthy



Communion at the HZI at a special level HZI/Bischof



Where microscopic details matter - Colleague looks at cells through microscope HZI/Murthy



Pipetting at the work place in the laboratory HZI/Lübke



The flags fly high - Helmholtz flags (blue and white) in front of Forum HZI/Murthy

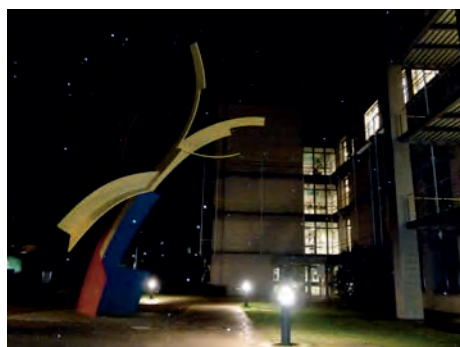

A sculpture of arts during snow fall HZI/Kügler-Walkemeyer



Programme Speaker

Prof. Dr. Ulrich Kalinke

Executive Director of TWINCORE

Research Group: Experimental Infection
Research (EXPI)

ulrich.kalinke@twincore.de

Programme Infection Research

Causes of Deaths Worldwide	Total=100%
Cardiovascular diseases	29,34%
Infectious diseases	23,04%
Cancer	12,49%
Respiratory diseases	6,49%
Unintentional injuries	6,23%
Perinatal conditions	4,23%
Digestive diseases	3,45%
Intentional injuries	2,84%
Neuropsychiatric disorders	1,95%
Diabetes mellitus	1,73%
Dis. genitourinary system	1,49%
Nutritional deficiencies	0,85%
Others	5,87%

WHO 2004, estimates for 2002

Infectious diseases

In recent human history, the overall infectious disease burden has significantly been reduced by enhancing hygienic conditions and improving the overall nutritional status. Furthermore, preventive vaccines and antimicrobial drugs additionally contributed to control infectious diseases. Nevertheless, infections continue to be the second-most frequent cause of mortality worldwide and also in highly developed countries they constitute a major health threat. Increasing travel activities and global trading enhances the risk for rapid worldwide spread of infectious agents. Newly emerging pathogens such as severe acute respiratory syndrome coronavirus (SARS), Middle East respiratory syndrome coronavirus (MERS) and swine as well as bird influenza may invade the human population. The 2011 epidemic of a Shiga Toxin-producing *Escherichia coli* (STEC) in Northern Germany, which caused more than 50 deaths, illustrates that even in highly developed countries outbreaks can cause severe public health emergencies. Furthermore, chronic viral infections such as human immunodeficiency virus (HIV) and hepatitis C virus (HCV) infections are associated with significant morbidity worldwide.

The antibiotic crisis

Effective treatment of infectious diseases by anti-infectives is severely hampered by the appearance of resistant pathogens. This fact is further exacerbated by the inappropriate use of antibiotics both in humans and animal livestock. In addition, the ability of bacterial pathogens to form biofilm communities reduces the efficacy of antibiotics by physically blocking the penetration of drugs. The “antibiotic crisis”, characterised by therapy failures and rising treatment costs, is aggravated by the constantly decreasing supply with new antibiotics with only a handful of new substance class candidates currently being developed by the pharmaceutical industry. For antiviral therapy the situation is even worse as only a very limited number of virus infections currently can be treated by approved drugs.

New vaccines needed

Vaccines have been proven very efficacious in preventing or treating infectious diseases. Although vaccines exist against many pathogens there is an urgent need for new vaccines against several wide-spread pathogens (such as HCV, herpes virus, dengue virus, malaria and HIV), newly emerging pathogens and variants of known pathogens (such as tuberculosis and influenza). Furthermore, vaccines with increased efficacy are needed in order to protect non-responders

and to establish facilitated vaccination regimens. Because on the population level the true effectiveness of several vaccines is below their pharmaceutical potential, for instance due to replacement phenomena, selection of even more virulent strains can occur favoring the spread of antigenic strains not covered by existing vaccines. Therefore, it is necessary to better understand pathogen immune evasion mechanisms and the host immune response. This will constitute the basis to improve existing vaccines and to develop new vaccination strategies.

The programme INFECTION RESEARCH

Considering the enormous challenges arising from infectious diseases, it is mandatory to gain an improved understanding of virulence mechanisms as the basis for discovery of new targets and drugs for preventive and therapeutic interventions. Pathogen-host interactions need to be investigated for the development of novel specific and broad-spectrum anti-infectives. For anti-virals, the ultimate goal is to identify new compounds that interfere with viral functions and/or host components crucial for the viral life-cycle. Fundamental mechanisms of pathogenesis of selected clinically relevant bacterial and viral infections are being explored in animal models as well as with patient specimen. One focus is laid on deciphering mechanisms of pathogen entry and replication as well as microbial communication in biofilms. Furthermore, relevant mechanisms of the pathogen-specific host response are being dissected. Such data will be instrumental in establishing new preventive and therapeutic strategies. Discovery of new targets on the level of the pathogen as well as the host will be followed. A complete natural product identification and modification pipeline is being exploited to screen natural product libraries for new candidates with anti-infective properties. Special emphasis is being laid on new classes of anti-infectives and new modes of action. Finally, new targets, strategies and candidates will be explored for their applicability in clinical practice. For this purpose a comprehensive translation pipeline comprising central elements of preclinical testing and the infrastructure to perform early clinical trials have been established.

Infections may also cause or influence several non-communicable common diseases such as cancer, neurodegenerative diseases, metabolic and immune disorders and cardiovascular diseases. Confirmed examples for infection induced cancer include *Helicobacter pylori*, human papilloma virus, HIV and hepatitis B virus and HCV, whereas metabolic disease may be associated with enterovirus infection, and cardiovascular diseases are induced by infection with certain streptococci strains. Already in the past within the programme INFECTION RESEARCH important knowledge was gained of how chronic HCV infection induces gastric cancer and how different streptococci strains induce cardiovascular disease. Interestingly, non-pathogenic commensals may also affect the balance between health and disease. It will be a matter of future research to study the exact correlations in greater detail. The analysis of the impact of infections on non-communicable diseases will benefit from the recently initiated National Cohort Study as well as from close collaborations with clinical partners and other Helmholtz health research centres.

Development of new bioactive natural compounds

Natural compound research has a long standing track record at HZI resulting in the development of new pharmaceuticals such as epothilone which was approved in 2007 as an anticancer agent (IxempraR, Bristol-Myers Squibb – BMS) and argyrin and disorazol which are approaching phase I clinical trials with anti-cancer applications. During the last few years this expertise has been intensively applied to identify several new candidates inhibiting growth of Gram-positive as well as Gram-negative bacteria and viruses. These candidates are currently being further optimized and it is anticipated that within the next 5 years at least some of the most promising candidates will be moved towards early clinical testing. These examples illustrate that the unique combination of expertise within the programme INFECTION RESEARCH enables research in the fields of natural products, chemical biology and pharmaceutical sciences under one roof.

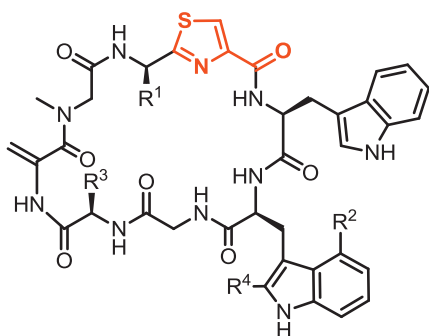

The Argyrins HZI

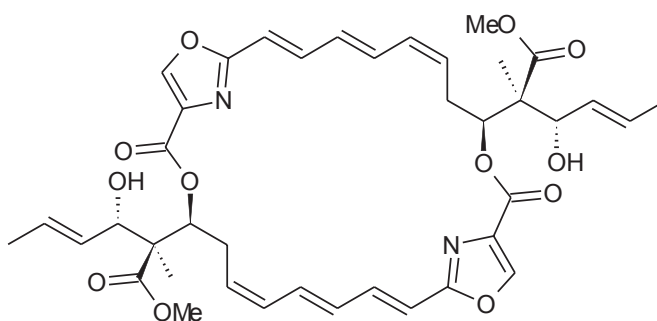

Structure of Disorazol Z HZI

Towards individualized infection medicine

Infection research at HZI is motivated by clinical needs in the field of infectious diseases. Pathogens currently under investigation include chronic (HCV and herpes virus) and acute (influenza virus) viral pathogens as well as Gram-positive (streptococci, MRSA, *Clostridium difficile*) and Gram-negative (*Pseudomonades*, *Yersinia*) bacterial pathogens, with a special focus on microbial communities (biofilms) that render pathogens refractory to antibiotic treatment or to the host's immune attack. Based on epidemiologically validated criteria the researched pathogen spectrum is continuously being adjusted. By building multidisciplinary research teams knowledge arising from basic research is channeled into clinical practice, while medical observations and challenges are communicated back to basic researchers. Close collaborations between physician scientists and basic researchers additionally facilitate access to patient specimen and allows conjointly planning of translational research activities. Research is performed to develop novel strategies for prevention, diagnosis and therapy of infectious diseases. In addition to pre-clinical research, patient oriented research and early clinical studies will be performed in a new clinical research centre which is currently being established by the partners HZI, Hannover Medical School and Fraunhofer ITEM and which will be opened in 2014.

This interdisciplinary network is crucial to drive research towards the development of tailored and individualized patient management concepts in infection medicine. Already now the therapy of some chronic virus infections is accompanied by the testing of critical pathogen and host associated biomarkers (e.g. HCV genotype and host single nucleotide polymorphisms within the type III IFN locus). Research activities at HZI not only focus on single patients and patient cohorts but also on population aspects. Current research activities involve patient specimen for the identification of new biomarkers that predict the course of infectious disease and/or treatment response. In the future these findings will be applied to advance the development of novel diagnostics and ultimately to move towards personalized infection medicine.

INFECTION RESEARCH, a concerted approach between several specialized partners

Recent technological breakthroughs in molecular biology, genetics, biochemistry, cell biology and immunology rapidly widen our knowledge on pathogenesis including pathogenicity and host defense mechanisms. The complex interplay between pathogens and their hosts is being addressed at all levels of complexity, ranging from the interaction of single molecules to the dynamics of an infection within populations. Additionally, individual risk factors are being addressed. The programme INFECTION RESEARCH builds on advanced approaches in biomedical basic research to significantly contribute to the development of novel strategies against infectious diseases. Thus, the programme follows a truly translational approach which is grounded on profound basic research activities.

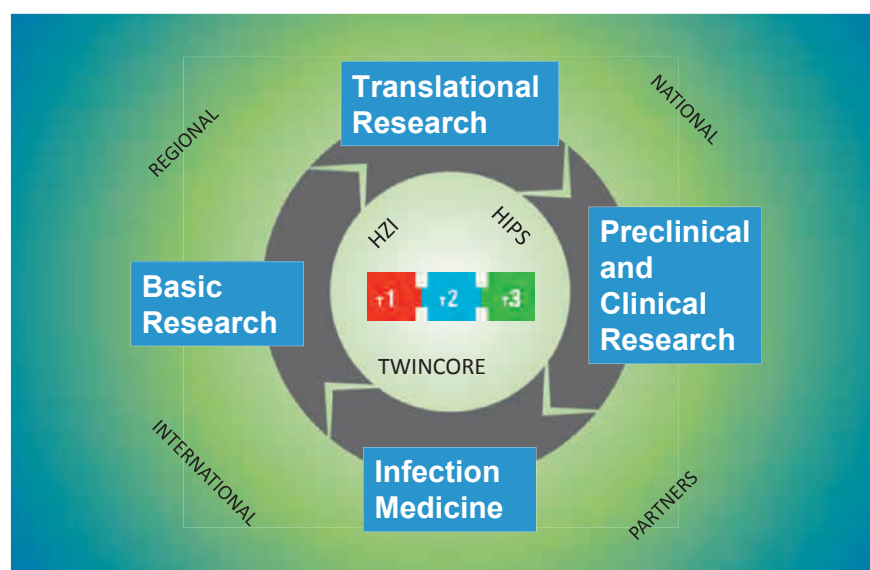

Programme „Infection Research“ – The Translational Cycle HZI



Considering the huge impact infections have on public health it is of crucial importance to better understand the complex interplay between pathogens and their hosts. The programme INFECTION RESEARCH builds on the scientific expertise and excellent infrastructures at three locations of the Helmholtz Centre for Infection Research (HZI), the main HZI campus in Braunschweig, the TWINCORE Centre for Experimental and Clinical Infection Research in Hannover, a joint venture between the Hannover Medical School and the HZI, and the Helmholtz-Institute for Pharmaceutical Research Saarland (HIPS) in Saarbrücken. Additionally, the HZI integrates strategic alliances on the national as well as the international level into the programme. Together with local universities (Hannover Medical School, Technical University Braunschweig, Otto-von-Guericke-University Magdeburg, Leibniz University Hannover, University of Veterinary Medicine Hannover, Saarland University), non-university institutions (Fraunhofer ITEM, Leibniz-Institutes such as DSMZ, and others), governmental institutions (Robert-Koch-Institute), international partners (such as the University of Alberta in Edmonton, Canada, Institut Pasteur in Paris, France, Karolinska Institutet in Stockholm, Sweden, the Imperial College in London, and others) and finally the pharmaceutical industry different expertises are jointly developed.

Furthermore, HZI is a founding member of the German Centre for Infection Research (DZIF), a national network which fosters and strengthens translational infection research in Germany. Within DZIF's organizational structure, HZI has a prominent position as location of the administrative main office, the funding management and the product development unit. Within DZIF's research activities, HZI/HIPS particularly contribute their expertise in the field of drug research for the discovery and development of novel anti-infectives in the thematic translational unit (TTU) "Novel Anti-infectives" and the infrastructure unit "Natural Compound Library". In accordance, the DZIF's core facilities for fermentation, down-stream-processing and compound storage and distribution as well as for assay development and screening are to be established at the HZI in the years to come. Furthermore, HZI scientists play leading roles in the TTUs "Gastrointestinal Infections", "Hepatitis", "HIV" and "Infections of the Immunocompromized Host", and the HZI is actively involved in the establishment of a future bioinformatics centre at the Hannover-Braunschweig site.

Research activities within the programme INFECTION RESEARCH are organized within three topics that focus on (i) bacterial and viral pathogens, (ii) the host response to infections and (iii) the discovery of novel drug candidates.

Topic 1 “Bacterial and Viral Pathogens”

investigates risk factors for spread, infectivity and susceptibility to infections. It analyzes virulence mechanisms of bacterial and viral pathogens ultimately aiming at making these accessible for the development of innovative antimicrobial therapies. To study colonisation and maintenance of infection as well as immune evasion, research is performed with clinically relevant pathogens and corresponding model pathogens.

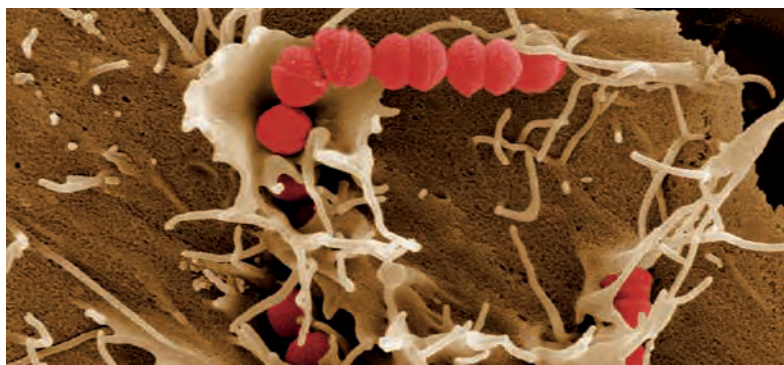

Streptococci (red) without SfbI protein (streptococcal fibronectin binding protein I) on the bacterial surface invade epithelial host cells by cytoskeletal rearrangements of actin, forming membrane ruffles. HZI/Rohde

Topic 2 “Immune Responses and Interventions”

explores the host response to pathogens. This is done by the analysis of pathogen transmission, immune modulation and clearance mechanisms of the host response, and by unraveling immune evasion mechanisms that are operative during the induction of innate and adaptive immune responses against infections. Based on this information new immune intervention strategies for prevention or treatment of infectious diseases will be developed.

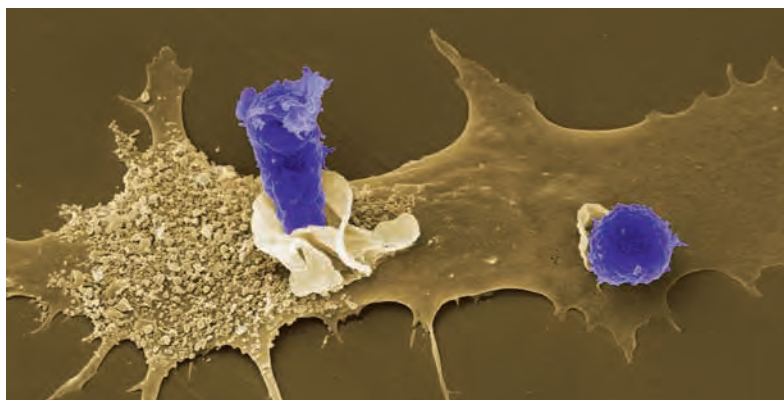

Cross-talk between two human T-cells (blue) and a human dendritic cell (yellow-brownish). After the first contact the dendritic cell responds with the formation of membranes engulfing partially the adherent T-cells. HZI/Rohde

Topic 3 “Anti-Infectives” covers the identification, characterisation, optimisation and delivery of known and new bioactive natural substances. To identify new bactericidal, bacteriostatic and antiviral active substance groups as well as innovative reagents that block host-pathogen interactions (anti-virulence strategies) the unique potential of microorganisms, such as myxobacteria and fungi, to synthesize a plethora of different natural substances is being explored.



Sorangium cellulosum, a gliding bacterium, showing trails and fruiting bodies (green) HZI/HIPS

Research within the topics is supported by several Enabling Technologies comprising structural biology, proteomics, high throughput genome and transcriptome analysis and platforms, such as the animal facility, BSL3 facility, and protein production facility.





Focus and Highlights

In this section, the report focuses on:

- Highlights of research results with regard to the R&D topics “Bacterial and Viral Pathogens”, “Immune Response and Interventions”, “Anti-Infectives”, and a contribution to the development of new methods.
- The importance of epidemiology, an exciting new research field at the HZI
- Factors ensuring an optimum employee working and living environment
- Introduction of the new junior research groups
- General highlights of the last two years including prizes, awards and conferences

Photos from left to right:

Prof. Emmanuelle Charpentier (middle), head of the Department “Regulation in Infection Biology”, was awarded the Alexander-von-Humboldt Professorship, left Prof. D. Heinz, right Prof. C. Baum (MHH/Kaiser) | The symbol of Braunschweig, the Lion, being reflected from windows of the Dankward castle, which was built during the Middle Ages (HZI/Murthi) | HZI started cooperation with the local primary school giving fourth graders the possibility to gain a first experience of what research is like (HZI/Grabowski)



Corresponding Author

Prof. Dr. Petra Dersch

Department of Molecular Infection Biology (MIBI)
petra.dersch@helmholtz-hzi.de

Co-Authors: Dr. Ann Kathrin Heroven,
Dr. Aaron Nuss, Dr. Fabio Pisano,
Department of Molecular Infection Biology (MIBI)

Yersinia Virulence: Mechanisms of Microbial Temperature Sensing

Gastrointestinal diseases are still a major health problem around the world. Rapid adaptation of enteric pathogens to often unknown environmental and animal reservoirs as well as the increasing number of multi-resistant variants of these pathogens hamper the control of diarrheal diseases and demand the development of new prevention and intervention strategies. In this context, identification of novel crucial virulence strategies that can serve as drug targets is of general interest. We focus on how expression of important pathogenicity factors of enteropathogenic *Yersinia* species and related pathogens is regulated in response to environmental cues and which control factors and mechanisms contribute to this process. The dissection of the complex regulatory networks of enteric pathogens and the comprehensive analysis of virulence gene expression during the course of the infection will allow us to identify crucial conserved global regulators of virulence which can be targeted by novel anti-virulence strategies.

Introduction

Gastrointestinal infections that cause diarrhea represent a huge public health problem in all parts of the world. In developed countries diarrheal diseases are under better control, but they are still counted among the most common types of infectious diseases, especially among children and the elderly. About 30,000 cases of gut-associated diseases caused by *Enterobacteriaceae* have been reported in Germany in 2012, mainly *Salmonella enterica*, *Escherichia coli* and enteropathogenic *Yersinia* species. They reside in environmental and animal reservoirs, are spread from person-to-person via the fecal-oral route and are frequently reported in food-borne outbreaks. In particular, microbial adaptation as well as changes in human demographics and food preferences/production, have led to the emergence and spreading of novel and known types of these pathogens.

Our primary focus is on *Y. pseudotuberculosis* and *Y. enterocolitica*. Once inside the human body, they trigger an impressive amount of different intestinal disorders ranging from diarrhea, enterocolitis, terminal ileitis to mesenteric lymphadenitis, that are collectively called yersiniosis. These diseases are typically self-limiting, although, sequelae such as long-lasting autoimmune disorders (reactive arthritis, erythema nodosum) or thyroiditis are also common.

Enteropathogenic *Yersiniae* are well adapted for a life in different locations outside and inside its mammalian hosts. They have a broad host spectrum and were frequently isolated from various environmental sources such as wild animals (e.g. boars, rodents and deer), livestock (e.g. sheep, pigs, cattle, goats and poultry), plants (carrots, salad), insects (flies), stored food (pork, venison) and faeces of animals. Pigs are the most important reservoir for human infections from which pathogenic *Y. enterocolitica* (in particular serotype O:3 and O:9 strains) can be routinely isolated (Carniel et al, 2006; Rosner et al, 2010).

After oral uptake by contaminated food or water, enteropathogenic *Yersiniae* initiate infections of its mammalian host by tight attachment to the mucosal surface in the intestine, which is frequently followed by rapid invasion and translocation through M-cells of the intestinal epithelium (early stage of infection). Migration through these cells leads to accumulation of the bacteria in the underlying lymphoid tissues (Peyer's patches) where they remain exclusively in an extracellular location, replicate rapidly outside cells and lead to the formation of microabscesses (later stage of infection) (Grutzkan et al, 1990; Simonet et al, 1990). Following Peyer's patches colonization, the bacteria disseminate into mesenteric lymph nodes, liver and spleen. Besides this uptake pathway, it has been demonstrated that after replication within the intestinal tract, the bacteria are also able to transfer through the intestinal epithelium and translocate to the organs by an alternative pathway independent of the Peyer's patches and the mesenteric lymph nodes (Fig. 1) (Barnes et al, 2006).

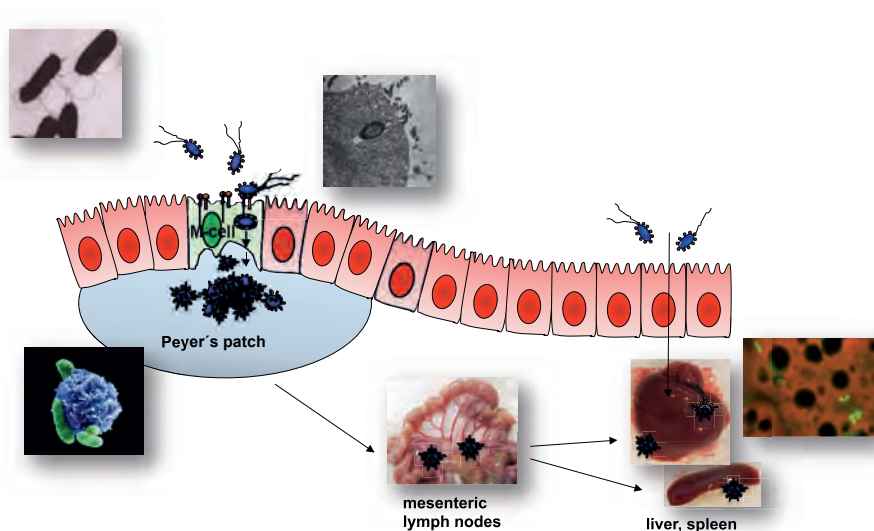

Fig. 1. Infection routes of enteropathogenic *Yersinia* species

After ingestion, the bacteria initiate infection of their host by tight attachment to the mucosal surface of the ileum, which is followed by rapid invasion into M-cells of the intestinal epithelium and their translocation into underlying lymphoid tissues (Peyer's patches) from which they disseminate to the mesenteric lymph nodes, liver and spleen. Figure: HZI

Efficient colonization of the ileum and invasion of the Peyer's patches is promoted by virulence factors (adhesins & invasins) that mediate the ability to contact and invade host cells and components that promote survival and multiplication within different niches of the host. Some of these virulence properties, including the cell invasion factor invasins, O-antigen of lipopolysaccharides

and flagellar motility, are only expressed under specific *in vitro* conditions (e.g. 20-25°C during stationary phase), which are typical for the free-living, stored food- or insect-associated lifestyle of the bacteria. This class of virulence factors is especially important for the survival in host environments that are encountered just before or during the very early stages of infection and seem to guarantee a fast and efficient penetration of the intestinal tracts shortly after ingestion. It is also possible that these gene products are utilized not only for the colonization of mammals, but also for other eukaryotic organisms (e.g. insects) in the environment. During later infectious stages in mammals, expression of these very early virulence genes is repressed. In contrast, synthesis of other pathogenicity factors is induced, which supports long-term survival of the bacteria in host tissues during later stages of the infection, e.g. the Ysc type III secretion system (T3SS), the antiphagocytic Yop effector proteins directed against host defences, and the *Yersinia* adhesin A (YadA) for colonization of deeper tissues and resistance against the complement system (Fig. 1). The mechanisms by which enteropathogenic *Yersinia* species manage to switch between environment and host, and how the bacteria alter and adjust the synthesis of virulence factors and virulence-associated traits during the different stages of the infection is largely unknown. For this reason, one major goal of our group is to gain a better understanding of the regulatory processes that control expression of virulence-associated factors throughout the infection. To fulfil this task we aim to unravel regulatory factors and mechanisms of virulence and characterize the regulatory network controlling the complex infection process of *Yersinia*. Furthermore, we address which, when and where certain virulence-associated factors are expressed during the infection and how they contribute to host colonization and the development of disease.

Global changes from the initiation of the infection to ongoing pathogenesis appear to be mediated through a highly complex network of regulatory pathways that modulate expression of virulence genes in response to multiple environmental cues. In particular, temperature and nutrient/ion content were found to control multiple transcriptional regulators implicated in this network on different levels and by very different molecular mechanisms.

1. Thermo-control of the early stage virulence genes by a protein thermometer

The transcriptional regulator RovA of *Y. pseudotuberculosis* activates the production of early stage virulence factors (e.g. the primary adhesion and invasion factor of *Yersinia* invasin), and several other virulence-linked traits, which contribute to an efficient colonization of gut-associated lymphatic tissues and allow faster progression of the infection. The RovA/SlyA family belongs to MarR-type transcription factors that are specialized in sensing their surrounding biosphere and control virulence and physiological processes involved in environmental and host-associated stress adaptation. Transcription of the *rovA* gene in *Y. pseudotuberculosis* is only induced at moderate temperatures and strongly autoregulated. Under inducing conditions (20-25°C), multiple RovA molecules bind

cooperatively to an extended AT-rich sequence (high affinity site) leading to activation of *rovA* expression (Fig. 2) (Heroven et al, 2004). Uncontrolled upregulation of *rovA* is prevented by binding of RovA to a low affinity site downstream of the promoter region when a certain RovA level has been reached upon autoactivation (threshold valve). Under non-inducing conditions (37°C), transcription of *rovA* is subject to silencing by the nucleoid-structuring protein H-NS, a dimeric, abundant global regulatory protein that controls transcription of many virulence genes in Gram-negative bacteria. DNA silencing is induced through simultaneous binding of multiple H-NS molecules to the high affinity-binding site of RovA (Fig. 3). However, a small amount of RovA remains readily available, and is used to turn on the autoregulatory circuit under inducing conditions by RovA-mediated derepression (antisilencing). This regulatory interplay also controls expression of *invA* (Fig. 2) (Heroven et al, 2004).

This raised our attention on the mechanisms that allow repression under non-inducing conditions and upregulation upon the appearance of the appropriate environmental signal. Detailed analysis of *rovA* expression revealed that temperature control of *rovA* is mediated by post-transcriptional mechanisms. RovA was shown to be a protein thermometer harboring an intrinsic thermosensor. A temperature upshift from moderate temperatures to 37°C induces reversible conformational changes in the RovA protein β (Herbst et al, 2009). Circular dichroism spectroscopy demonstrated a gradual loss of structured elements (α -helices) during a temperature increase between 25°C and 37°C. These alterations reduce the DNA-binding capacity of RovA and render the protein more susceptible to degradation by proteases, mainly the ATP-dependent Lon protease. This process makes RovA less capable to bind in a cooperative manner, and reduces its ability to activate its own synthesis (Herbst et al, 2009).

Functional and structural analysis of the RovA protein from *Y. pseudotuberculosis* (cooperation with the group of Prof. Dr. Dirk Heinz) revealed that RovA forms dimers and exhibits a central winged DNA-binding domain consisting of a helix-turn-helix (HTH) motif followed by two β -sheets (wings) (Fig. 3) (Quade et al, 2012). Helix α 4, which is part of the HTH motif, is deeply inserted into the major groove of the DNA and is responsible for most of the protein-DNA contacts. The β -stranded wing reaches into the next minor groove and interacts with several amino acids. However, most of these interactions are not base-specific and appear to be mainly formed through contacts with the phosphate backbone of the DNA in a low-affinity binding mode. Crystal structure analysis further revealed that helices α 1, α 5 and α 6 of both termini are important for dimerization. They form an extensive, well-packed, dimer interface, which helps to stabilize the for-

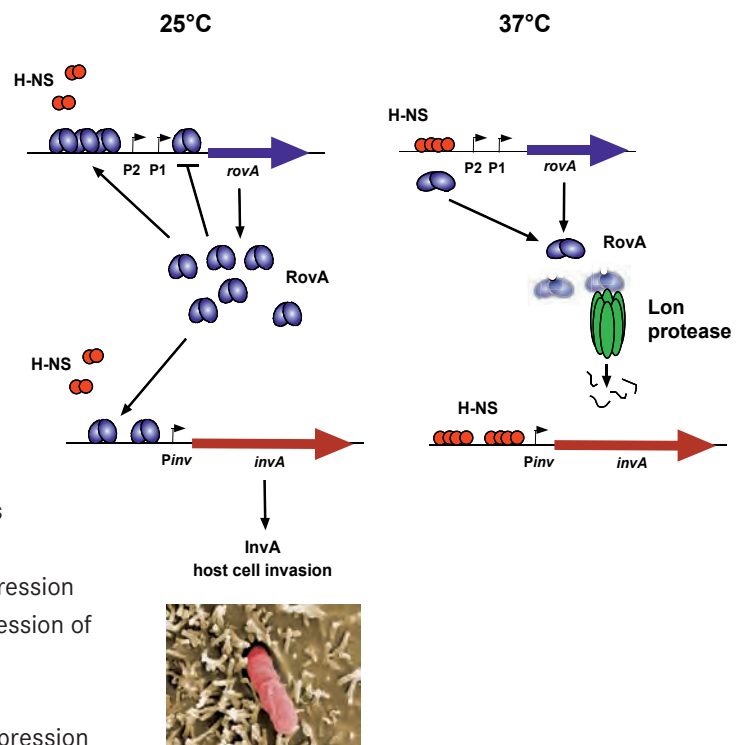
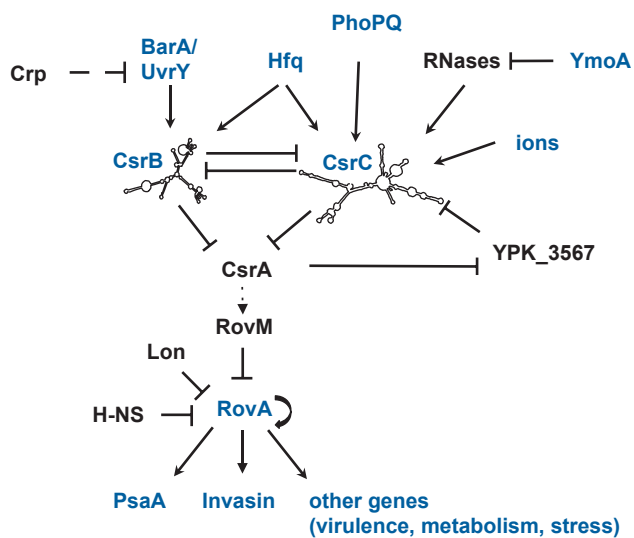

Fig. 2. Model of *rovA* thermoregulation. The global regulator RovA is activated at moderate temperatures (20°C-25°C) and binds to its target sequences in the *invA* and *rovA* promoter region thereby alleviating H-NS mediated repression. At higher temperatures (37°C), the protein undergoes a thermally induced conformational change that inactivates the protein, releases it from DNA and renders it more susceptible to degradation by the Lon protease. Figure: HZI

Fig. 3. Regulatory network of early stage virulence factors of *Y. pseudotuberculosis*. Environmental regulation of the early virulence gene regulator *RovA* is under the control of a complex regulatory cascade including transcriptional (e.g. *RovA*, *RovM*, *H-NS*) and post-transcriptional regulation systems (*Lon* protease, *Csr* system implicating the small regulatory RNAs *CsrB* and *CsrC*). The symbol \dashv illustrates negative and \rightarrow positive influence of the regulatory factor; dotted lines indicate indirect regulation; blue letters: regulators synthesized in the early infection stages and important for early virulence gene expression.

Figure: HZI



mation of dimers with properly positioned DNA-binding segments (Quade et al, 2012). We further demonstrated that a thermosensing loop in the dimerization domain and residues in the adjacent C-terminal helix promote thermo-induced loss of *RovA* activity. These determinants allow partial unfolding of the regulator upon an upshift to 37°C. This structural distortion is transmitted to the flexible DNA-binding domain of *RovA*, which allows the immediate release of *RovA* from its operator sites due to the low affinity-binding mode. We also showed that *SlyA*, a close homologue of *RovA* from *Salmonella* with a very similar structure, does not act as a thermosensor and remains active and stable at 37°C. Strikingly, changes in only three amino acids, reflecting evolutionary replacements in *SlyA*, result in a complete loss of the thermo-sensing properties of *RovA* and prevent degradation (Quade et al, 2012). In conclusion, only minor alterations can transform a thermotolerant regulator into a thermosensor that allows adjustment of virulence and fitness determinants to their thermal environment.

2. Nutrient-mediated control of the early stage virulence genes by regulatory RNAs

Besides temperature, *rovA* expression is also strongly influenced by the nutrient composition of the environment, e.g. it is only activated under high amino acid concentrations, but it is repressed in media with glucose as single carbon source. We found that regulation in response to nutrient availability is mediated through a regulatory cascade including a post-transcriptional regulatory system with significant homology to the carbon storage regulatory (*Csr*) system of *E. coli* and *S. typhimurium*. The *Csr*-system of *Y. pseudotuberculosis* consists of the regulatory RNAs *CsrB* and *CsrC*, which sequester the RNA-binding protein *CsrA*

that indirectly represses *rovA* activation and many other virulence-associated genes (Fig. 3) (Heroven et al, 2012,a). Both non-coding RNAs *CsrC* and *CsrB* have a complex secondary structure composed of multiple stem loops with GGA/RGGA sequences in the loop regions that are recognized and bound by *CsrA*. *CsrA* sequestration by the RNAs leads to inactivation and opposes influence of *CsrA* on its target mRNAs, which result in induction of *RovA* (Fig. 3) (Heroven et al, 2012,a). Our analysis further revealed that the *Csr* system forms a complex autoregulatory network in which both RNAs negatively affect each other and inhibit *CsrA* function, but they are themselves stabilized by *CsrA* (Heroven et al, 2008; Heroven et al, 2012,a).

In order to gain a deeper insight into the control of early stage virulence factors, we characterized expression of the *Csr* system in response to environmental parameters over the last four years and identified multiple signals and regulatory elements that affect the *Csr*-*RovA* regulatory cascade. We found that synthesis of the regulatory RNAs *CsrB* and *CsrC* is strongly dependent on the growth phase, ions and nutrient content of the medium. Transcription of *csrB* is generally very low under

laboratory growth conditions, but it can be induced by artificial activation of the two-component system BarA/UvrY and deletion of the gene encoding the cyclic AMP receptor protein (Crp). Crp was shown to repress CsrB transcription indirectly through UvrY (Fig. 3) (Heroven et al, 2012,b). The natural inducing conditions are not yet known. However, high induction of CsrB expression during the course of an infection in a mouse model indicates that certain host factors or metabolites sensed within the host trigger *csrB* transcription (Fig. 3). In contrast, the *csrC* gene is highly expressed in amino acid-rich media. However, readily metabolized carbon sources such as glucose have a negative influence on CsrC levels, and recent studies revealed that Crp is mainly implicated in nutrient-dependent expression of *csrC* (Heroven et al, 2012,b).

3. Thermo-control of the master virulence regulator LcrF by a thermo-labile regulator and an RNA thermosensor

In contrast to the early virulence network, synthesis of the most important later stage virulence factors (the adhesion YadA, and the type III secretion system (T3SS) and the translocated Yop effector proteins) is induced by the AraC-type transcriptional regulator LcrF (VirF in *Y. enterocolitica*). It was well known that LcrF in *Y. pseudotuberculosis* is only produced at 37°C, but the thermo-control mechanism was unclear. Over the last years we found that a hierarchy of a thermo-labile regulator and a unique intergenic RNA thermosensor induce LcrF synthesis at body temperature (Bohme et al, 2012).

a) Control of *lcrF* transcription by the thermo-sensitive modulator YmoA

The *lcrF* gene is expressed together with *yscW* (*virG*). Thermally regulated transcription of the *yscW-lcrF* operon is modest (3-4 fold) and was shown to be mediated by the thermo-sensitive modulator YmoA, which represses transcription from a single promoter located far upstream of the *yscW* gene. YmoA represses *lcrF* transcription directly through sequences located within the long 5'-UTR of *yscW* and this involves heterocomplex formation with the nucleoid-associated protein H-NS (Fig. 4). At 37°C, YmoA was shown to be subject to proteolysis by the Lon and Clp proteases leading to moderate upregulation of the *yscW-lcrF* transcript (Böhme et al, 2012).

b) Control of *LcrF* translation by a RNA thermometer

A second layer of temperature-control was found to complement the transcriptional response: a unique cis-acting RNA element located within the intergenic region of the *yscW-lcrF* transcript. RNA structure probing in cooperation with Prof. Dr. Franz Narberhaus (University Bochum) demonstrated that this region forms a secondary structure composed of two stemloops, which mediates post-transcriptional control in an RNA thermometer like manner. The first hairpin stabilizes the secondary structure, and the second hairpin sequesters the *lcrF* ribosomal binding site by a stretch of four consecutive uracils ("FourU") at 25°C. The second stemloop was more dynamic, and opening of its structure was favored at 37°C and permitted ribosome binding at host body temperature (Fig. 4) (Böhme et al, 2012).

As nothing was known about the function and role of the RNA thermometer in the regulation of *Yersinia* virulence factors during pathogenesis, we performed a detailed molecular analysis of the structure, dynamics and regulation of this postulated RNA thermometer. Deletion of the first or the second stem loop, and nucleotide substitutions that should destabilize (no base-pairing) or stabilize (perfect base-pairing) the putative thermoswitch (second stem loop) confirmed the structure and function of the RNA thermometer. Our study further provided first experimental evidence for the biological relevance of an RNA thermometer

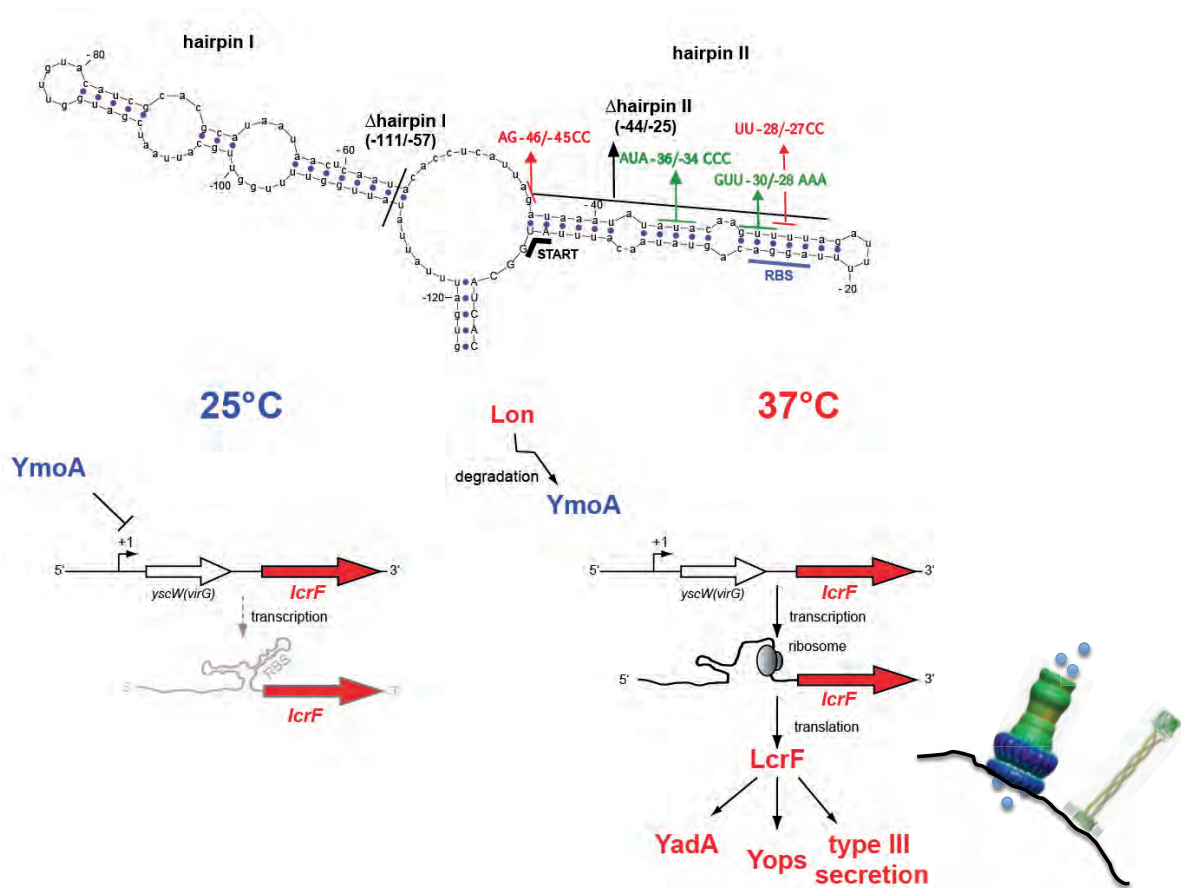

Fig. 4. Thermoregulation of the master virulence regulator LcrF

(A) Predicted secondary structure of the LcrF RNA thermometer. The blue dots represent base pairing. The start of the protein synthesis at the AUG start codon (START), the ribosome binding site (RBS) paired with the FourU motif, and tested deletion of hairpin I and II are indicated. Nucleotide exchanges leading to increased complementarity are marked in red, mutations impairing base pair formation are given in green.

(B) Model of thermoregulated synthesis of LcrF. At moderate growth temperature, the regulatory protein YmoA represses transcription. In addition, translation of the LcrF transcript is blocked through the formation of a two-stemloop structure. After a sudden temperature upshift upon host entry, proteases degrade YmoA. Furthermore, thermally-induced conformational changes of the RNA thermometer allow access of ribosomes and translation of the LcrF transcript, leading to LcrF synthesis and induction of all LcrF-dependent virulence genes of *Yersinia*. Figure: HZI

in an animal model. Following oral infection in mice, we found that two different *Y. pseudotuberculosis* patient isolates expressing a stabilized thermometer variant were strongly reduced in their ability to disseminate into the Peyer's patches, liver and spleen and fully lost their lethality (Böhme et al, 2012). Intriguingly, *Yersinia* strains with a destabilized version of the thermosensor were attenuated or exhibited a similar, but not higher mortality. This illustrates that the RNA thermometer is the decisive control element providing just the appropriate amounts of *LcrF* protein for optimal infection efficiency.

Future perspectives

Our studies revealed novel and important insights into the fine-tuned regulation of *Yersinia* virulence factors during the very early and later stages of the infection. However, many regulatory mechanisms of virulence-associated functions and critical control features by key regulators of the network are still unknown or not well understood. Their characterization, the investigation of their control networks and impact on virulence will be a major task of our future work.

In addition, a more comprehensive knowledge of how *Yersinia* adapts expression of virulence-associated traits, stress responses and metabolism to their actual habitats is critical for our understanding of pathogenesis and persistence in environmental and animal reservoirs, and could help to identify new prevention measures and intervention strategies. Recent establishment of transcriptional profiling by RNA-seq now allows us to compare the transcription profile of different *Y. pseudotuberculosis* patient isolates and key regulator mutant strains under different environmental conditions (e.g. temperature upshift, changes of oxygen, nutrient and ion concentrations), within host cells and during the course of an infection. The comparison of patient isolates and mutants which differ in their pathogenicity will give us valuable information about the core program and differences (i) of the expression profiles of potential virulence-associated genes, (ii) of their physiological state and (iii) in their transcriptional regulation networks which might contribute to the different disease outcome.

Our understanding of *Yersinia* virulence control has long neglected the influence of regulatory and sensory RNAs. However, several of such regulators have been recently found to facilitate host-microbe interactions and act as key regulators and switches between early and later stage virulence gene expression. In addition, many novel trans- and cis-acting regulatory RNA elements have been identified in our screening and preliminary expression and functional analysis identified them as potential parts of the control of virulence factors, bacterial stress responses, and metabolic adaptation processes with well-established roles in bacterial survival within the host. Regulatory RNA elements can operate at all levels of gene regulation, ranging from transcriptional initiation to protein activity. Future work will be directed to identify targets of RNA-based virulence gene regulation and study the versatile regulatory mechanisms employed by the RNA elements to control virulence in *Yersinia*.



Petra Dersch and her work group

Photos: Hallbauer & Fioretti

Recent discoveries of our group also include RNA-based control of many metabolic genes in *Yersinia*. This enables the pathogen to co-regulate metabolic and virulence processes and link nutritional status to virulence. As not only the special set of pathogenicity factors, but also the biological fitness defines the virulence potential of a pathogen, we intend to use RNA sequencing and other powerful high-throughput approaches (*e.g.* proteomics) to obtain a high-resolution picture of the regulatory networks that adjusts virulence factor expression and adapts the metabolism to the different *in vivo* habitats inside the host. The design of specific mutants and special knockout libraries will then be used to discover regulatory RNAs and key fitness regulators required for full virulence. Selected conserved regulators and small RNAs could potentially be exploited as novel drug targets.



Petra Dersch, born in 1965, is Head of the Department of Infection Biology at the Helmholtz Centre for Infection Research and full professor at the Technical University Braunschweig. She studied Biology at the Universities Ulm and Konstanz, and performed her PhD thesis work at the Max Planck-Institute for Terrestrial Microbiology in Marburg. After her graduation in 1995 she moved to Boston, USA, and worked as a postdoc in Ralph Isberg's lab at Tufts University. In 1989, she moved back to Germany and worked as a Research Assistant (C1) at the Free University in Berlin until 2002, and as a Junior Research Group Leader at the Robert Koch-Institute in Berlin until 2005. In 2005 she accepted an Assistant Professor position at the Technical University in Braunschweig and in 2008 she became Head of the Molecular Infection Biology Group at the Helmholtz Centre for Infection Research.



Ann Kathrin Heroven studied Biology at the Free University in Berlin and graduated in 2002 with a diploma in Biology. She started her doctoral thesis entitled "Function and environmentally-controlled regulation of the virulence regulator RovA in *Yersinia pseudotuberculosis*" at the Robert Koch Institute, Berlin, in 2003 in the Junior Research Group of Petra Dersch. After the move of the group in 2003 to Braunschweig, she finished her PhD thesis in 2007 at the Technical University of Braunschweig. Subsequently, Ann Kathrin Heroven started a postdoc first at the TU Braunschweig and later in 2009 at the Helmholtz Centre for Infection Research. She is now heading the subgroup "Virulence regulation in pathogenic *Yersinia* species" in the Department of "Molecular Infection Biology", Braunschweig.

Aaron Nuss studied Biology at the Justus-Liebig-University in Giessen and graduated in 2007 with a diploma in Biology. He then prepared his doctoral thesis entitled „The role of alternative sigma factors in the photooxidative stress response of *Rhodobacter sphaeroides*“ in the department of Prof. Gabriele Klug at the Justus-Liebig-University, Giessen. Subsequently Aaron Nuss started as a postdoc at the Helmholtz Centre for Infection Research, Braunschweig, in the group of Prof. Petra Dersch where he works hitherto on dual RNA sequencing of *Yersinia* and the host during the course of an infection.



Fabio Pisano was born in 1979 in Catanzaro, Italy. He graduated at the University of Bologna in Biotechnologies with major in Neurophysiology. In 2005, he joined the European Training Network IMDEMI (IMMuneDEficientMIce) for his PhD studies at the Helmholtz Centre for Infection Research in the group of Experimental Immunology under the supervision of Prof. Werner Müller. Since 2009 he works as a postdoc in the Molecular Infection Biology group headed by Prof. Petra Dersch, where he is responsible for *in vivo* infection models of Yersiniosis.



Publications

- Barnes, P. D., Bergman, M. A., Meccas, J., & Isberg, R. R. (2006) *Yersinia pseudotuberculosis* disseminates directly from a replicating bacterial pool in the intestine. *Journal of Experimental Medicine* **203**,1591-1601.
- Böhme, K., Steinmann, R., Kortmann, J., Seekircher, S., Heroven, A. K., Berger, E., Pisano, F., Thiermann, T., Wolf-Watz, H., Narberhaus, F., & Dersch, P. (2012) Concerted actions of a thermo-labile regulator and a unique intergenic RNA thermosensor control *Yersinia* virulence. *PLoS Pathogens* **8**, e1002518.
- Carniel, E., Autenrieth, A., Cornelis, G., Fukushima, H., & Guinet, F. (2002) *Y. enterocolitica* and *Y. pseudotuberculosis*. In: The Prokaryotes: An evolving electronic resource for the microbiological community (Dworkin, M., Falkow, S., Rosenberg, E., Scheifer, K. H., & Stackebrandt, E., eds.), Springer, New York, Vol. 3rd.
- Grutzkau, A., Hanski, C., Hahn, H., & Riecken, E. O. (1990) Involvement of M cells in the bacterial invasion of Peyer's patches: a common mechanism shared by *Yersinia enterocolitica* and other enteroinvasive bacteria. *Gut* **31**,1011-1015.
- Herbst, K., Bujara, M., Heroven, A. K., Opitz, W., Weichert, M., Zimmermann, A., & Dersch, P. (2009) Intrinsic thermal sensing controls proteolysis of *Yersinia* virulence regulator RovA. *PLoS Pathogens* **5**, e1000435.
- Heroven, A., Böhme, K., Rohde, M., & Dersch, P. (2008) A Csr-type regulatory system, including small non-coding RNAs, regulates the global virulence regulator RovA of *Yersinia pseudotuberculosis* through RovM. *Molecular Microbiology* **68**, 1179-1195.
- Heroven, A., Nagel, G., Tran, H. J., Parr, S., & Dersch, P. (2004) RovA is autoregulated and antagonizes H-NS-mediated silencing of invasin and *rovA* expression in *Yersinia pseudotuberculosis*. *Molecular Microbiology* **53**, 871-888.
- Heroven, A. K., Böhme, K., & Dersch, P. (2012,a) The Csr/Rsm system of *Yersinia* and related pathogens: A post-transcriptional strategy for managing virulence. *RNA Biology* **9**(4), 379-391.
- Heroven, A. K., Sest, M., Pisano, F., Scheb-Wetzels, M., Steinmann, R., Böhme, K., Klein, J., Munch, R., Schomburg, D., & Dersch, P. (2012,b) Crp induces switching of the CsrB and CsrC RNAs in *Yersinia pseudotuberculosis* and links nutritional status to virulence. *Frontiers in Cellular and Infection Microbiology* **2**, 158.
- Quade, N., Mendonca, C., Herbst, K., Heroven, A. K., Ritter, C., Heinz, D. W., & Dersch, P. (2012) Structural basis for intrinsic thermosensing by the master virulence regulator RovA of *Yersinia*. *Journal of Biological Chemistry* **287**, 35796-35803.
- Rosner, B. M., Stark, K., & Werber, D. (2010) Epidemiology of reported *Yersinia enterocolitica* infections in Germany, 2001-2008. *BMC public health* **10**:337.
- Simonet, M., Richard, S., & Berche, P. (1990) Electron microscopic evidence for *in vivo* extracellular localization of *Yersinia pseudotuberculosis* harboring the pYV plasmid. *Infection and Immunity* **58**, 841-845.



Authors

Prof. Dr. Ingo Schmitz

Research Group Systems-oriented Immunology and Inflammation Research (SIME)
isc09@helmholtz-hzi.de



Dr. Marc Schuster

Research Group Systems-oriented Immunology and Inflammation Research (SIME)
mas09@helmholtz-hzi.de

Regulation of Immune Activation and Suppression: The Dual Role of NF κ B Signalling

The immune system is constantly in contact with foreign microorganisms. These are incorporated via food and respiration or live in the gut, the oral cavity or on the skin. A commonly known example is the *E. coli* colonisation of the gut. In fact, the intestinal microbiota is instrumental for proper digestion of our food. The immune system's challenge is to tolerate these helpful microorganisms, but to fight harmful pathogens. To achieve this goal, the immune system is permanently exposed to inhibitory signals, thereby creating a threshold for its activation. Upon infection the number of pathogens massively increases. As a consequence, the immune system produces a multitude of signals forcing an immune response. The suppressive threshold is overridden. Thus, immune homeostasis is regulated via a balance of so called pro- and anti-inflammatory signals regulating activation and repression, respectively. Remarkably, both signals are regulated via the same signalling network, known as Nuclear Factor κ B (NF κ B). Understanding the pivotal role of NF κ B for the regulation of pro- and anti-inflammatory signals could help to develop therapies for the manipulation of immune homeostasis to treat diseases caused by a misbalance of suppressive to inductive signals.

Altering the balance of immune activation and suppression can cause chronic inflammatory diseases, autoimmunity or cancer

A well-balanced ratio of pro- to anti-inflammatory signals is essential for immune homeostasis. Over-suppression or over-activation can cause various terrible diseases. Pro-inflammatory signals are generated by a multitude of different effector cells, belonging to the innate and adaptive immune system. These comprise macrophages, dendritic cells and the T helper cell subsets TH1, TH2 and TH17. Impaired development or compromised function of these effector cells causes impaired clearance of infections with viruses, bacteria or parasites.

The key cell type for the maintenance of immune suppression represents the regulatory T (Treg) cells (Sakaguchi et al., 2006). Loss of Treg cells causes the immunodysregulation polyendocrinopathy enteropathy X-linked syndrome, or

IPEX for short, a mortal systemic autoimmune disease (Bennett et al., 2001; Bennett and Ochs, 2001). These children suffer from chronic inflammation of the gut, skin and develop certain signs of arthritis and diabetes. In IPEX patients the loss of Treg-mediated anti-inflammatory signals leads to the overwhelming activation of the immune system. The loss of suppressive signals is either the result of loss of Treg cells, or their impaired function. On the other hand, Treg cells accumulate in a variety of cancers in the vicinity of the tumour mass. This leads to a local increase of immune suppression. Thus, the tumour escapes immune recognition and clearance. So far, it is controversially discussed whether Treg cells are *de novo* induced at the tumour site or attracted to it. One approach to clinically exploit the suppressive capacity of Treg cells is to use them for increasing the acceptance of allo-transplants. Thus, pharmacologically targeting of immune-suppressive Treg bears curative potential.

Suppression and activation are regulated via NFκB signalling

Remarkably, both pro- and anti-inflammatory signals are regulated via NFκB signalling. Loss or impairment of NFκB activation dramatically decreases the production of several of the pro-inflammatory cytokines. For example, IL6 and IP10 are expressed upon IL1 or lipopolysaccharide treatment by innate immune cells like dendritic cells and macrophages. In cells of the adaptive immune system, expression of IL2, which drives the clonal expansion of activated T cells, is dramatically impaired when NFκB signalling is compromised.

On the other hand, NFκB signalling is necessary for the development of Treg cells via direct control of the transcription factor Forkhead box protein P3 (Foxp3) (Barnes et al., 2009; Ruan et al., 2009; Schuster et al., 2012). Its control over *Foxp3* expression is mediated via three conserved non-coding sequences (CNS1-3) (Zheng et al., 2010). So far, NFκB binding was reported to CNS2 and CNS3 and, in addition, to the *Foxp3* core promoter. Loss of NFκB-binding causes reduced transcriptional activity of these sites as analysed by luciferase-based reporter gene assays. Mice that are compromised in NFκB signalling, like CARMA1-, c-Rel- and, as we recently reported, IκB_{NS}-deficient mice consequently display a dramatic reduction of Treg cells.

Classical inhibitor proteins regulate NFκB activation

NFκB signalling is one of the most versatile of the known signalling networks as it is induced by a multitude of different stimuli and regulates an impressive variety of target genes (Hayden and Ghosh, 2012). The basic events of activation in the signalling cascade are well understood. NFκB is kept inactive by the inhibitors of NFκB signalling, the IκB proteins. The prototypical member of this protein class, IκBα, masks the nuclear localisation signal (NLS) of NFκB, thereby preventing its nuclear import and binding to the DNA. The common signalling event of all NFκB inducing stimuli is the activation of the IκB kinase complex (IKK-complex). This protein complex contains three subunits IKKα, IKKβ and IKKγ/NEMO. In classical signalling, the β-subunit of the IKK complex, once activated, phosphorylates IκBα. Phosphorylation of IκBα by the IKK com-

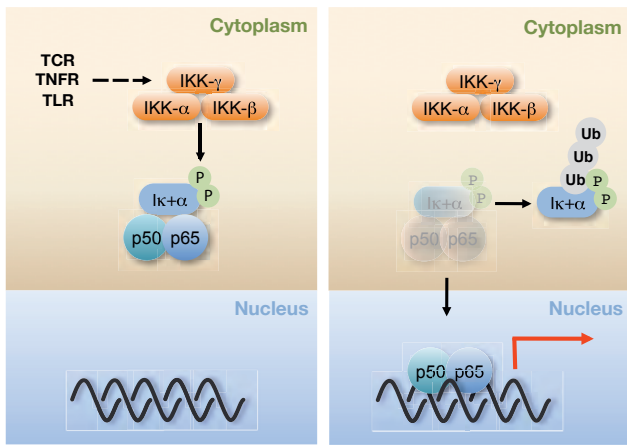

Fig. 1. NFκB signalling cascade. NFκB transcription factors are kept inactive in the cytoplasm via binding of IκBα. Upon activation of the IKK complex IκBα is phosphorylated (left). The phosphorylation causes its polyubiquitination, leading to its recruitment to the proteasome. After IκBα was degraded the free transcription factor can translocate into the nucleus and affect transcription (right). Figure: HZI

plex leads to ubiquitination and degradation of IκBα and the release of the NFκB transcription factor. Thus, the nuclear localisation signal of NFκB is accessible; the transcription factor translocates into the nucleus and binds to its respective target genes (Fig. 1).

NFκB type transcription factors are dimers consisting of members of the REL protein family p65, RelB, c-Rel, p52 or p50 (Fig. 2). Basically, all dimer combinations are possible, although certain combinations are preferentially generated. p65, c-Rel and RelB contain transactivation domains and thus, NFκB transcription factors containing at least one of these subunits induce gene transcription. On the other hand,

p50 and p52 lack such domains, whereby homo- or heterodimers of these proteins act as transcriptional repressors.

Atypical NFκB inhibitors modulate transcription in the nucleus

Next to classical IκB proteins, a subgroup of atypical IκB proteins exists. So far, four members of this protein class were identified: BCL3, IκB5, IκB_{NS} and IκBη (Fig. 3) (Bours et al., 1993; Fiorini et al., 2002; Yamauchi et al., 2010; Yamazaki et al., 2001). These proteins display remarkable functional differences to classical IκB proteins. For instance, they function after NFκB was initiated and modulate NFκB activity by binding to the transcription factor, which is already associated to the DNA, *i.e.* in the cell nucleus. The most remarkable difference to classical NFκB proteins is their capacity to enhance as well as repress gene transcription in a cell type and gene specific manner. For example, IκB_{NS} represses IL6, but activates IL2 (Kuwata et al., 2006; Touma et al., 2007). Thus, they are more transcriptional modulators than pure inhibitors like their classical relatives.

Fig. 2. NFκB transcription factor subunits: REL proteins. The common structural motif of all REL proteins is the REL-homology domain (green). This domain contains the region for dimerisation and nuclear localisation. p65, c-Rel and RelB contain transactivation domains (TAD) to enhance gene transcription. p52 and p50 originate from the precursor proteins p100 and p105 respectively. Both do not contain a TAD and, thus, can act as transcriptional repressors. Figure: HZI

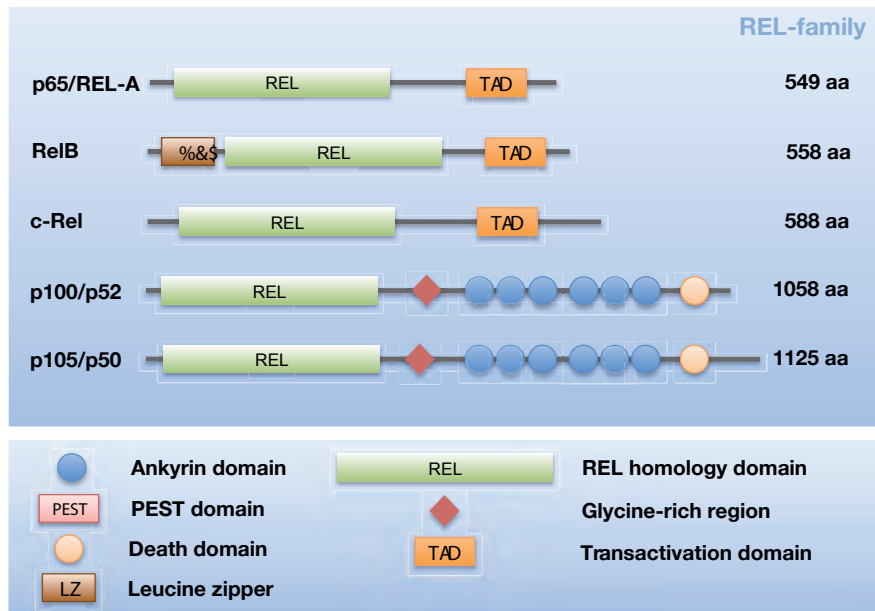

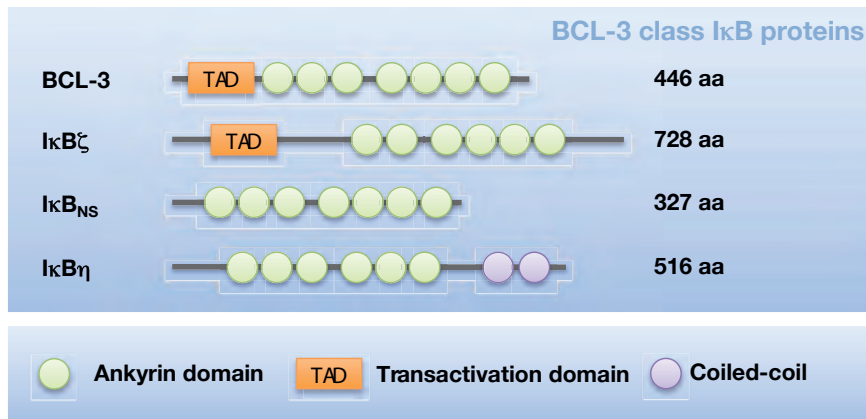

Fig. 3. Novel regulators of NF κ B signalling: Atypical I κ B proteins.

Atypical I κ B proteins share the common structural motif, the ankyrin domain, with classical I κ Bs. BCL3 as well as I κ B ζ contains transactivation domains, which can induce gene transcription. Figure: HZI

How these proteins can mediate these entirely opposing effects is not completely understood and requires further investigation. It also needs to be determined if any functional interactions between these proteins exist. So far, only single knock out studies were performed. Thus, it is not known, whether these proteins act cooperatively, sequentially or completely independently. It is part of the future work at the HZI to determine functional redundancies and interactions.

I κ B_{NS} is necessary for the production of pro-inflammatory signals

Initially, our research within the HZI focused on the role of the atypical NF κ B inhibitor I κ B_{NS}. It was first identified as a protein highly expressed in autoreactive T cells in the thymus undergoing negative selection (Fiorini et al., 2002). In this process, autoreactive T cells are deleted via apoptosis.

It was previously reported that the protein drives the expression of a variety of pro-inflammatory cytokines in adaptive immune cells. For example, full IL2 and IFN γ expression requires I κ B_{NS} in T cells. In B cells, loss of I κ B_{NS} causes impaired cell maturation in the marginal centres and reduced antibody production in plasma cells (Touma et al., 2011). Regarding innate immune cells it was reported that macrophages and dendritic cells produce more pro-inflammatory IL6 and IL12p40 when deficient for I κ B_{NS} (Hirotsani et al., 2005; Kuwata et al., 2006). We found that I κ B_{NS} is also strongly expressed in inflammatory T cells. These cells might be critical for the development of experimental autoimmune encephalomyelitis (EAE), a model system of multiple sclerosis disease. In a current project, we are addressing the role of I κ B_{NS} in TH17 cells and are going to determine its curative potential.

I κ B_{NS} is also necessary for the development of anti-inflammatory Treg cells

We recently published in the high impact journal "Immunity" that I κ B_{NS} is also necessary for the induction of Foxp3 and thereby for the development of Treg cells (Schuster et al., 2012). This result was highly surprising as reports for Foxp3-negative conventional T cells demonstrated that the protein is necessary for the production of IL2, which mediates T cell survival and clonal expansion during an immune response. Thus, on the one hand the protein is necessary for

an immune response via IL2 production, but on the other hand also for immune suppression via Foxp3 induction.

Loss of $\text{I}\kappa\text{B}_{\text{NS}}$ results in a dramatically impaired development of regulatory T cells. In thymus, spleen, peripheral and mesenteric lymph nodes we could detect barely half of the normal amount of Treg cells seen in wildtype mice. Remarkably, $\text{I}\kappa\text{B}_{\text{NS}}$ -deficiency does not affect the function of mature Treg cells. Their immune-suppressive capacity remains unaltered. Thus, $\text{I}\kappa\text{B}_{\text{NS}}$ function is basically only important for cell development but not for their maintenance and function.

NF κ B is most commonly known for its anti-apoptotic and pro-proliferative role. Thus, we analysed whether or not $\text{I}\kappa\text{B}_{\text{NS}}$ -deficiency alters Treg proliferation or apoptosis. However, no increase of apoptosis or reduction of proliferation was detected, which could have explained the observed phenotype. We found strong induction of the protein in developing thymic Treg cells, in the so-called Treg precursor cells. In these cells the protein is necessary for the induction of Foxp3 as the turnover into mature Treg cells is delayed in the absence of $\text{I}\kappa\text{B}_{\text{NS}}$. Most interestingly, the protein is only transiently expressed during Treg development since it is repressed after Foxp3 induction. This suppression is mediated directly via binding of Foxp3 to the $\text{I}\kappa\text{B}_{\text{NS}}$ promoter.

The physiological relevance of $\text{I}\kappa\text{B}_{\text{NS}}$ deficiency was demonstrated in a transfer colitis experiment. We could demonstrate that without $\text{I}\kappa\text{B}_{\text{NS}}$ less Treg cells develop in a chronically infected gut. As a consequence, the disease course is highly exacerbated as determined by weight loss, diarrhoea and histological sections of the gut.

The functional interaction of $\text{I}\kappa\text{B}_{\text{NS}}$ with other NF κ B components needs to be determined

Remarkably, $\text{I}\kappa\text{B}_{\text{NS}}$ -deficient mice display various similarities to other NF κ B-compromised mice. First of all, loss of the NF κ B subunit c-Rel causes a reduced Treg compartment to a similar extent by about fifty percent. Second, IL2 production and B cell development is impaired in both $\text{I}\kappa\text{B}_{\text{NS}}$ -deficient and c-Rel-deficient mice. We could also detect that both proteins interact with each other. In another research project we are going to determine whether $\text{I}\kappa\text{B}_{\text{NS}}$ and c-Rel act cooperatively or independently of each other during Treg development. Preliminary data revealed that $\text{I}\kappa\text{B}_{\text{NS}}$ and c-Rel double deficient mice barely develop any Treg cells and show a reduction of Treg cells by 90 to 95%. So, $\text{I}\kappa\text{B}_{\text{NS}}$ and c-Rel do act cooperatively during Treg development. The molecular explanation of this effect will be determined in our future research at the HZI.



Ingo Schmitz with his work group .

Photo: HZI/Hallbauer & Fioretti

Prof. Dr. Ingo Schmitz finished his diploma in biochemistry in 1996. He started his PhD in the lab of Prof. Peter Krammer at the DKFZ in Heidelberg, which he completed in 2000. From 2001 to 2003 he worked as a post-doc in the Dana-Farber Cancer Institute at the Harvard Medical School in Boston. After returning to Germany, he joined the Institute of Molecular Medicine of the University Hospital in Düsseldorf in the position of a group leader. 2008 he changed as a group leader to the Institute of Medical Microbiology and Hospital Hygiene. Since 2009 he is associate professor at the Institute of Immunology of the Medical Faculty of the Otto-von-Guericke-University of Magdeburg and the Helmholtz Centre for Infection Research in Braunschweig. He leads the research group of Systems-oriented immunology and inflammation research.



Dr. Marc Schuster studied biology and did his diploma in 2007. He started his PhD thesis in 2007 at the Institute of Molecular Medicine of the University Hospital in Düsseldorf in the group of Professor Ingo Schmitz. He continued his thesis at the Institute of Medical Microbiology and Hospital Hygiene and later at the Institute of Immunology of the Medical Faculty of the Otto-von-Guericke-University of Magdeburg and the Helmholtz Centre for Infection Research in Braunschweig. Since 2013 he is post-doc in the research group of Systems-oriented immunology and inflammation research.



Publications

Barnes, M.J., Krebs, P., Harris, N., Eidenschek, C., Gonzalez-Quintal, R., Arnold, C.N., Crozat, K., Sovath, S., Moresco, E.M., Theofilopoulos, A.N., *et al.* (2009) Commitment to the regulatory T cell lineage requires CARMA1 in the thymus but not in the periphery. *PLoS Biology* **7**, e51.

Bennett, C.L., Christie, J., Ramsdell, F., Brunkow, M.E., Ferguson, P.J., Whitesell, L., Kelly, T.E., Saulsbury, F.T., Chance, P.F., & Ochs, H.D. (2001) The immune dysregulation, polyendocrinopathy, enteropathy, X-linked syndrome (IPEX) is caused by mutations of FOXP3. *Nature Genetics* **27**, 20-21.

Bennett, C.L., & Ochs, H.D. (2001) IPEX is a unique X-linked syndrome characterized by immune dysfunction, polyendocrinopathy, enteropathy, and a variety of autoimmune phenomena. *Current Opinion in Pediatrics* **13**, 533-538.

Bours, V., Franzoso, G., Azarenko, V., Park, S., Kanno, T., Brown, K., & Siebenlist, U. (1993) The oncoprotein Bcl-3 directly transactivates through kappa B motifs via association with DNA-binding p50B homodimers. *Cell* **72**, 729-739.

Fiorini, E., Schmitz, I., Marissen, W.E., Osborn, S.L., Touma, M., Sasada, T., Reche, P.A., Tibaldi, E.V., Hussey, R.E., Kruisbeek, A.M., *et al.* (2002) Peptide-induced negative selection of thymocytes activates transcription of an NF-kappa B inhibitor. *Molecular Cell* **9**, 637-648.

Hayden, M.S., & Ghosh, S. (2012) NF-kappaB, the first quarter-century: remarkable progress and outstanding questions. *Genes & Development* **26**, 203-234.

Hirotsani, T., Lee, P.Y., Kuwata, H., Yamamoto, M., Matsumoto, M., Kawase, I., Akira, S., & Takeda, K. (2005) The nuclear IkappaB protein IkappaBNS selectively inhibits lipopolysaccharide-induced IL-6 production in macrophages of the colonic lamina propria. *Journal of Immunology* **174**, 3650-3657.

Kuwata, H., Matsumoto, M., Atarashi, K., Morishita, H., Hirotsani, T., Koga, R., & Takeda, K. (2006) IkappaBNS inhibits induction of a subset of Toll-like receptor-dependent genes and limits inflammation. *Immunity* **24**, 41-51.

Ruan, Q., Kameswaran, V., Tone, Y., Li, L., Liou, H.C., Greene, M.I., Tone, M., & Chen, Y.H. (2009) Development of Foxp3(+) regulatory T cells is driven by the c-Rel enhanceosome. *Immunity* **31**, 932-940.

Sakaguchi, S., Ono, M., Setoguchi, R., Yagi, H., Hori, S., Fehervari, Z., Shimizu, J., Takahashi, T., and Nomura, T. (2006) Foxp3+ CD25+ CD4+ natural regulatory T cells in dominant self-tolerance and autoimmune disease. *Immunity Reviews* **212**, 8-27.

Schuster, M., Glauben, R., Plaza-Sirvent, C., Schreiber, L., Annemann, M., Floess, S., Kuhl, A.A., Clayton, L.K., Sparwasser, T., Schulze-Osthoff, K., *et al.* (2012). IkappaB(NS) protein mediates regulatory T cell development via induction of the Foxp3 transcription factor. *Immunity* **37**, 998-1008.

Touma, M., Antonini, V., Kumar, M., Osborn, S.L., Bobenchik, A.M., Keskin, D.B., Connolly, J.E., Grusby, M.J., Reinherz, E.L., and Clayton, L.K. (2007). Functional role for IkappaBNS in T cell cytokine regulation as revealed by targeted gene disruption. *Journal of Immunology* **179**, 1681-1692.

Touma, M., Keskin, D.B., Shiroki, F., Saito, I., Koyasu, S., Reinherz, E.L., and Clayton, L.K. (2011). Impaired B cell development and function in the absence of IkappaBNS. *Journal of Immunology* **187**, 3942-3952.

Yamauchi, S., Ito, H., and Miyajima, A. (2010). IkappaBbeta, a nuclear IkappaB protein, positively regulates the NF-kappaB-mediated expression of proinflammatory cytokines. *Proceedings of the National Academy of Sciences USA* **107**, 11924-11929.

Yamazaki, S., Muta, T., and Takeshige, K. (2001). A novel IkappaB protein, IkappaB-zeta, induced by proinflammatory stimuli, negatively regulates nuclear factor-kappaB in the nuclei. *The Journal of Biological Chemistry* **276**, 27657-27662.

Zheng, Y., Josefowicz, S., Chaudhry, A., Peng, X.P., Forbush, K., and Rudensky, A.Y. (2010). Role of conserved non-coding DNA elements in the Foxp3 gene in regulatory T-cell fate. *Nature* **463**, 808-812.



Authors

Prof. Dr. Dirk Heinz

Department of Molecular Structural Biology
(MOSB)

dirk.heinz@helmholtz-hzi.de



Prof. Dr. Rolf Müller

Department of Microbial Natural Products,
HIPS (MINS)

rolf.mueller@helmholtz-hzi.de

New Options for Rational Biosynthetic Engineering of Novel Polyketide Drugs

Many medically relevant molecules such as rifamycin, erythromycin, rapamycin or epothilone, are natural products of the polyketide type. These complex molecules are assembled from activated short chain carboxylic acid precursor molecules in a stepwise fashion. However, the structural variability of introduced sidechains was considered to be limited due to the dependence on typical cell metabolites such as malonyl-CoA acting as precursors. Recently, a newly discovered family of enzymes, the crotonyl-CoA carboxylase/reductases (CCR), has been shown to generate a wide variety of additional precursor molecules thus explaining the enormous observed chemical diversity of polyketides. Understanding the structure and mechanism of this enzyme class thus should pave the way for engineering novel drugs.

Terrestrial bacteria, such as *Streptomyces* and Myxobacteria, are a true treasure trove of medically relevant small molecules. Most of them are so-called polyketides, which are used *e.g.* as antibiotics (erythromycin) or as immunosuppressants (tacrolimus). These polyketides are formed stepwise from precursors by huge multimodular enzyme complexes called polyketide synthases (Wilkinson & Micklefield, 2007). This mechanism nicely resembles the assembly lines of car manufacturers (Weissman & Müller, 2008). The first module recognizes the first building block and covalently binds it to way stations in the assembly line. Next, the second module is loaded with a second building block and catalyzes the condensation of the two building blocks in a Claisen-type ester condensation. Subsequently, the intermediate is delivered further to the next module, which installs another building block to the growing chain. After several rounds of condensation and subsequent reductive steps, the last module releases the mature polyketide molecule.

In principle, altered and ideally pharmaceutically improved variants of known drugs or even completely novel substances can be generated by extending the spectrum of building blocks. However, the condensation chemistry employed

requires a dicarboxylic acid for each carbon-carbon bond formation within the elongation step because decarboxylation serves as the energetic driving force of the reaction. In most cases the extender unit malonyl-CoA, derived from primary metabolism, is used, leading to a chain extension by two carbon atoms resulting in an intermediate not carrying a side chain (Fig. 1A). The extension with methylmalonyl-CoA, correspondingly, incorporates a methyl group as side chain. However, the structures of many described natural products cannot be explained by the incorporation of these two commonly available extender units (Fig. 1B). The formation of these side chains would require unusual building blocks such as ethylmalonyl-CoA, chloroethylmalonyl-CoA or hexylmalonyl-CoA.

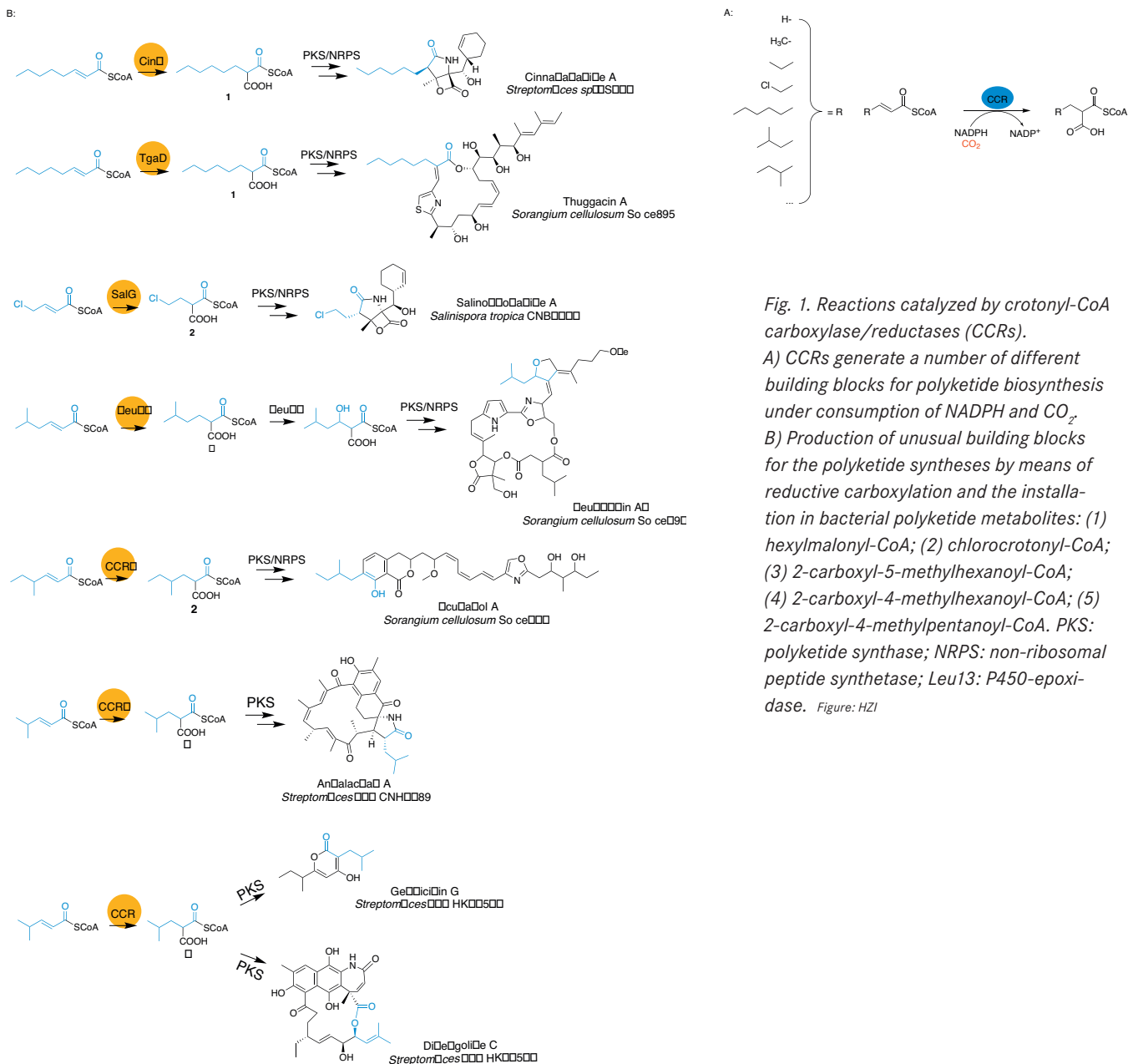

However, no biochemical transformations were known that could yield such products from primary metabolites until the group of Georg Fuchs (Freiburg) recently described an unprecedented enzyme, which can catalyze the conversion of crotonyl-CoA to ethylmalonyl-CoA (Erb et al, 2007). Importantly, a number of homologues to the encoding gene were found in diverse secondary metabolite biosynthetic gene clusters (Erb et al, 2009) indicating that unusual side chains in polyketides may indeed be generated employing building blocks not stemming from primary metabolism, but produced by additional specific enzymes, which were named crotonyl-CoA carboxylase/reductase (CCRs) according to their first described representative. These enzymes utilize CoA esters of unsaturated fatty acids (e.g. 2-octenoyl-CoA) as substrates and catalyze a reductive carboxylation to generate the ready-to-use building blocks of polyketide synthases (2-carboxyoctanoyl-CoA / hexylmalonyl-CoA) (Fig. 1A) under consumption of NADPH and CO₂.

For a while it remained unclear how exactly these unusual reactions proceed and how the CCRs recognize their substrates. For this reason, and because of the structural variety of polyketides under study in our laboratories, we were inspired to perform structural and biochemical studies on the CinF enzyme from *Streptomyces* sp. JS360 (Quade et al, 2012). CinF takes part in the biosynthesis of cinnabaramides, polyketides that can be applied as potential fungicides by inhibiting the fungal proteasome. The structural characteristic of the cinnabaramides lies in their unusual hexyl side chain, which derives from incorporation of the unusual building block hexylmalonyl-CoA. We could indeed show that this building block is provided by CinF employing 2-octenoyl-CoA as its substrate by reductive carboxylation (Rachid et al, 2011). However, CinF is also able to recognize substrates containing a shorter side chain, such as crotonyl-CoA (butenoyl-CoA), while typical CCRs can only convert crotonyl-CoA and are inactive towards bulkier substrates such as 2-octenoyl-CoA.

We were able to solve the crystal structure of CinF in complex with its bound substrates 2-octenoyl-CoA and NADP at high resolution. Thorough analysis of the structure provided elegant and clear explanations of the findings described

Fig. 2. Structure of CinF.

A) The stereo image of the quaternary structure of CinF showing the dimer of dimers fold. The monomers are shown as cartoons in orange, blue, yellow and red. The ligands are shown as sticks.
B) Representation of one monomer and the interface with the dimer partner. Helix: blue; β -sheet: red; loops: white; NADP⁺: green; 2-octenoyl-CoA: pink. Figure:HZI

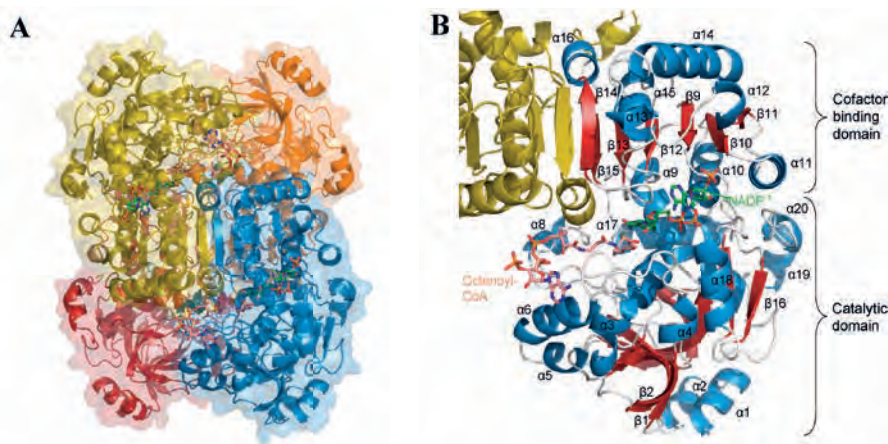

above. CinF forms a tetramer (dimer of dimers), with the flexible CoA part of the 2-octenoyl-CoA being situated in a furrow between two respective monomers (Fig. 2 and 3A, B). The well-defined 2-octenoyl part instead is accommodated in a hydrophobic pocket inside each monomer (Fig. 3C). Compared with the unpublished structure of a CCR homologue from primary metabolism, which can only utilize crotonyl-CoA as substrate, the hydrophobic pocket of CinF is distinctly larger (Fig. 4A). This observation can be attributed to two amino acid mutations occurring in the substrate binding pocket: In case of CinF, the two small amino acids Ala163 and Gly362 provide sufficient space for the accommodation of 2-octenoyl-CoA, whereas the two bulkier amino acids Ile171 and Phe370 at the corresponding positions of other primary CCRs restrict the hydrophobic pocket and prevent binding of substrates exhibiting a longer side chain. Both residues in CinF were mutated to the corresponding CCR residues. Biochemical characterization of the resulting enzyme variants showed a loss of activity towards 2-octenoyl-CoA; crotonyl-CoA, however, was still converted to ethyl-malonyl-CoA indicating that indeed these two positions define the substrate specificity of CCRs.

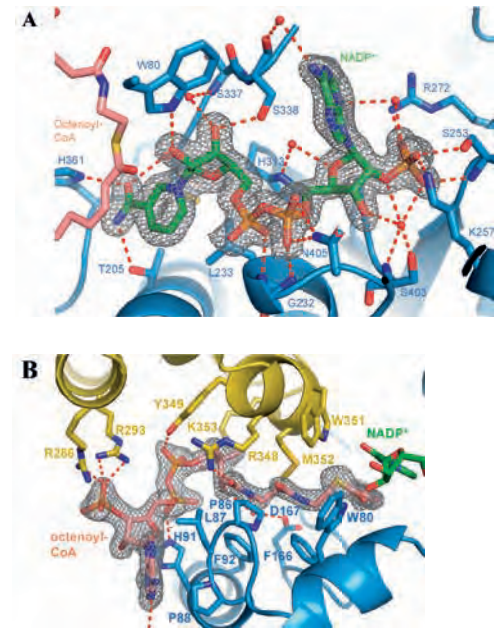
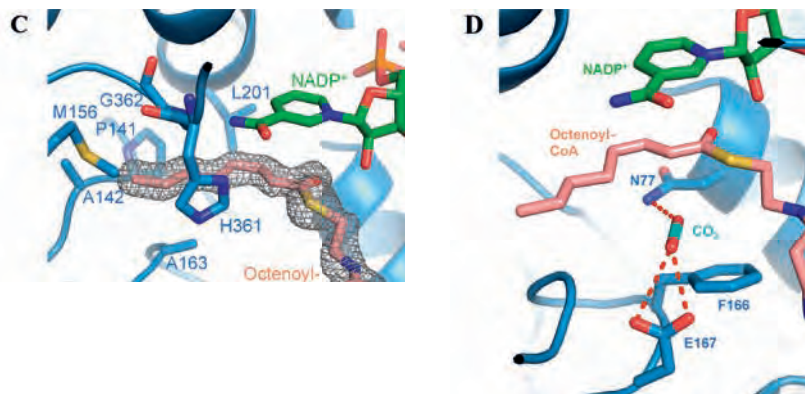

Fig. 3. Ligand binding by CinF. CinF is shown as a cartoon and in sticks; one chain is colored blue and the other one is yellow. NADP⁺: green; 2-octenoyl-CoA: pink. The electron density is shown at 1.0 as gray mesh.

A) Interactions between NADP⁺ and CinF showing the residues responsible for cofactor binding.

B) Binding of 2-octenoyl-CoA at the interface between these two monomers.

C) Close-up of the hydrophobic substrate binding pocket of the 2-octenoyl-chain.

D) A model showing how CO₂ (shown as cyan sticks) can be bound to the active center of CinF. Figure: HZI

Another CCR involved in biosynthesis of the proteasome inhibitor salinosporamide, SalG, whose biochemical investigation was already conducted, is able to reductively carboxylate the unusual building block chlorocrotonyl-CoA. Therefore, a different substrate binding pocket of SalG was expected and based on its high sequence similarity to CinF, modeling of the architecture of its substrate binding pocket was feasible (Fig. 4B). It turned out that SalG also possesses an alanine in position 163, just like CinF, but an isoleucine in position 362. The latter occupies less space than phenylalanine in typical CCRs, but confines the binding pocket in comparison to the glycine in CinF, thus allowing for binding of medium-sized chlorocrotonyl-CoA.

The structure of CinF in complex with its bound substrates also gives insight into the unique reaction mechanism. NADP firmly binds to a loop between two domains of the protein, whereas the reactive nicotinamide group is placed close to the 2-octenoyl-CoA binding pocket (Fig. 3A, C). The double bond of

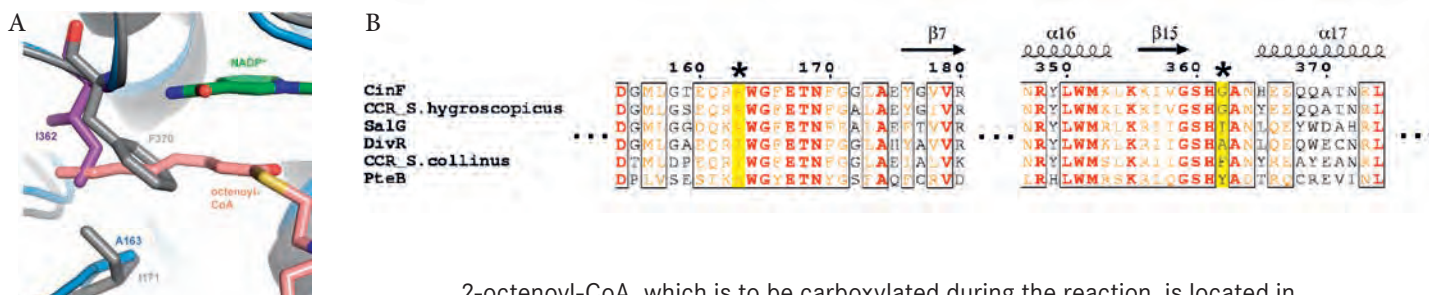

Fig. 4. Comparison of the active center of CinF with that of other CCR homologues. **A)** Overlay display of the substrate binding sites of CinF (blue) and the CCR from *S. collinus* (gray). The binding site of CinF is lined by small residues (Gly362 and Ala163), while this binding site is blocked by Ile171 and Phe370 in the CCR from *S. collinus*. This explains why CinF is able to employ 2-octenoyl-CoA as a substrate while the other CCRs are not. In SalG, instead of the glycine residue an isoleucine is found. This residue was modeled into the ligand-binding site of CinF (purple). The resulting binding pocket is a bit larger than that in typical CCRs, which explains why SalG is able to use the larger Chlorocrotonyl-CoA instead of the usual crotonyl-CoA. **B)** Truncated structure-based sequence alignment of CinF with a putative CCR (*S. coelicolor*), a putative 2-octenoyl-CoA carboxylase-reductase (*S. hygroscopicus*), SalG (*S. tropica*), DivR (*Streptomyces sp. HK10576*), a putative CCR (*S. collinus*, PDB code 3KRT) and the 2-octenoyl-CoA carboxylase-reductase PteB (*S. avermitilis*). The positions of the residues determining the substrate specificity are marked in yellow and with an asterisk. *Figure: HZI*

2-octenoyl-CoA, which is to be carboxylated during the reaction, is located in parallel orientation to the nicotinamide group of NADP. The reactive hydrogen atom of NADPH is thus located at a perfect position for double bond reduction. In the absence of CO₂ a slower side reaction was observed in the course of which the double bond is only reduced but not carboxylated. Despite intense efforts, we were not able to obtain a structure of CinF in complex with bound CO₂ and therefore had to rely on homology-based computer modeling to position CO₂ into the active site of CinF (Fig. 3D). In this structural model, CO₂ is able to form hydrogen bonds to Asn77 and Glu167, while hydrophobically interacting with Phe166. Interestingly, a very similar CO₂ binding pocket was described in the structure of the unrelated Rh-protein from *Nitrosomonas europaea* (Li et al, 2007). Indeed, mutations of the asparagine or glutamate led to the complete abolishment of the carboxylation activity of CinF, without abrogation of its reduction activity. CO₂ thus most likely is situated in parallel and in direct vicinity to the reactive double bond of 2-octenoyl-CoA within the binding pocket and opposite to the nicotinamide group of NADP. Consequently, product formation can proceed in a concerted fashion: The hydride of NADPH can attack the double bond of 2-octenoyl-CoA from above and the reaction can immediately proceed by attack of CO₂.

Our successful structure-function analysis of CinF now sets the stage to deliberately change the size of the substrate binding pocket of CCRs in a targeted fashion, in order to rationally modify their substrate specificity. It is thereby conceivable to generate novel and even unnatural building blocks for the polyketide biosyntheses. By incorporating these novel building blocks into polyketide backbones a number of variants of known structures with improved properties, e.g. higher effectiveness or fewer side effects, could be produced. However, it has to be taken into account that polyketide synthases will have to be biochemically fine-tuned to accept, incorporate and extend such novel extender units: a lengthy, but extremely worthwhile goal.



Dirk Heinz, born 1960, studied chemistry at the University of Freiburg; Dipl.-Chem. 1986; PhD at the Biocenter of the University of Basel, Dr. phil. nat. 1990; Postdoc at the University of Oregon (Eugene, USA) 1990-1993; Scientific Assistant at the University of Freiburg 1993-1998; Habilitation in Biochemistry at the University of Freiburg 1998; Junior Research Group Leader at the GBF 1998-2002; Head of Department of Structural Biology at the GBF 2002-2003; Head of Division of Structural Biology at the HZI 2003-2008; Honorary Professor

at the Technical University Braunschweig 2003-2012; Since 2009 Head of Department Molecular Structural Biology at the HZI; Since 2011 Scientific Director of the HZI; Since 2013 Full Professor at the Technical University Braunschweig; Founder and speaker of the GBM study group “Structural Biology” 2005-2012; Since 2008 Elected Member of EMBO; Since 2009 Elected Corresponding Member of the Akademie der Wissenschaften in Hamburg; Since 2012 Member of the Executive Board of DZIF German Centre for Infection Research.

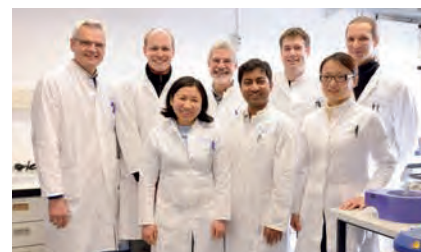

Dirk Heinz with his work group. Photos: HZI

Rolf Müller studied pharmacy at the Bonn University and did his PhD at the Department of Pharmaceutical Biology, where he also worked as a postdoc. In 1996, he went to the Department of Chemistry at the University of Washington in Seattle, USA. At that time, he already began to investigate the production of antibiotics in bacteria and two years later came back to Germany as a junior group leader at the German Research Centre for Biotechnology (GBF, now HZI) in Braunschweig. In 2000, he completed his habilitation thesis at the Technical University Braunschweig about the biosynthesis of antibiotics in actinomycetes and myxobacteria. Since October 2003, Rolf Müller holds a chair as professor of pharmaceutical biotechnology at the Saarland University and in 2009 became the head of the Helmholtz-Institute for Pharmaceutical Research Saarland (HIPS). Furthermore, he heads the department of “Microbial Natural Products” (MINS) and co-founded the PharmBioTec GmbH in Saarbrücken. His research was rewarded with the Phoenix-Pharmacy Research Award on two occasions (2001, 2007), the DECHEMA Award for Natural Products Research (2002), the BioFuture Award of the Federal Ministry for Education and Research (BMBF, 2003) and the DECHEMA Award of the Max-Buchner Research Foundation (2010). In 2012 he became a member of the National Academy of Science and Engineering (acatech; Deutsche Akademie der Technikwissenschaften).

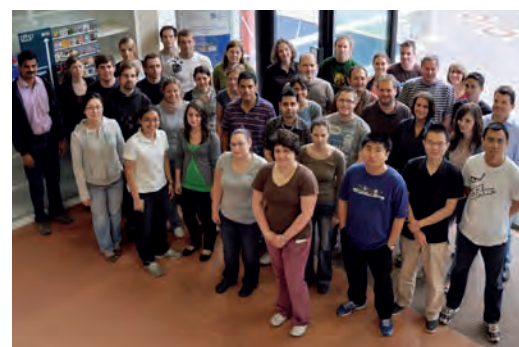

Rolf Müller with his work group. Photos: HIPS, HZI

Publications

Erb, T.J., Berg, I.A., Brecht, V., Müller, M., Fuchs, G., & Alber, B.E. (2007) Synthesis of C5-dicarboxylic acids from C2-units involving crotonyl-CoA carboxylase/reductase: The ethylmalonyl-CoA pathway. *Proceedings of the National Academy of Sciences USA* **104**, 10631-10636.

Erb, T.J., Brecht, V., Fuchs, G., Müller, M., & Alber, B.E. (2009) Carboxylation mechanism and stereochemistry of crotonyl-CoA carboxylase/reductase, a carboxylating enoyl-thioester reductase. *Proceedings of the National Academy of Sciences USA* **106**, 8871-8876.

Li, X., Jayachandran, S., Nguyen, H.H., Chan, M.K. (2007) Structure of the *Nitrosomonas europaea* Rh protein. *Proceedings of the National Academy of Sciences USA* **104**, 19279-19284.

Quade, N., Huo, L., Rachid, S., Heinz, D.W., & Müller, R. (2012) Unusual carbon fixation gives rise to diverse polyketide extender units. *Nature Chemical Biology* **8**, 117-124.

Rachid, S., Huo, L., Herrmann, J., Stadler, M., Köpcke, B., Bitzer, J., & Müller, R. (2011) Mining the cinnabaramide biosynthetic pathway to generate novel proteasome inhibitors. *ChemBioChem* **12**(6), 922-931.

Weissman, K.J., & Müller, R. (2008) Protein-protein interactions in multienzyme megasynthetases. *ChemBioChem* **9**, 826-848.

Wilkinson, B., & Micklefield, J. (2007) Mining and engineering natural-product biosynthetic pathways. *Nature Chemical Biology* **3**, 379-386.



Author

Dr. Dagmar Wirth

Research Group Model Systems for Infection and Immunity (MSYS)

dagmar.wirth@helmholtz-hzi.de

Rational Genome Engineering – on the Generation of Cell and Mouse Models for Infection

The need for cell and animal models for infection

In many areas of biomedical research, including infection research, experiments on cells and animals are conducted to get a deeper understanding of the function and regulation of genes, in the origin and molecular pathogenesis of diseases and also to develop novel therapeutic strategies. Such model systems are often limited, e.g. when the experimental settings do not reflect the situation in patients, in case of host restrictions (such as found for hepatotropic viruses) or if certain experimental conditions need to be modulated over time. The genetic modification of cells and animals represents a unique tool to rationally design model systems so that they can provide experimental conditions that are naturally not available. Thereby, tailor-made experimental systems with a plethora of different properties become conceivable and can pave the way for new avenues to address open questions.

The research group Model Systems for Infection and Immunity (MSYS) at HZI is focusing on the establishment of novel cellular and mouse based model systems. For this purpose, novel experimental approaches are developed for applications in infection research.

***In vitro* cell models with physiological properties**

Cell cultures are of particular interest since they allow the investigation of biological questions in the smallest autonomous entity and thereby avoid the complexity of an animal. However, the application of primary cells isolated directly from the organism is limited due to the low number and limited availability of many cell types. This accounts in particular for human cells. Moreover, most primary cells cannot be expanded *in vitro* to the numbers required for the various applications. Immortalized cell lines of different tissues and species have been isolated from tumor material. They can also be generated by transfer of genes that promote cell proliferation, *i.e.* by immortalization. Cell lines can be cultivated unlimitedly and thus represent a valuable source for many *in vitro* studies. In most cases, however, these cell lines have lost their original properties and thus no longer mirror the respective cells in the body. Accordingly, the relevance of data obtained with these lines is limited and restricted to specific questions. Moreover, the fact that these cell lines proliferate in an uncontrolled manner is

an important difference to primary cells which cycle only rarely in their natural niche in the organism. This limits the benefit of immortalized cell systems for many applications *in vitro*, but also for potential regenerative approaches.

To attack this dilemma, a novel immortalization strategy has been developed. The strategy implies the immortalization of cells in a way that the proliferation activity is controlled so that one can put a time limit on cell growth. To this end, synthetic control elements that provide tight transgene regulation (May et al., 2008) are employed for expression of proliferation control genes. Once introduced into primary cells these synthetic tools allow to control onset and cessation of the expression of proliferation inducing genes and thereby the cell cycle. By using externally added small molecules that regulate the introduced control elements, the cells can be maintained in the expansion phase. The strategy used is depicted in Fig. 1. A Doxycycline controlled promoter was used to drive expression of different immortalizing genes. In the presence of Doxycycline, cell expansion is achieved while in the absence of the inducer the cells undergo proliferation arrest (May et al., 2004). Using this procedure, a number of different cell lines of mouse and man could be established (Table 1). Importantly, it could be demonstrated that following this procedure, the cells can be expanded on demand but still retain their original properties (May et al., 2010). This was proven by functional implementation of the human cells in mice. It could be demonstrated that conditionally immortalized human endothelial cells can form functional vessels and overtake their intrinsic function once exposed

Fig. 1. Strategy for controlled expansion of cells by conditional immortalization
A: An autoregulated, Doxycycline (Dox) dependent expression vector for Dox controlled expression of immortalizing genes. In presence of Dox, the transactivator rtTA binds to the P_{TET} promoter and activates the immortalizing genes in a reversible manner.

B: In presence of Dox (+) cell expansion is achieved, while with drawal of Dox (-) results in maintenance of the cell number.
C: Conditionally immortalized fibroblasts were cultivated for 5 days in presence or absence of Dox and subsequently stained.

Figure: HZI

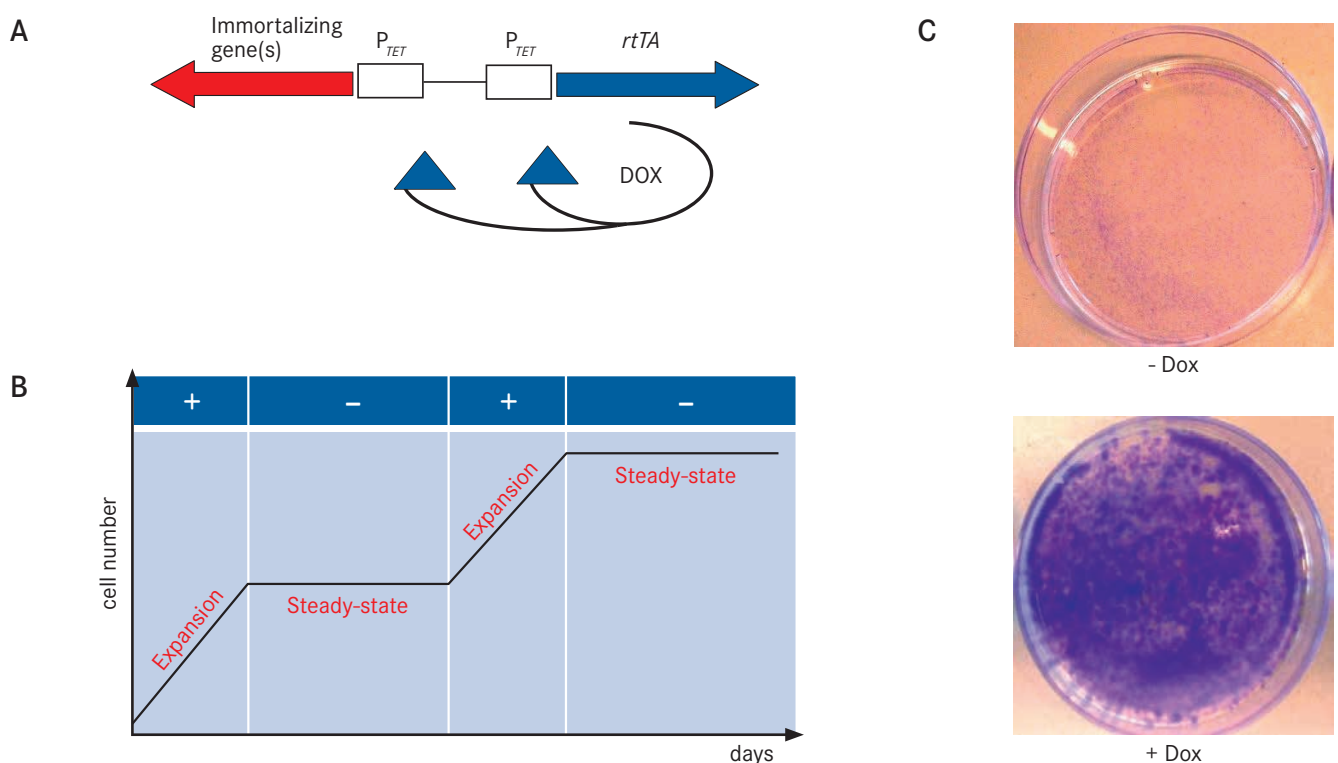

Cell type			Immortalization	
			constitutive	conditional
Fibroblasts	mouse	embryonal	+	+
	mouse	ear	+	+
	man	foreskin	+	+
Endothelial cells	mouse	lung	+	+
	mouse	liver	+	+
	human	lung	+	+
	human	cord	+	+
Osteoblasts	human	bone	+	not done
Hematopoietic stem cells	murin	bone marrow	+	-
Hepatocytes	mouse	liver	+	+

Table 1. Characterized cell lines

to a suitable niche *in vivo* (Fig 2). Moreover, the novel endothelial cell systems of man and mice proved to be susceptible to infection of various pathogens including Group A Streptococci (S. Talay, unpublished observations), KSHV (Alkharsarh et al., 2011) and MCMV (Dag et al., submitted) which demonstrates the potential of these cells for infection research. Based on this proof of concept, current activities focus on the development of growth controlled cells from hepatic tissues and epithelial cells. The results confirm the benefit of the conditional immortalization approach for expansion of these cell types.

Fig. 2. Examples for novel immortalized cell lines

A. Conditionally immortalized human endothelial cells maintain the capacity to form tube like structures in matrigel in vitro. Grafting of the cells in immune compromised mice results in formation of perfused vessels.

B. Immortalized mouse hepatocytes show hepatic markers such as albumin and Ecadherin. Upon transplantation into FAH^{-/-} mice, they show successful engraftment. Figure: HZI

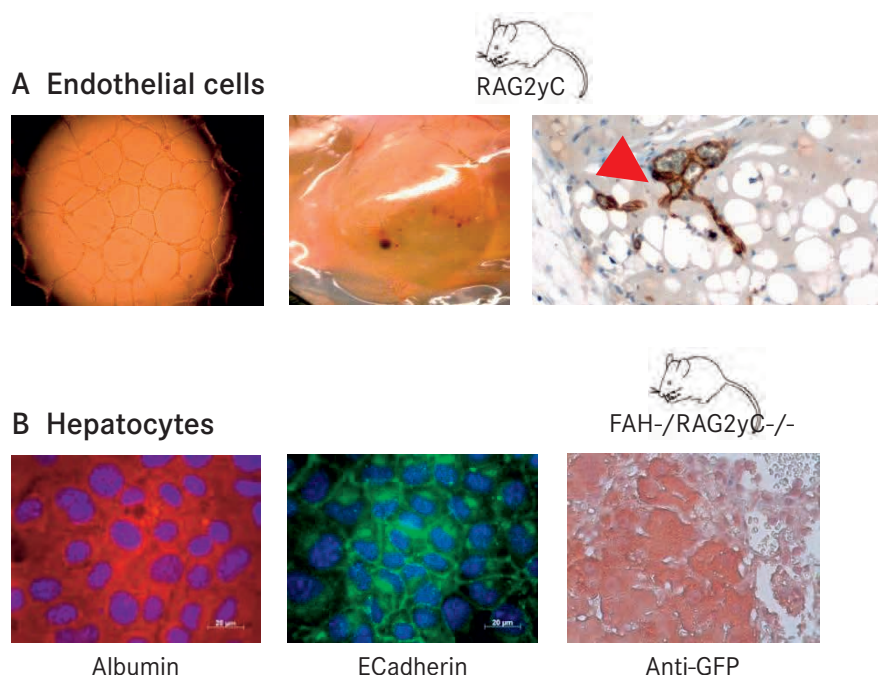

While this activity started as a pure scientific activity more than a decade ago, it is now complemented by a start-up company (InScreenEx) funded by Dr. Tobias May and Dr. Roland Schucht, former members of the research group MSYS. InScreenEx focuses on the generation and commercialization of the novel cell systems in particular for screening purposes, thereby teaming up with MSYS to bundle up resources. To extend this concept, and to get hands even on cell types in which the above mentioned approach is not satisfactory, the current focus is on the screening and identification of particular (sets of) proliferation inducing genes that support immortalization and maintenance of the properties of specific cell types.

A novel development is the application of conditionally immortalized cells for expansion of iPS (induced pluripotent stem) cell derived cells. iPS cells have been recently shown to provide a source for generation of various patient-specific cell types upon *in vitro* differentiation. However, both the efficiency of generation of iPS cells (reprogramming) and also their differentiation to the tissues of choice are inefficient, highly stochastic processes. Moreover, the generated differentiated cells do not proliferate. Accordingly, only limited numbers of the differentiated cell types can be achieved. We could demonstrate that the conditionally immortalized cells are susceptible for reprogramming to induced pluripotent stem cells. Upon expression of reprogramming factors, conditionally immortalized fibroblast (CI-MEFs) and endothelial cells (CI-LSECs) have been reprogrammed to iPSCs. These cells can then be subjected to *in vitro* differentiation. It could be demonstrated that in the differentiated cells the proliferation cassettes can be activated again. Thereby, the differentiated progeny can be expanded (Maeda, Wirth et al., manuscript in preparation). This paves the way for the application of conditionally immortalized patient cells for research, for screening of novel compounds and also opens new perspectives for regenerative approaches.

Road to precision: predictable transgene expression by targeted chromosomal integration

The generation of genetically modified cells involves the transfer of recombinant DNA (*e.g.* plasmids) encompassing the regulatory elements (promoters) as well coding sequences for proteins of choice. Upon transfer to the cells and concomitant activation of cellular repair mechanisms that sense and eliminate broken DNA, the recombinant DNA is integrated into the cellular chromosomes. As a result, the recombinant DNA will be transduced to daughter cells upon cell division as part of the cellular chromosome. However, for stable expression, the nature of the integration site turns out to be one crucial factor that affects the level, stability and regulation of transgene expression. Although the genome of various species has been sequenced, our knowledge on the sequence-based gene regulation mechanisms and constituting regulatory cascades is limited. Thus, the impact of a specific integration site on transgene expression remains an unpredictable parameter. To overcome this limitation, screening is used to identify those integration events that meet the requirements for transgene

expression (e.g. a stable or a regulated expression). This imposes a problem, in particular when screening is limited, such as the identification of appropriate integration sites for the generation of transgenic mice (see below).

For the development of novel cell or mouse based systems, strategies are required to implement genetic modifications in a predictable, reliable, and, most importantly, effective way. We have developed highly effective protocols to guarantee that genetic modifications will have the desired effect in cells and/or transgenic mice. As such, genetic elements to control gene functions – so-called expression cassettes – are not randomly integrated into the cell's chromosomes but targeted to pre-selected chromosomal loci. This allows ruling out the negative impact of regulatory elements that are frequently associated to randomly chosen chromosomal sites. Moreover, this allows to ensure tight regulation of synthetic expression cassettes that can be externally controlled and switched *on* or *off* on demand. Different methods are available to specifically target expression cassettes to chromosomal loci of choice (Fig 3). Among these, homologous recombination is a complex and *per se* rather inefficient method which is masked by illegitimate recombination in many cell lines. Its efficiency is increased upon introducing double strand breaks that can be introduced by employing upcoming methods based on the design of site specific nucleases such as Zn finger nuclease (ZFN), TAL nucleases or the CRISPR/Cas9 nuclease. However, the particular chromosomal site that provides the expected expression phenotype after integration of vector cassettes cannot be predicted and has to be identified experimentally.

Fig. 3. Strategies for controlled genetic manipulation of cells and mice
If the chromosomal site for genetic modification is known, it can be targeted by homologous recombination. Recently emerging methods for generation of specific DNA double strand breaks such as Zn finger nuclease, TALE nuclease or the CRISPR/CAS9 based nuclease systems are employed to increase the efficiency of homologous recombination. In case the optimal site is not defined, screening is performed to identify the chromosomal sites that give rise to the desired expression pattern. To re-use the identified chromosomal site, the screening cassette will be flanked with recombinase target sites (blue and red triangle) that allow for efficient targeting of the gene of interest flanked by the same set of sites.

Figure: HZI

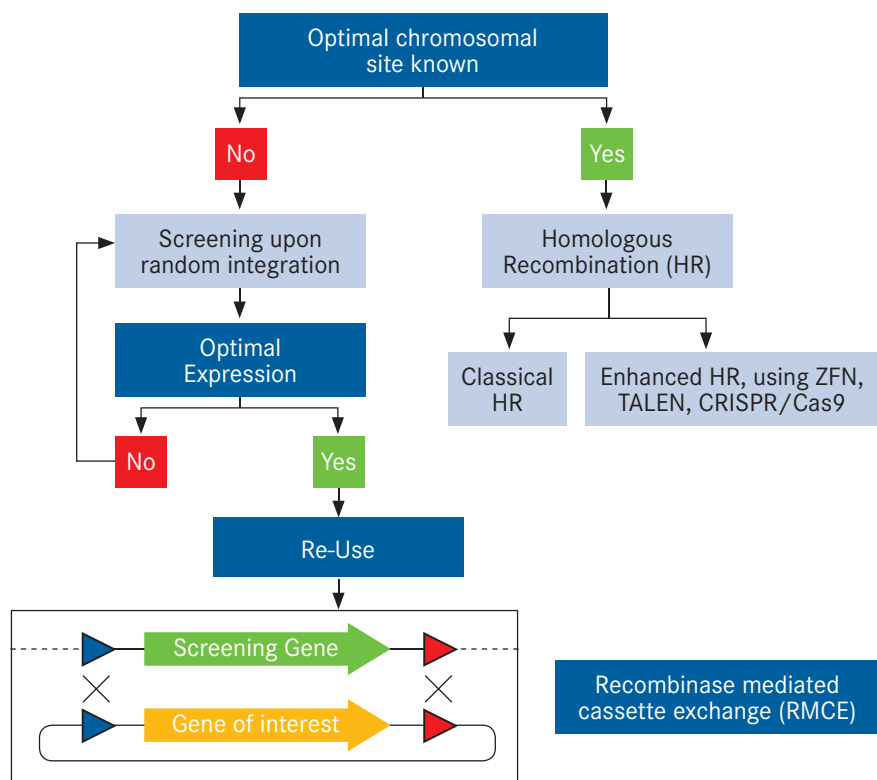

We followed a strategy that is based on the screening of integration sites with particular properties and the tagging of these sites with small (34 or 48bp) sequence tags that represent targets for the respective site specific recombinases such as Cre and Flp. By flanking the screening cassettes with sets of heterologous recombination target sites, recombinase based site specific cassette exchange is achieved (RMCE, recombinase mediated cassette exchange). Combined with an efficient selection protocol, this method confers targeting of virtually 100% (Fig. 4). Such strategies have been exploited for screening and exploitation of particular chromosomal sites for various applications (e.g. Nehlsen et al., 2009; Gama-Norton et al., 2010). It could be demonstrated that – as long as the main regulatory elements are preserved – the targeting of pre-screened sites indeed leads to predictable gene expression.

Transgenic mouse models for infection research

RMCE (see above) has particular advantages for the generation of novel transgenic mouse models since it allows rapid and highly efficient integration of expression cassettes into defined loci of pluripotent embryonic stem cells. Embryonic stem cells represent the basic material for the generation of transgenic mice, which involves either their injection into blastocysts or the aggregation with tetraploid embryos and subsequent transplantation to foster mice. Thus, the genetic modification of embryonic stem cells will directly translate into the generation of genetically modified mice. Technologies that allow the specific modification of defined genomic sites in these cells are thus of pivotal interest. This in particular concerns homologous recombination. The increased efficiency

Fig. 4. Principle of RMCE and successful chromosomal integration
A. A pre-screened integration site is tagged with a set of two non-interacting recombinase target sites (blue and red triangle) and a non-functional resistance marker (Δ Neo). Targeted integration of cassettes of choice flanked with the same set of via RMCE can be achieved by specific activation of a selection marker that allows isolating correctly targeted cell clones.
B. The efficiency of this method was determined by PCR. The percentage of correctly targeted clones from G418^R clones is indicated.
C. Applications of RMCE: Targeted integration of cassettes results in isogenic cells; the expression level of the generated clones is comparable to the parental clone in cell lines and also in transgenic mice.

Figure:HZI

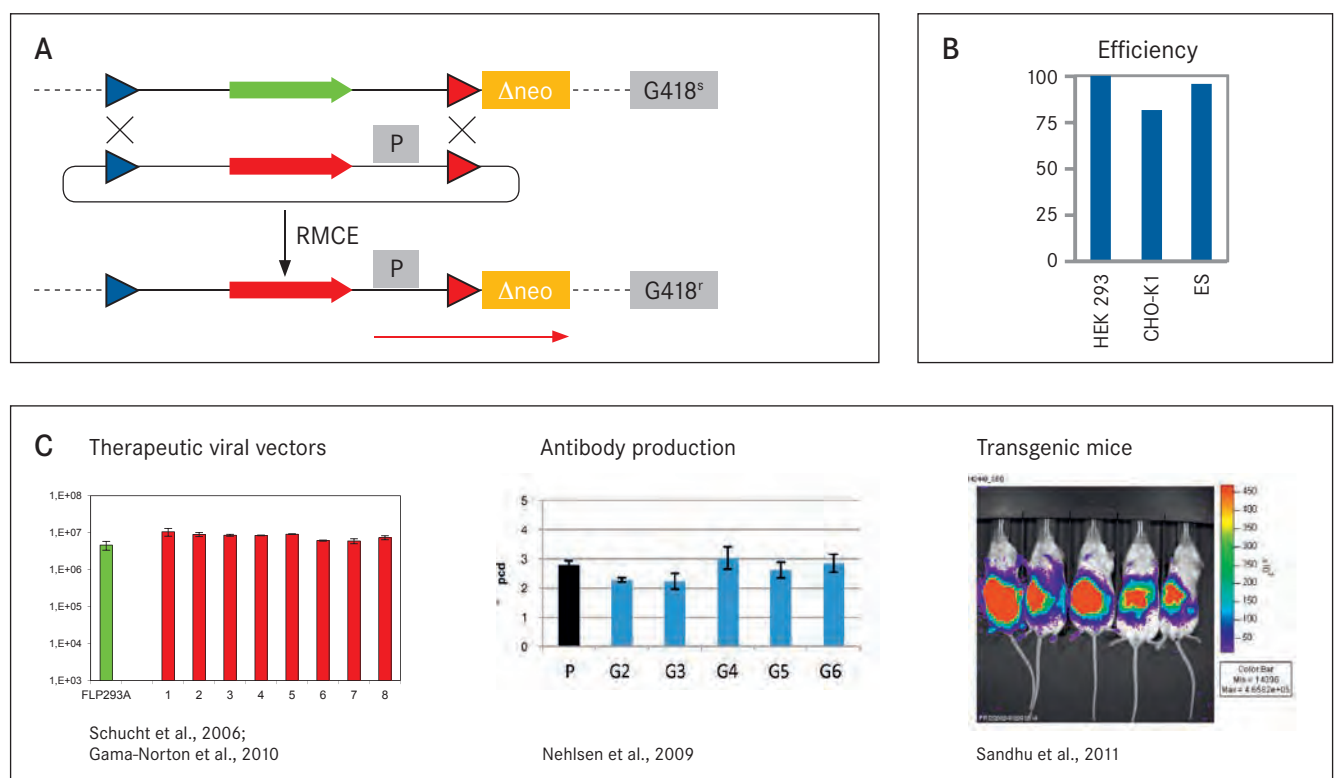

upon combining this method with site specific induction of double strand breaks (see above) now paves the way for precise modification of virtually any loci. This particularly applies for the generation of knock-in and knock-out animals that represent specific modifications at particular sites. Beside this, synthetic expression cassettes are used in the context of the mouse genome for expression of a plethora of transgenes such as pathogen derived genes, dominant negative mutants of cellular genes but also the expression of regulatory RNAs such as shRNAs and microRNAs that is used to downregulate endogenous genes. For these applications, recombinase based RMCE is of benefit for exploiting the properties of a particular chromosomal site. Due to the unprecedented efficiency of recombinase based genetic manipulations and the short recombination sequences, this is the method of choice for these applications: indeed, screening is reduced to a minimum and the process of generation of transgenic mice speeds up. Importantly, the replacement of a reporter for a gene of interest at a particular chromosomal site will result in mice with the very same expression pattern. Thus, the expression characteristics are highly predictable. Importantly, the Flp recombinase based tag-and-target approach in embryonic stem cells can be combined with classical Cre/loxP based strategies for tissue specific transgene activation (Sandhu et al., 2011). Particular applications comprise the design of transgenic mouse models that allow mimicking features of complex diseases such as viral induced hepatitis in a controlled manner (Cebula et al., in revision). A number of different chromosomal sites in the mouse genome are available for recombinase based targeted integration. Due to the high advantage and robustness associated with this method, tagged embryonic stem cells have been implemented into the portfolio of the recently established service unit transgenic mice at the HZI (TGSM). This unit is dedicated to establish novel transgenic mouse models for infection research in collaboration with researchers from the centre.

Recent developments in molecular biology allow the design of cell and mice-based on controlled genetic manipulations. Together with the emerging field of synthetic biology these strategies will become interesting options for the design of tailor-made experimental models that allow to specifically addressing complex questions in biomedical research.

Dagmar Wirth studied chemistry in Braunschweig. Her interest in genetic engineering of mammalian cells started as part of her doctoral work at GBF – today’s HZI – with a special focus on chromosomal elements that affect gene expression. As a Postdoc, she conducted research on recombination in mammalian cells and viruses and developed recombinant viruses for application in biotechnology and gene therapy. Since 2004 she is head of the R&D project ‘Cellular Models’, since 2007 she is head of the research group ‘Model Systems for Infection and Immunity’ and since 2012 she leads the service unit ‘Transgenic Mice’. The current focus of her work lies within the development of cell and mouse systems that provide tight control of transgene expression.



Following her work as a scientist in the Department of Clinical Immunology at the Medical University in Hannover, she returned to GBF in 2004 to assume her current role as principal investigator for the project ‘Cellular models’ and as head of the research group ‘Model Systems for Infection and Immunity’.



Dagmar Wirth and her work group.

Photos: HZI/Hallbauer & Fioretti

Publications

Alkharsah, K.R., Singh, V.V., Bosco, R., Santag, S., Grundhoff, A., Konrad, A., Sturzl, M., Wirth, D., Dittrich-Breiholz, O., Kracht, M., et al. (2011) Deletion of Kaposi’s sarcoma-associated herpesvirus FLICE inhibitory protein, vFLIP, from the viral genome compromises the activation of STAT1-responsive cellular genes and spindle cell formation in endothelial cells. *Journal of Virology* **85**, 10375-10388.

Gama-Norton, L., Herrmann, S., Schucht, R., Coroadinha, A.S., Low, R., Alves, P.M., Bartholomae, C.C., Schmidt, M., Baum, C., Schambach, A., et al. (2010) Retroviral vector performance in defined chromosomal Loci of modular packaging cell lines. *Human Gene Therapy* **21**, 979-991.

May, T., Hauser, H., & Wirth, D. (2004) Transcriptional control of SV40 T-antigen expression allows a complete reversion of immortalization. *Nucleic Acids Research* **32**, 5529-5538.

May, T., Eccleston, L., Herrmann, S., Hauser, H., Goncalves, J., & Wirth, D. (2008) Bimodal and hysteretic expression in mammalian cells from a synthetic gene circuit. *PLoS ONE* **3**, e2372.

May, T., Butueva, M., Bantner, S., Markusic, D., Seppen, J., MacLeod, R.A., Weich, H., Hauser, H., & Wirth, D. (2010) Synthetic gene regulation circuits for control of cell expansion. *Tissue Engineering Part A* **16**, 441-452.

Nehlsen, K., Schucht, R., da Gama-Norton, L., Kromer, W., Baer, A., Cayli, A., Hauser, H., & Wirth, D. (2009) Recombinant protein expression by targeting pre-selected chromosomal loci. *BMC Biotechnology* **9**, 100.

Sandhu, U., Cebula, M., Behme, S., Riemer, P., Wodarczyk, C., Metzger, D., Reimann, J., Schirmbeck, R., Hauser, H., & Wirth, D. (2011) Strict control of transgene expression in a mouse model for sensitive biological applications based on RMCE compatible ES cells. *Nucleic Acids Research* **39**, e1.

Schucht, R., Coroadinha, A.S., Zanta-Boussif, M.A., Verhoeyen, E., Carrondo, M.J., Hauser, H., & Wirth, D. (2006) A new generation of retroviral producer cells: predictable and stable virus production by Flp-mediated site-specific integration of retroviral vectors. *Molecular Therapy* **14**, 285-292.

Interview with

Prof. Gerard Krause

Prof. Rafael Mikolajczyk

Dr. Claudia Sievers

Epidemiological Research at the HZI – a new Important Tool

Science at the Helmholtz Centre for Infection Research has acquired a new facet with the introduction of the Infection Epidemiology Department. Epidemiology is the study of the distribution, causes and consequences of both diseases and health in the population. Infection research at HZI has thus acquired new impetus. The following comprises a discussion with Prof. Gerard Krause, Prof. Rafael Mikolajczyk and Dr. Claudia Sievers concerning the tasks and goals of epidemiology at the HZI:

Why do you consider epidemiology to be so significant within infection research?



G. Krause

Gerard Krause: The purpose of epidemiology is prevention and control of diseases. Particularly in infection research, it makes sense to focus on the characteristics of epidemiology because here we have, as opposed to with cancer and other diseases, the aspect of human transmission. If I am able to prevent, by means of vaccination or other measures, an individual from getting an infection, then I have also prevented others thereby from being infected by him. I am able to potentiate effects, and this ultimately constitutes the significance of infection epidemiology.

Rafael Mikolajczyk: Another point is that we have experts for virological and bacteriological problems at the campus. Epidemiologists can now add their expertise regarding these problems by making observations regarding what kind of effects human and animal diseases have at the population level. It is just a continuation of this chain.

Claudia Sievers: Yes, I agree. Epidemiology marks the transition from basic laboratory research into society. It is based on findings that are acquired in the laboratory.

Regarding the topic of epidemiology, there is a strong association at the HZI with the study centre. When the colleagues think of epidemiology, they automatically think of the study centre – and it is in Hanover. Is that correct?

Krause: No. The study centre is just one among many for us, but it remains of course one of the most impressive and comprehensive facilities we have at HZI.

That's probably why it has such a high profile. It was built because we are a part of the national cohort and there it's typical that test patients are examined and interviewed at study centres. Most epidemiologists conduct their research just on the basis of the questionnaires or with data that have been collected in a different context. For example, with registered physicians, in hospitals or with company doctors.... For some studies – and this is actually much more time-consuming – we visit the people in their homes.

Why do you then make this extra effort with the study centre, when this method is not typical and epidemiology is also possible without?

Krause: With the study centre, examinations are possible that otherwise would not occur at all, or not at the required level of quality.

You run an epidemiological laboratory. What is its function and what makes it special?

Sievers: We detect previous infections through the antibodies in the blood and look for current infections in nasal swabs and stool samples. The unique thing here is that the samples that we have taken in the study centre are examined here on the premises. This gives us the possibility of taking special circumstances into consideration in direct discussions with the epidemiologists regarding the analysis.

There are many laboratories on campus. What is different in an epidemiological laboratory?

Sievers: On the one hand, we are developing methods that have not previously existed at HZI. In general, it is standard procedure for classic laboratories to be involved in basic research in which the analysis of samples is more focused on characterization at the molecular level with numerous possible aspects and, moreover, requires only a few human or animal samples – this is analysis at the model level. And then there are the big clinical labs that conduct therapy-relevant pathogen diagnostics for individual patients. We need, in contrast, a facility that allows us – in the context of epidemiological studies with the lowest quantity of samples over many years or decades – to identify highly-standardized special infectiological parameters.

Krause: The difficulty lies in the fact that one is not allowed to change even one method, because a device is up-dated; rather, we have to be able to say in 20 years that a value is comparable with the value that was measured 20 years ago. This is a huge challenge.



C. Sievers



Numerous of neurocognitive assessment instruments are part of the study programme in the National Cohort. Test runs will include memory (episodic, semantic and working memory), motoric coordination (picture: Purdue pegboard), numerical and verbal abilities and an olfactory test.

HZI

Sievers: And on the other hand, as an epidemiological laboratory we also function as the link between epidemiology and basic research. The manner in which we deal with epidemiological data is not the same as data from basic research. Epidemiologists pose other questions and use a different scientific language. Moreover, the quantity of physicians involved in epidemiology is quite high. Thus we are quite close to the medically relevant questions.

Krause: Yes, when a scientist evaluates at what point an infection becomes a problem, it helps when he has previously treated patients himself. And I believe that we are quite able to offer that at HZI.

Is there an intersecting set between the epidemiological laboratory and the other scientists at HZI?

Sievers: Yes, of course, without close collaboration we are not at all able to process the questions among the national cohort. Within the study centre, we will have examined 10,000 individuals over four years. Even if we only examine a small percentage of the overall stool samples in order to characterize intestinal flora, we will still be able to discover links between infections and other diseases. Let's look at a hypothetical case: 500 test subjects have developed diabetes after four years. How do we differentiate the intestinal flora of these individuals from those who have not acquired diabetes? We can only conduct such examinations in a joint effort with the other colleagues at HZI. And added value emerges hereby for the colleagues as well, in that they can use these samples for their own study purposes at the same time. We have thus been able to achieve mutual added value, *per se*, from the epidemiological projects.

Krause: We need to add something else here – the samples by themselves are of no value to us. They acquire their value only through comprehensive characterization by the individual who has made them available: by means of interviews, physical examinations, repetitions of these examinations and observations.

What do you consider to be the added value for scientific development at HZI?

Krause: We are of course still just at the beginning stages, but over the medium term I consider us to be a kind of conveyor belt within the HZI. We bring data from basic research into the application phase and then back again as well. Issues arise at the molecular level, in other words, at the cellular level phenomena are discovered. And we can observe whether or not this same effect is reflected in human beings.

As many as 10,000 test subjects, four years of recruitment efforts, then analysis of the data.... The project has been planned for the long term. I assume that you won't be able to take a break until you have collected enough samples.

Krause: Such examinations as those described by Frau Sievers are executed by us for a very wide variety of studies, not only for the cohort. The cohort is the “Mercedes Benz” among study concepts, but it has clear limitations. The first is the fact that it will take 8 years until we will be able to look back and properly analyse the correlations. Second, it is limited to adults. Third, it is limited to aspects that can only be recorded infectiologically over the long-term – if we see the test subject only once every four years, we won't be able to evaluate, for example, the course of an influenza infection. This is why we carry out additional studies, completely independent of the cohort, which have been conceived for special issues.

Do you have an example?

Mikolajczyk: I am currently setting up a cohort of new-borns. We have the problem with adult cohorts that we cannot track the emergence of immunity and the early diseases in childhood. This is why I started looking for a method of examining the emergence and dispersion of infectious diseases in infancy.

What is a cohort of new-borns?

Mikolajczyk: A cohort is first of all merely a type of study in epidemiology, in which we observe the same study participants over a certain period of time. And with a cohort of new-borns we begin at birth. We will recruit pregnant women and then observe very closely the initial years of child development. We want to record all infections during this time by means of a daily symptom journal that the parents fill out. For example, did the child have diarrhea, runny nose and how severe it was. Whenever infections appear, we will take samples – and this all happens during the first two or three years.

What are you looking for?

Mikolajczyk: We are interested in correlations, for example, between infections and asthma in children. We are seeing an accumulation of asthma in children and pursuing a theory that correlates a decrease in infections and higher standards of hygiene with an observable rise in asthma frequency.



Rafael Mikolajczyk



The protocols for blood sampling and storage of aliquots of plasma, serum, DMSO-preserved viable white blood cells, intact lymphocytes and erythrocytes in a central bio-repository will permit a wide range of laboratory analyses. HZI



The use of touchscreens is growing at a tremendous rate. Touchscreen devices are very intuitive and easy to use; they are very suitable even for study participants who are relatively inexperienced in the use of computers. HZI

Krause: Infectious diseases have two dimensions. First, the immediate disease that we all recognize as the consequence of the infection: diarrhea, respiratory disorders, etc. Second, there also exist – and we want to increase our involvement with this more now at HZI – correlations between infections and diseases that are not usually associated with an infection: obesity, metabolic syndrome, neurological diseases, cardio-vascular diseases.... This is a very exciting field.

You said in the beginning that a large portion of your studies are based on cohorts. Does this mean that you also make use of other study concepts such as cross-section or case-control studies?

Krause: Precisely. We have to accomplish a good mix of studies, because we can not always wait multiple years until we achieve the initial results.

Mikolajczyk: Secondary analysis as well is an exciting field. We are currently drafting a study model, with which we can assess the existing data from the health insurance companies. We can, for example, make deductions about diseases from the prescriptions for certain medications and then assess the anonymous data. In the USA, analyses are often times made from the data banks of hospitals.

Aren't there objections concerning data security when you are granted access to health insurance data? In other sectors as well – data security is a very sensitive area.

Mikolajczyk: It is an area in which strict rules have to be observed. As regards this concrete case, I get anonymous data for the analyses from the health insurance companies, for example, so that there is no possibility of being able to identify patients through data. This connection is severed and even the health insurance company has no possibility of bringing together the data once they have been separated.

Krause: But of course this is a sensitive subject. These applications are very difficult to fill out and are evaluated minutely. Whatever we do, whatever our research has to do with people, extra hurdles are still built in – even when we don't take samples and there is no health risk. The fact that we are collecting very personal data is enough. And by very personal they mean – Were you sick yesterday?

And of course this research reveals very intimate details about the people. You are the direct link between people and infection research, so to speak....

Krause: By all means, yes. We are also working on topics that concern the environment here in Braunschweig. I believe that we will soon be able, as a Helmholtz Centre, to establish a rapport to the people in our surroundings – simply because we are discovering things such as whether we have many or only a few resistant germs in our city. This is an opportunity to be taken more seriously, as a research facility, by the people here.

What is your vision for epidemiology at the HZI?

Krause: I have two visions. I would like to develop studies that raise recommendations, measures and other aspects of prevention against infectious diseases to a scientific level. My relationship to the Robert Koch Institute comes into play here. There we make recommendations to people regarding washing their hands, oral hygiene and so on – but there are few viable studies that examine what actions are useful under what conditions and in what scope. I would like to change that. My second vision is to establish a facility here at HZI that is suitable for answering all such questions. I want to be able to observe in real time how an infection can be transmitted from the grandmother to the grandson to the kindergarten teacher to the husband to the colleagues and the staff and back again to the grandfather or grandmother. To be able to track this development in a scientific manner would be a huge step forward.

Where do you see yourself within this HZI vision?

Krause: That poses other questions such as: Why does one pathogen spread more than another? What pathogen-specific aspects play a role here? And regarding the immunological aspects – why do some people get sick while others don't? And this is what makes us dependent upon the expertise of the colleagues on campus.

Mikolajczyk: Yes, we want to carry out joint projects with the colleagues. We hope that it will be a productive exchange. Questions that emerge in basic research are dealt with by us, thereby creating more questions for basic research.

Krause: We take a look at the overall population, including those individuals who are not yet sick. This allows us to change the perspective. What does a new finding mean, acquired here at HZI, for society?

Thank you for the discussion!



Hypertension is a major risk factor for stroke and myocardial infarction and contributes considerably to overall mortality. In the National Cohort, blood pressure will be measured in a standardized fashion. The values have been categorized according to the classification published by WHO. ^{HZI}

The interview was performed by Dr. Jo Schilling. Dr. Schilling is a freelance science journalist, writing for national and international newspapers, magazines and radio stations. She is specialized in biotechnological, medical and chemical topics.

Interview with

Claudia Körner**Melanie Brinkmann****Christiane Ritter****Luka Cicin-Sain**

The HZI Providing Efforts on the Balance between Career and Family

The Helmholtz Centre for Infection Research is making an effort these days to alleviate the balancing act between career and family. The Center is assisted by the audit berufundfamilie® and they offer, with their Family Office, dynamic support in coping with the daily routine with children. For junior scientists in particular, who are currently planning their careers and have to assert themselves with state-of-the-art research in the world of science, the decision to start a family is a huge challenge. How scientists live at HZI with their young families is described here in a discussion with the director of the Family Office Claudia Körner and the junior scientist group leaders Melanie Brinkmann, Christiane Ritter and Luka Cicin-Sain.

Coordinating career and family is always a challenge – especially if one is seeking a career. Do scientists with young families have to meet different challenges compared to other career groups with families?

Christiane Ritter: I believe that a primary difference when compared to other careers lies in the time flexibility that is characteristic of scientific professions. But this time flexibility is not only a bonus – it amounts to a curse as well. Everyone who would like to advance in his/her field works long hours and energetically; however, I believe that in scientific circles we have a lot more chaos in the course of the daily and weekly routine.



M. Brinkmann

Melanie Brinkmann: The daily routine of a scientist is usually difficult to squeeze into a Monday through Friday, 9 to 5 schedule. We have to be very flexible and write reports or applications on short notice – even on the weekends sometimes. We have to go on business trips a lot, show up for seminars in the evenings and attend conventions...

Luka Cicin-Sain: If both partners work in the scientific sector, mutual flexibility can be quite helpful. My wife does not work in science and is of course less flexible and tied to a specific time schedule. If I have to attend a seminar on short notice it can become difficult for us.

Did you know that you have access to support at the day-care centre through the Family Office at HZI?

Brinkmann: Yes, of course. For our career change to the HZI, it was a must that we could get day-care time for our children. This is why we decided, in order to be able to efficiently plan our daily routine, to move to a place close to the day-care centre and the HZI.

Claudia Körner: We offer our assistance to new staff and try to find an individual solution for everybody. For example, we work together with the day-care centre Sterntaler here in Stöckheim, and there we have a fixed allotment of day-care spaces available. These spaces are always booked up. We also work together with freelance childminders and are in the process of expanding the company-assisted childcare at HZI through planning and implementation of childcare spaces.

Cicín-Sain: My children were already in primary-school age when we arrived here. It wasn't a thing for us. We live in Wolfenbüttel and solved the problem by having my wife take the first year off from work, and the children could later go to daycare in the school. Daycare at HZI was never an issue for us because our children go to the school in Wolfenbüttel – how could they come for childcare on campus?

Are you often times faced with the problems of the Wolfenbütteler families, Frau Körner?

Körner: No, I'm afraid not – they don't come to me if they need help. But the fact that I could, and would, help them if they needed help is important. We will always try to find solutions.



C. Körner



Holiday season at spring time, daily childcare whilst the parents are working HZI

How do you deal with the issue of daycare when there is a business trip planned?

Brinkmann: My husband works in science too, so we have to negotiate about business trips. We agree on the calendar in advance, and if we both have appointments we can turn to our network of babysitters, neighbors and parents. It does become a problem though if the kids are sick, since we have to manage spontaneous organization and coordination.

Ritter: That's a really lucky situation for you. Usually we have such an enormous turnover regarding work sites and, therefore, neither established social networks nor the parents on site at the new living- and work-sites. This is a considerable challenge for scientists with young families. It is really a convenient situation when you have a network available within the facility.

Körner: And that's precisely why the Family Office is there.

You are all also aware of other different research facilities. Are there special characteristics at HZI?

Brinkmann: Yes. I don't think there is such comprehensive and well-established family assistance at other facilities.

Körner: That's nice to hear! We initiated this within the framework of the audit "Combining Career and Family" and started the pilot project in 2009 with 9 children. Ever since then, a lot has changed but it was important to us right from



C. Ritter

Who, how, what? Providing answers for the curious youngsters HZI

Children experimenting and having fun with science HZI





Children enjoying the annual summer festival at HZI ^{HZI}

the start to offer assistance in a form that almost everyone would find agreeable. For example, the fact that it takes place here on campus and the parents don't have the extra trouble of driving so far. They know that their children are in good hands and that they can just dive into the daily work-routine. We also offer – and this is quite unique – a total of six weeks of holiday per year. Every week there is a maximum of 20 spaces available on campus for HZI, DSMZ and Fraunhofer children. The parents pay a moderate parental fee to cover the costs of lunch and activities. The offer is usually booked up, but we keep it so flexible that we hardly have to turn anyone down.

Cicin-Sain: My kids are now too old for that – daycare is only offered up to the age of 12.

Körner: But we could still think about a possible extension...

As parents, do you treat colleagues who also have children differently? Are you much more tolerant?

Ritter: I actually don't have to be more tolerant with my colleagues – those with children are, whether it is a coincidence or not, very productive. Even if they were to say that they'd like to go to the zoo with their kids, there would be no issue there simply because they do their work anyways.

Körner: When the children are sick we can't do anything. But, maybe we just have to restructure things better if we want to combine children with science. This is a great support of course for the actual work as well.



L. Cicin-Sain

Brinkmann: It is of course difficult when a female colleague gets pregnant in the middle of a project and would have to work with an S2 organism. Theoretically speaking, she would have to stop working and that could be fatal for the project. It is a sensitive topic and, for me as junior-scientist group leader, a real problem. In the USA it's not such a big problem – I worked under S2 conditions right up until the time both of my children were born.

As a scientist, you seldom stay longer than 5 years at the same site. Do the children's needs and criteria such as a family-friendly atmosphere at a facility play a role in the decision regarding when you leave and where you go?

Ritter: It actually has to be a change that's comfortable for everyone in the family. But it's in part external forces that determine our fate, and we don't always have the luxury of deciding when we will go. If we had the choice, it would certainly play a role. And we can't forget that, with each move, the children are forced to change their school and have to find new friends.

Brinkmann: I underestimated that, I must admit. It takes two years after a move until the social situation for the kids runs smoothly again.

Cicin-Sain: We've done that three times in all. The older the children are, the harder it gets. When the children are in grammar-school age ('Gymnasium'), moving actually becomes a torture. They lose all of their social networks and arrive once again as outsiders. They don't like that at all. The problem is that the decision whether or not we stay isn't up to us. Then the kids just have to live with it and adjust.

Our children on holiday enjoying games and activities HZI





Our children on holiday enjoying games and activities HZI

What kind of requests do you have as a scientist with a family at a research facility?

Cicin-Sain: The thing that would make it easier for us junior scientists with families would be to present more transparent criteria regarding a conversion to a long-term contract right at the beginning of the initial contract. Then we would know – if I reach these goals within five years, I can stay on. That would raise the level of our quality of life a lot – and that of our children.

Ritter: Or on the other hand, when you're made aware right at the start that a position is definitely only a short-term contract, then you could decide whether you want to get involved or not.

Körner: The issue here is just being able to make definite plans for the future, isn't it?

Ritter: Yes, precisely. When we move we usually move a long ways away. What should we do as a family, how many languages can the children handle, how many changes of school... ?

Cicin-Sain: In the end one would have to conclude that the scientific world is not made for families...

Thank you so much for the discussion!

The interview was performed by Dr. Jo Schilling. Dr. Schilling is a freelance science journalist, writing for national and international newspapers, magazines and radio stations. She is specialized in biotechnological, medical and chemical topics.

Research Climate and Atmosphere at HZI

The HZI offers excellent research conditions for both established scientists as well as junior talents. Embedded in the structures of the Helmholtz Association, researchers here find individual solutions for their very different requirements regarding the scientific environment. Interdisciplinary work, outstanding infrastructure, and a vibrant scientific community characterize the research at the HZI.



E. Medina

The HZI draws together a range of highly skilled scientists across different disciplines with the aim of advancing knowledge on infectious diseases. Our research centre provides significant opportunities for scientists to pursue excellent research through an extensive array of state-of-art facilities and by strongly encouraging collaborative work. Furthermore, the HZI fosters cross-cultural understanding through its international atmosphere. (Medina)

Our strength is the diverse know-how concentrated in one Centre and the great willingness of its people to communicate and collaborate. One example from my research field: scientists at “Microbial Natural Products” in Saarbrücken discovered the new myxobacterial genus *Aetherobacter*. Fermentation of the novel strains was optimised at “Microbial Drugs” in Braunschweig. Joint efforts of both research groups yielded the aetheramides, an unprecedented class of natural products. Scientists at “Chemical Biology” soon found potent anti-HIV activity of aetheramides and identified their mode of action. Chemists at “Medicinal Chemistry” are now working on their total synthesis and optimization. TWINCORE is involved in their evaluation as therapeutic agent for the clinics. (Sasse/Stadler)



F. Sasse



M. Stadler

Quantification of protein expression using an imaging system that detects chemiluminescence. Dr. Frida Ewald and Prof. Dr. Ingo Schmitz discuss results from an RNA interference experiment. HZI/Hallbauer & Fioretti

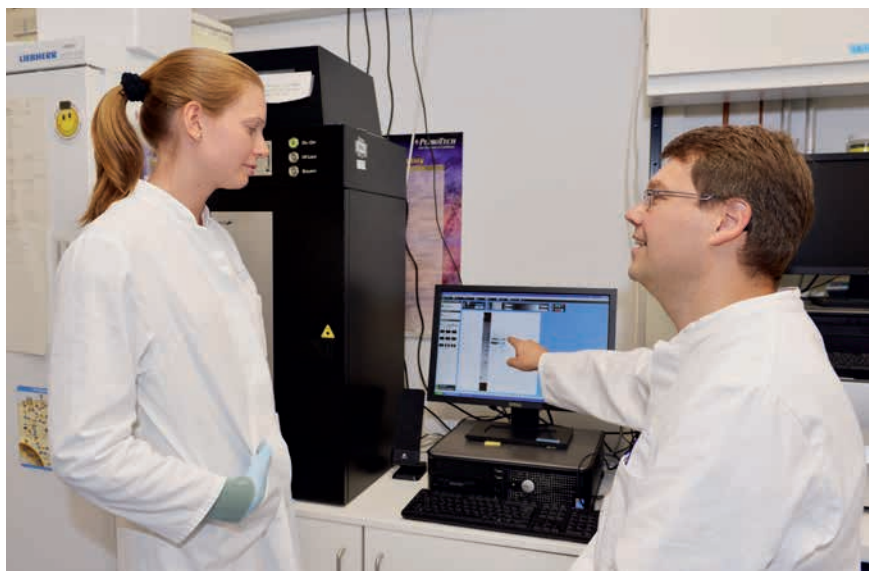

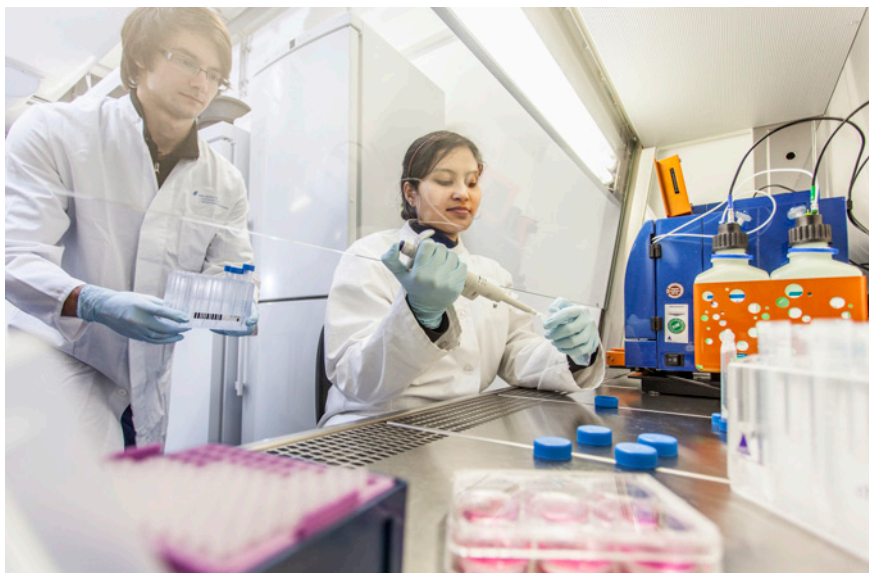

Working at a cleanbench HZI | T. Steuer

The research projects in our department aim to understand the genetic factors that influence the host response to influenza A virus infections. For these studies we are collecting large data sets from mouse populations and mutants. Some of the mouse strains are wild-derived and very difficult to handle. The HZI is the ideal research centre to perform such studies because it has excellent animal facilities, including BSL3 laboratories, very dedicated and expert animal care takers, together with excellent genomics and transcriptomics platforms. (Schughart)



K. Schughart

The Helmholtz Association has a strong commitment towards the fostering of young researchers, which offers unique opportunities to junior scientists, like myself. HZI offers me ideal conditions in terms of my scientific independence, but also strong support where needed. I benefit greatly from the available technological platforms, from the administrative support in third party funding, IP rights management and graduate school programmes, but also from interactions with scientists at HZI and at partner universities. (Cicin-Sain)



L. Cicin-Sain

The HZI offers state-of-the-art enabling technologies such as transcriptomics, proteomics, a cell sorting facility, bio-safety level 2 and 3 laboratories and one of the most sophisticated animal facilities in Europe. This together with a stimulating and collaborative atmosphere and a very well organized programme for the scientific education of PhD students establishes an excellent scientific environment for immunologists and makes it an attractive place for researchers interested in infection immunology. (Bruder)



D. Bruder

On the Living Conditions in the Braunschweig-Wolfenbüttel Region

Even Scientists finish work and have a life outside of the laboratory. For this leisure-time the region of Braunschweig-Wolfenbüttel offers various incentives - both for a well-organized family life as well as for inspiring recreational activities in culture or nature. As the second largest city in Lower Saxony and an important location for science and research, Braunschweig has developed a broad range of cultural activities.



R. Jonas

It is really worthwhile to live in the Braunschweig-Wolfenbüttel region. For families you can find very good conditions with regard to kindergarten and schools, especially a broad variety of excellent high schools. The cultural offerings include – good theatres (from opera to new stage plays), a symphony orchestra, music schools and many good sports clubs. A special thing is the Domsingschule (the biggest institution for Protestant church music in Germany) and the contributions that the churches give to cultural life in both cities, including an intensive oecumenical work. Both cities are historically interesting. (Jonas)



S. Richter

Braunschweig's population is around 244,000 people. Braunschweig is a very attractive city to live in because it is a city with a lot of opportunities. The advantages of Braunschweig from my point of view: It is attractive for the families with young children. It is a very green city with a lot of parks. There are some public swimming pools. Here we have a good situation with enough places in kindergarten and day care and enough play areas for children. (Richter)



The Braunschweig Cathedral (Braunschweiger Dom) Stadt Braunschweig / Gisela Rothe



Relaxing leisure time for families at Okercabana in the Bürgerpark Braunschweig Braunschweig Stadtmarketing GmbH / David Taylor



The “Zeughaus”, used by the dukes of Wolfenbüttel-Braunschweig as a store house for weapons and other military material, nowadays being part of the Herzog-August-Library of Wolfenbüttel R. Jonas



Visit at the Brocken, the highest mountain (1142m) of the Harz region, as well as in Northern Germany, with the famous Brocken-Bahn (steam train) during winter time R. Jonas



“Little Venice” in the centre of Wolfenbüttel during winter time R. Jonas

Braunschweig has the advantage of short distances: one can be downtown in 15-20 min, it's only a 30 min drive to the Harz Mountains to go hiking or skiing and Berlin can be reached in less than 1.5 hours by train. From the great variety of cultural and sporting activities, Braunschweig offers a yearly highlight, which is a “Culture in the Tent” offering for a whole month a varied program with national and international artists in a unique tent-atmosphere. Pure recreation with a different view on the city is a boat trip on the river Oker, which with its parks form a green circle around the inner city. (Kügler-Walkemeyer)



C. Kügler-Walkemeyer

Living on the city boundary, with a short distance to the HZI to the south and the city centre to the north, for me personally, Braunschweig combines the advantages of a large city with the ones of the countryside. The city of Braunschweig offers all necessary city administration as well as a large number of cultural and historical attractions. In addition, with its large green areas and city parks, Braunschweig is ideal for recreation and spare time activities after work. In my view, with these characteristics, the Braunschweig/Wolfenbüttel area is offering very good living and working conditions. (Scrima)



A. Scrima

What makes living in the Braunschweig area so nice? I like the pre Harz hills around Braunschweig so much. Cycling over Elm, Asse or Rieseberg is so fantastic. This region is called “Tuscany of the North” and you can see and feel this when cycling in spring or summer through the region between Elm and Asse. To the south and alongside the mighty Oderwald hills a cyclist can reach the Harz Mountains and also return in one day. So this region is great for cycling and this is one of my favorite leisure activities. (Plähn)



A. Plähn



Authors

Dr. Birgit Manno

Editor, Department of Public Relations (ÖA)
birgit.manno@helmholtz-hzi.de



Manfred Braun

Head of Department of Public Relations (ÖA)
mbn@helmholtz-hzi.de

Highlights 2012 / 2013

Science for the Public

The great epidemics – a lecture series for the public

In autumn 2012, the HZI took interested visitors on a journey through time: On the occasion of a lecture series organised by the HZI together with the DZIF, different speakers highlighted the great epidemics of the plague, tuberculosis, influenza and AIDS from different perspectives. Scientific historians presented the impact of these diseases in history while physicians explained how we handle them today. How diagnosis, therapy and prevention will develop and hence what role epidemics will have in the future was illustrated by scientists. The format of the event was well accepted by the public with lively question and answer sessions following the presentations.

A lecture series about the great epidemics attracted many visitors. On the photo: Manfred Braun, Priv.-Doz. Dr. Gottfried Wilharm (Robert Koch Institute, Wernigerode), Prof. Dr. Karl-Heinz Leven (University Erlangen-Nürnberg) and Dr. Julia Riehm (Institute for Microbiology of the Bundeswehr) (from left to right) are answering questions and remarks from the audience.

HZI/Hallbauer & Fioretti



Photography Competition “INFEKTIÖS”

How can photography as a medium be used to communicate scientific content? Together with the Haus der Wissenschaft, the HZI had announced the photography competition INFEKTIÖS to answer this question. The winning pictures were shown in the Haus der Wissenschaft and will go on tour to different sites.



Dr. Eric Pawlitzky was awarded the first prize for his photo series on a self-help group of AIDS widows in Nyabondo. From left to right: Annegret Ihbe (Vice Mayor of Braunschweig), Prof. Dirk Heinz (Scientific Director of the HZI), Dr. Eric Pawlitzky und Dr. Karen Minna Oltersdorf (Director of the Haus der Wissenschaft) Florian Koch

School lab BioS celebrated its 10th anniversary

Ten years of experiments for pupils, ten years of advanced training for teachers and those that study to become teachers, ten years during which the BioS acted as a bridge between schools and research. Participating young people can catch first insights into research and get to know science on the HZI research campus, which may create interest for their future career choice. The anniversary was celebrated in June 2012 at HZI with guests from politics and science and with school representatives.



The School lab BioS invites pupils to get first insights into research. HZI/Gramann

Science for the small ones – a special kind of school teaching

HZI started cooperation with the local primary school giving fourth graders the possibility to gain a first experience of what research is like. PhD students of the institute visited school classes and supervised a two-day microbiological experiment. Equipped with lab coats, the children enthusiastically analysed how many bacteria live on their hands – before and after washing. The experiment was designed by the BioS school lab and will be continued in the following years.



Junior researchers at work. HZI/Grabowski

Prizes and Awards

Life-saving plastic bags

Some serious illnesses may be treated using the body's own stem cells. One obstacle, however, is contamination occurring during stem cells handling. A sophisticated solution to this confinement comes from scientists of the Helmholtz Centre for Infection Research (HZI), the Fraunhofer Institute for Surface Engineering and Thin Films (IST) and the Braunschweig Medical Centre: They developed a plasma-coated plastic bag that allows sterile cultivation of the stem cells. For this innovation, the HZI scientists Dr. Kurt Dittmar and Dr. Werner Lindenmaier, together with their colleagues, were honoured with the prize "Technik für den Menschen" of the Fraunhofer-Gesellschaft in June 2013.

From left to right: Dr. Henk Garritsen (Braunschweig Medical Centre), Dr. Werner Lindenmaier (HZI), Dr. Michael Thomas (IST), Dr. Kristina Lachmann (IST) und Dr. Kurt Dittmar (HZI).

© Fraunhofer/Dirk Mahler

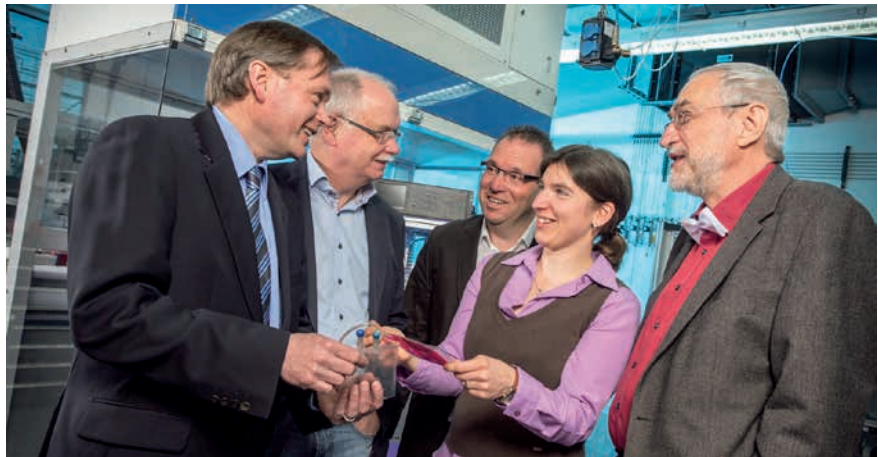

Prof. Dirk Heinz (Scientific Director of the HZI, left) and Prof. Christopher Baum (MHH President, right) with the new Humboldt-Professor Emmanuelle Charpentier.

MHH/Kaiser



Prestigious award for HZI researcher

Prof. Emmanuelle Charpentier, head of the Department "Regulation in Infection Biology", is one of the recipients of the 5 million Euro Alexander von Humboldt Professorship, one of Germany's most highly coveted research awards. The

French microbiologist conducts research at the HZI and teaches at the Hannover Medical School (MHH). Charpentier is particularly interested in determining how RNA and proteins interact to regulate gene activity. She has co-discovered a rudimentary bacterial "immune system," which helps microorganisms defend themselves against viruses. The Humboldt Professorship serves the goal of making Germany internationally competitive as a scientific research hub – Charpentier's recent switch to Braunschweig-Hannover definitely is a major win for the national research landscape. The award ceremony will take place in 2014.

Inhoffen Awards for Peter Leadlay and Christopher T. Walsh

In 2012, the Inhoffen Medal, one of the most prestigious German prizes in the field of natural compound chemistry, was awarded to Prof. Peter Leadlay, University of Cambridge. He was honoured for his pioneering work in deciphering the genetic code of the molecular assembly line that produces so-called polyketides. Some of these secondary metabolites have antibiotic properties. Today, Leadlay's research allows us to manipulate the bacterial production system and obtain optimised compounds.

US biochemist Prof. Christopher Walsh, awardee of the Inhoffen Medal in 2013, focused on these bacterial "factories" as well. Much of his research has been concerned with the investigation of the structure and function of enzymes, cellular catalysts that play major roles in the assembly lines, to better understand their molecular basis. The Inhoffen Medal is funded by the Friends of the HZI and awarded in memory of Prof. Hans Herloff Inhoffen, founder of the HZI's predecessor institute, the Institute of Molecular Biology, Biochemistry and Biophysics.



Bestowal of the Inhoffen Medal 2012. From left to right: Prof. Dirk Heinz (HZI), Prof. Peter Leadlay (University of Cambridge), Prof. Joachim Klein (Friends of the HZI), and Prof. Martin Korte (TU Braunschweig) HZI



In 2013, Prof. Christopher Walsh was awarded the Inhoffen Medal. From left to right: Prof. Dieter Jahn (TU Braunschweig), Prof. Rolf Müller (Helmholtz-Institute for Pharmaceutical Research Saarland), Prof. Christopher Walsh (Harvard Medical School), Prof. Dirk Heinz (HZI), and Prof. Dietmar Schomburg (Friends of the HZI) HZI/Hallbauer & Fioretti

Further prizes and awards



Professor Claus-Michael Lehr, head of the Department Drug Delivery at the Helmholtz-Institute for Pharmaceutical Research Saarland (HIPS), and his colleagues Dr. Eva-Maria Collnot and Fransisca Leonard shared with a further awardee the animal welfare research prize of the Federal Ministry of Food, Agriculture and Consumer Protection in December 2011. From left to right: Parliamentary State Secretary Peter Bleser, Fransisca Leonard, Dr. Eva-Maria Collnot, Prof. Claus-Michael Lehr, Dr. Jörn Hendrik Reuter and Prof. Andreas Hensel, President of the Federal Institute for Risk Assessment Bundesinstitut für Risikobewertung

Further prizes and awards



For his outstanding services to the Indo-German scientific cooperation, Prof. Singh Chhatwal, head of the department "Medical Microbiology" at HZI, received the highest honour conferred on overseas Indians, the Pravasi Bharatiya Samman Award in January 2013. *HZI*



Prof. Rolf Müller, Managing Director of the Helmholtz-Institute for Pharmaceutical Research Saarland (HIPS), has been elected member of acatech, the National Academy of Science and Engineering *Kegler*



The European Research Council (ERC) supports Dr. Andriy Luzhetskyy, head of a junior research group at the Helmholtz-Institute for Pharmaceutical Research Saarland (HIPS), with an ERC Starting Grant endowed with 1.5 million Euros

Mario Rembold

Scientific Events

Third „North-Regio-Day on Infection“ (NoRDI) at the HZI

Established in 2010, NoRDI has become a central event for scientists from universities and research institutes of Northern Germany. In August 2012, the English language symposium took place for the third time and attracted much interest. Especially young scientists took the chance to discuss their research with established experts of the field. In the context of NoRDI, the Jürgen Wehland Prize is awarded in remembrance of the former Scientific Director of the HZI, Prof. Jürgen Wehland. It acknowledges excellent young scientists with a research focus on infection biology – in 2012, Dr. Stephanie Bertram of the German Primate Centre for her outstanding research on influenza viruses.

Stefan Pöhlmann, head of the Department of Infection Biology at the German Primate Center, accepted the award in place of the laureate. From left to right: Prof. Dirk Heinz, Scientific Director of the HZI, Prof. Stefan Pöhlmann and the laudator Prof. Stephan Becker. *HZI/Gramann*



4th TWINCORE Symposium

In September 2012, the TWINCORE Centre for Experimental and Clinical Infection Research attracted interested researchers and renowned guest speakers such as Michel Nussenzweig, Harald von Boehmer and Klaus Rajewsky for the 4th TWINCORE Symposium. The focus of the meeting was on advanced animal models in the field of infection research and immunology. In particular, participants discussed herpes viruses, hepatitis viruses, vaccination, tolerance, humanized mice and host defense.



Dr. Alexander Ploss, Rockefeller University, was one of the speakers of the 4th TWINCORE symposium. TWINCORE

The HZI – Nationally and Globally Connected

Joint focus on infectious diseases and epidemiology

Bacterial antibiotic resistance, vaccine development and new insights into the epidemiology and ecology of pathogenic bacteria – these are topics that the HZI and the Robert Koch Institute (RKI) will approach together. Since December 2012, the two institutes are sharing their resources and potential to find answers to urgent questions of infection research and epidemiology. An according agreement was signed by Prof. Dirk Heinz, Scientific Director of the HZI, and RKI's president Prof. Reinhard Burger.



Prof. Dirk Heinz (HZI, left) and Prof. Reinhard Burger (RKI, right) after signing the cooperation agreement. HZI

A North German centre to investigate microbial genomes

The bacterium *Clostridium difficile* is an opportunistic pathogen. To find out which genes and proteins exactly make it so dangerous for humans is the first joint project of the newly established “Norddeutsches Zentrum für Mikrobielle Genomforschung” (NZMG). Its aim is to carry out research on microbial genomes together and address highly relevant acute questions in one of the most important fields of today's life sciences. The centre will link the research infrastructures of the HZI, the Universities of Göttingen and Greifswald, the Hannover Medical School, the Technische Universität Braunschweig and the Leibniz Institute DSMZ-German Collection of Microorganisms and Cell Cultures. It was officially inaugurated in January 2013.



The founding members of the NZMG at the inauguration ceremony. Georg August University Göttingen

A German-Argentine immunology network

In Argentina, where infectious diseases such as tuberculosis and HIV are an important issue, an active science community is forming. In the future, joint research projects with Germany as well as the exchange of students and teaching staff will be part of it. A memorandum of understanding on this bi-national collaboration was signed in March 2013 by representatives of the HZI, the Hannover Medical School and the University of Buenos Aires in Argentina. The initiator Prof. Tim Sparwasser, Director of the Institute of Infection Immunology at the Twincore, will coordinate the agreement from the side of the MHH and the HZI.

Prof. Ulrich Kalinke (5th from left) and Prof. Tim Sparwasser (2nd from right) met German politicians and Argentine scientists in the German embassy in Buenos Aires.

Tim Sparwasser



Helmholtz International Fellow Prof. Lorne A. Babiuk. University of Alberta

Transatlantic cooperation against infectious diseases

Working together on topics like hepatitis is one aspect of the Helmholtz Alberta Initiative, a research partnership between the Helmholtz Association and the University of Alberta, Canada. The collaboration between the HZI and the Canadian university was reinforced in January 2013 with the appointment of the vaccine researcher Prof. Lorne A. Babiuk as “Helmholtz International Fellow”. The vice president of the University of Alberta had been nominated by the HZI.

Joint research on zoonotic streptococci with the Chinese Academy of Sciences (CAS)

Zoonotic streptococci cause serious diseases such as septicaemia and meningitis in humans but have to date not received sufficient scientific attention. Scientists from different fields such as veterinary medicine, host-pathogen interaction, epidemiology and genomics will now investigate these pathogens in a joint research group of the HZI, represented by Prof. Singh Chhatwal, the University of Veterinary Medicine Hannover (TiHo), and the Chinese Academy of Sciences in Beijing. A respective application of the HZI and the CAS was approved and will enhance German-Chinese cooperation.

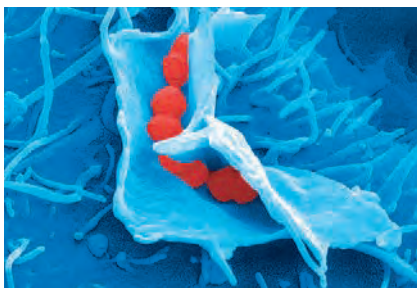

Within the joint research group, Prof. Singh Chhatwal and his team will study interactions between zoonotic streptococci and their hosts. HZI/Rohde

New Buildings, new Possibilities

Research at biosafety level 3

The newly built S3 laboratory was commissioned in March 2013. It is equipped for working at biosafety level 3. The new facility allows investigating agents that may cause serious or potentially lethal disease in humans such as the avian flu virus or the tick-borne encephalitis virus. Safety equipment and laboratory facilities as well as lab techniques are in compliance with regulations and enable scientists to study some of the most serious diseases.

Breaking ground for BRICS in 2013/2014

How do complex biological systems like cells or organs behave as a whole? This is what scientists in the Braunschweig Integrated Centre for Systems Biology (BRICS) will investigate with the help of the “-omics” technologies. Research groups focusing on genomics, proteomics and systems immunology will be part of the interdisciplinary centre. BRICS will have two sites—at the Technische Universität Braunschweig as well as on the HZI campus. Start of construction is expected to be 2013 and 2014, respectively.



Dr. Susanne Talay, responsible for operating the S3 laboratory, demonstrates working in a protective gear. HZI/C. Talay



A visualisation of the BRICS site on the HZI campus. ASSMANN Beraten und Planen

Prizewinning architecture at HZI

“Technoid, but still pragmatic” – this is how the jury of an architectural competition described the appearance of the new building of the HZI animal facility. The Lower Saxon Association of the “Bund Deutscher Architekten” honoured the HZI and the responsible architect’s office doranth post architekten GmbH during a ceremony in the state parliament of Lower Saxony in June 2012.



The animal facility – awarded for its architecture. HZI/Schughart



Author

Prof. Dr. Dirk Heinz

Scientific Director

dirk.heinz@helmholtz-hzi.de

New Junior Research Groups

For the HZI, the recruitment of excellent junior research group leaders with international experience is an integral part of its research strategy. Their scientific and methodological expertise complements and strengthens the centre's research portfolio. Being highly motivated young investigators and supervisors they also contribute to the stimulating atmosphere on campus. In the following section, five new Junior Research Group leaders who have recently joined the HZI will briefly introduce their research:

Dr. Andrea Scrima, head of the junior research group “Structural Biology of Autophagy” at the HZI in Braunschweig, was recruited from the Friedrich Miescher Institute for Biomedical Research in Basel, Switzerland, in 2011 and investigates the role of autophagy in immunity and infectious diseases.

Dr. Andriy Luzhetskyy, who was recruited from the University of Freiburg, has been heading the junior research group “Actinobacteria Metabolic Engineering” at the HIPS in Saarbrücken since 2011; his team is committed to exploring the biosynthetic potential of actinobacteria for the development of novel anti-infective drugs.

Dr. Marc Erhardt, who started his junior research group “Infection Biology of Salmonella” at the HZI in 2013, came from the Université de Fribourg, Switzerland; he addresses the molecular mechanisms of Salmonella virulence.

Dr. Till Strowig, who was recruited from Yale University, USA, joined the HZI early in the summer of 2013 to start his junior research group “Microbial Immune Regulation”; he will investigate the role of host's microbiota in infections.

Dr. Alexander Titz from the University of Konstanz set up his junior research group “Chemical Biology of Carbohydrates” at the HIPS in summer 2013; with his research he aims to contribute to the development of innovative anti-adhesion therapeutics for chronic biofilm infections.

All of the young researchers have previously been successful in the competitive selection procedure for the Helmholtz Young Investigators Groups. With this successful career development tool the Helmholtz Association fosters the early academic independence of young researchers. With generous funding shared by the Helmholtz Initiative and Networking Fund and the HZI for at least 5 years, the young researchers get the chance to set up and lead their own research group for a period of five years; an in-built tenure option offers a long-term career perspective at the centre. Each independent junior research group is affiliated with an established HZI department and is fully integrated into the research environment of the centre, giving the group leaders access to excellent infrastructures and allowing them to benefit from advice on scientific projects as well as guidance on career planning by more experienced colleagues. Thanks to close cooperation with our university partners, they gain teaching experience and are able to acquire additional qualifications (like the habilitation or joint professorships) useful for a career in academia.

When some of the junior research group leaders, after successful years at the centre, eventually leave the HZI to continue their careers in prominent positions at other research institutions or universities – such as, in the past two years, Prof. Lars Zender, now Professor at the University of Tübingen, and Dr. Maximiliano Gutierrez, now Programme Leader Track at the National Institute for Medical Research, UK- they will become part of an ever increasing HZI alumni network that provides long-lasting personal links to the best infection research institutions in Germany and abroad.



Project Leader

Dr. Andrea Scrima

Junior Research Group Structural Biology of
Autophagy (SBAU)

andrea.scrima@helmholtz-hzi.de

Structural Biology of Autophagy in Infection and Disease

The origins of autophagy

The term “Autophagy” is derived from the Greek words “auto” and “phagein”, literally meaning “self-eating”. Christian de Duve (who was awarded the Nobel Prize in 1974 for the discovery of lysosomes) introduced the word “Autophagy” in 1963, at the same time when he coined the words “Endocytosis” and “Exocytosis”. With “Autophagy” he described a cellular process observed by electron-microscopy studies in which single and double membrane structures with intracellular particles, including organelles, at different degradation stages were detected. In the following decades, the different degradation stages were characterized in further detail and regulatory autophagy-genes and the family of ATG-proteins, comprising more than 30 proteins, were discovered. This initiated the characterization of autophagy on the molecular level (reviewed in Klionsky, 2008).

Fig. 1. Overview of membrane dynamics in the autophagy pathway. Abbreviations: ER, endoplasmic reticulum; N, nucleus.

Mizushima et al., 2011 (modified)

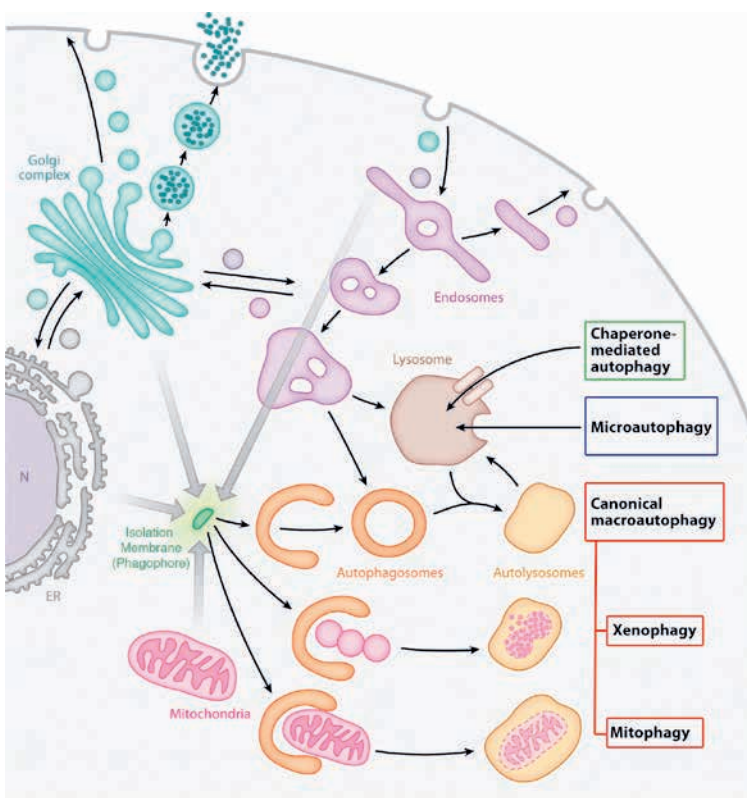

Autophagy today

With the further knowledge gained over time, autophagy can now be described as a cellular process that is dedicated to the degradation of intracellular components. Three major degradation pathways in autophagy are known, which include i) chaperone-mediated autophagy (direct transport of cellular components across the lysosomal membrane), ii) microautophagy (direct engulfment by invagination of the lysosomal membrane) and iii) canonical macroautophagy, hereafter referred to as autophagy. Various triggers can activate autophagy leading to the formation of the isolation membrane, also called phagophore, which expands and forms the autophagosome. These autophagosomes are specialized double membrane structures that sequester cytoplasmic components and subsequently fuse with lysosomes, resulting in degradation of the engulfed cargo, such as proteins and organelles (Figs. 1, 2). While initially identified

as starvation-induced process for maintenance of homeostasis by unspecific, bulk degradation of intracellular components and recycling of the degradation product, the number of newly discovered specific autophagy-mediated degradation events is increasing (reviewed in Mizushima et al., 2011).



Project Members

Archana, Milica Bajagic, Stefan Leupold, Dr. Stefan Schmelz, Dr. Andrea Scrima

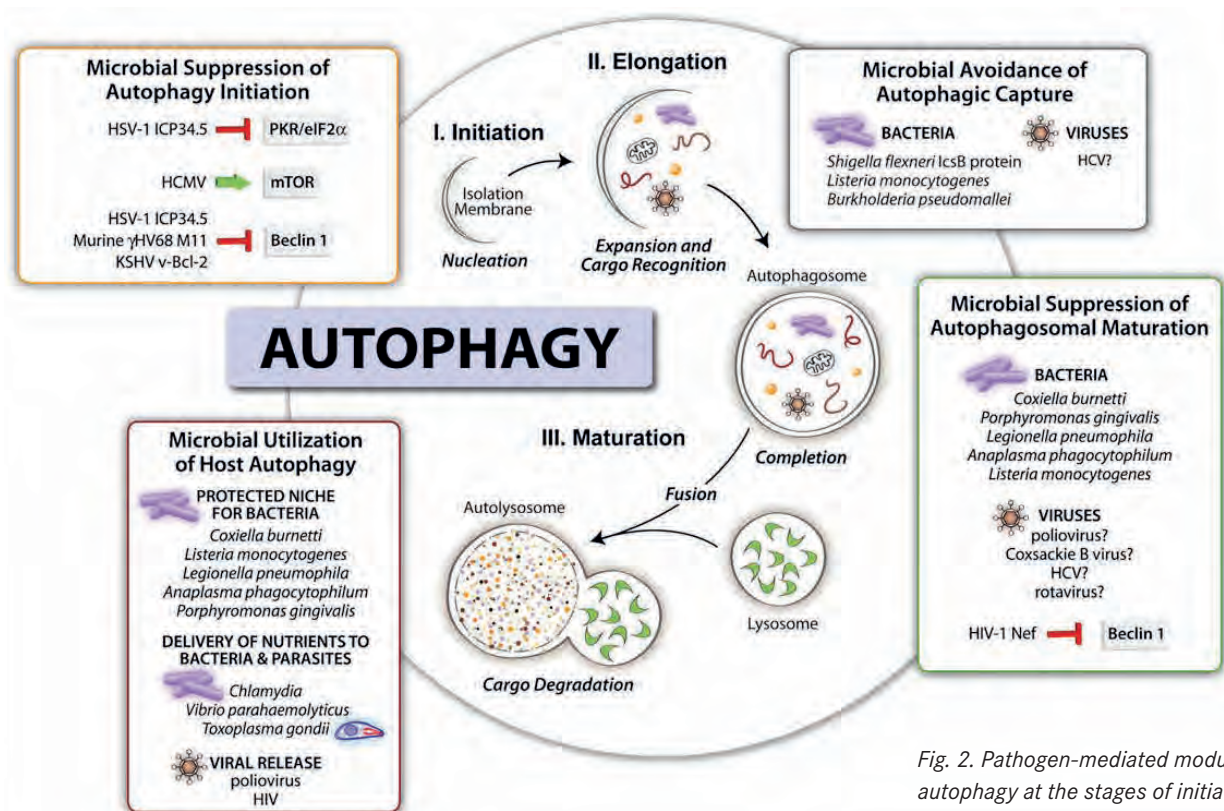

Fig. 2. Pathogen-mediated modulation of autophagy at the stages of initiation, elongation and maturation Deretic and Levine, 2009

Autophagy in immunity and disease

Apart from the degradation of defective mitochondria, *via* a process termed “Mitophagy”, autophagy is involved in a large number of immunity-related processes in mammalian cells, such as thymic selection, antigen presentation, lymphocyte homeostasis and regulation of inflammatory responses (reviewed in Levine et al., 2011). The importance of autophagy is also reflected in the finding that defects in autophagy can lead to the onset of cancer, neurodegenerative and chronic inflammatory diseases. The latter include Crohn’s disease (CD), a complex chronic inflammatory disease of the intestine that causes lesions in the intestinal tract with an increased risk of colon cancer formation. The genetic links between autophagy and CD have recently been uncovered; mutations in the autophagy gene ATG16L1, the gene encoding the autophagy-stimulatory GTPase IRGM as well as mutations in NOD2, an innate immunity intracellular recognition receptor for bacterial components, increase susceptibility to CD

and have been shown to impair autophagy. Despite knowledge of these “risk” alleles, the molecular mechanisms that lead to the onset of Crohn’s disease are to date only poorly understood (reviewed in Klionsky, 2009).

Autophagy: a cellular defense mechanism against pathogens

Autophagy emerged as powerful cellular defense mechanism against various pathogens (bacteria, viruses, parasites) to counteract infections and mediate pathogen clearance by direct engulfment and degradation. In a process termed “Xenophagy”, these pathogens, either free in the cytosol, inside phagosomes or pathogen-containing vacuoles, are targeted and degraded by autophagy. However, the co-evolution of pathogens and the human host has led to the development of sophisticated strategies used by pathogens not only to evade autophagic detection and degradation, but also to exploit autophagy for their own benefit. Bacterial pathogens, such as *Shigella flexneri*, *Listeria monocytogenes* and *Staphylococcus aureus*, as well as viral pathogens including herpesviruses, human immunodeficiency virus-1, influenza A virus and Hepatitis C virus have evolved a set of tools to modulate autophagy at various stages of the degradation pathway (Fig. 2). Herpesviruses block initiation of autophagy at the stage of isolation membrane/phagophore formation by specifically targeting regulatory host autophagy proteins. An alternative strategy for evasion is to avoid recognition and capture by the host autophagy system as used by the intracellular bacterial pathogens *Shigella flexneri* and *Listeria monocytogenes*. In

Fig.3. Structural Biology workflow: Selected target proteins are expressed as recombinant proteins in diverse expression hosts, such as *E. coli*, insect and mammalian cells, and purified to homogeneity by the use of chromatographic methods (1). The next steps consist of the crystallization of the protein (2) and collection of the X-ray diffraction image (3). The data obtained from the X-ray diffraction experiment is used to calculate an electron density map that represents the envelope of the amino acids forming the protein chain (4). The map is subsequently used to build the protein-chain (5) thereby obtaining the structure of the protein of interest at atomic resolution (6) Photos/Layout: Scrima

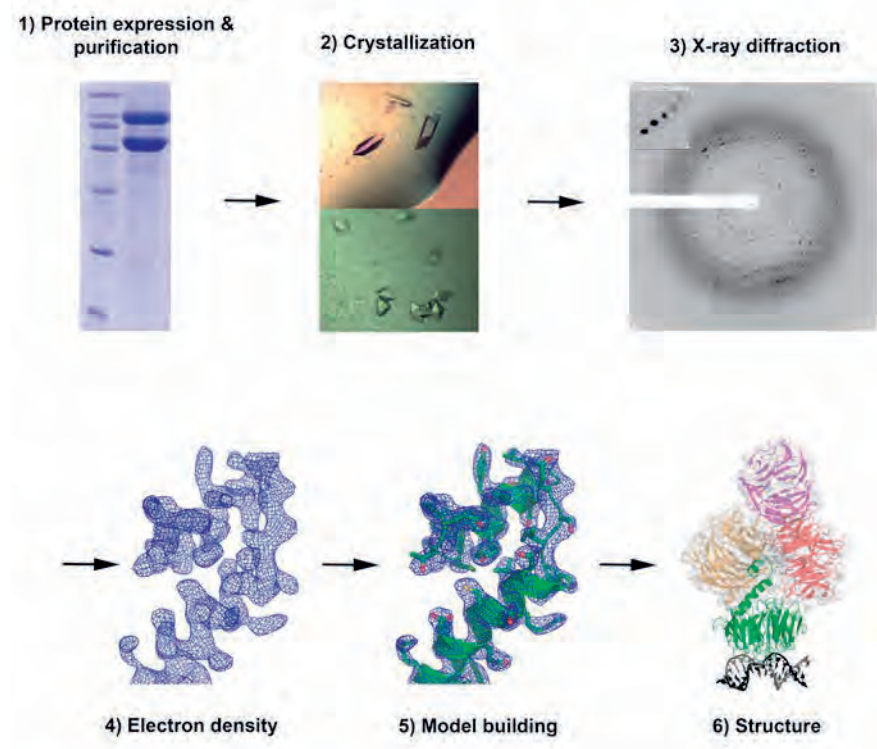

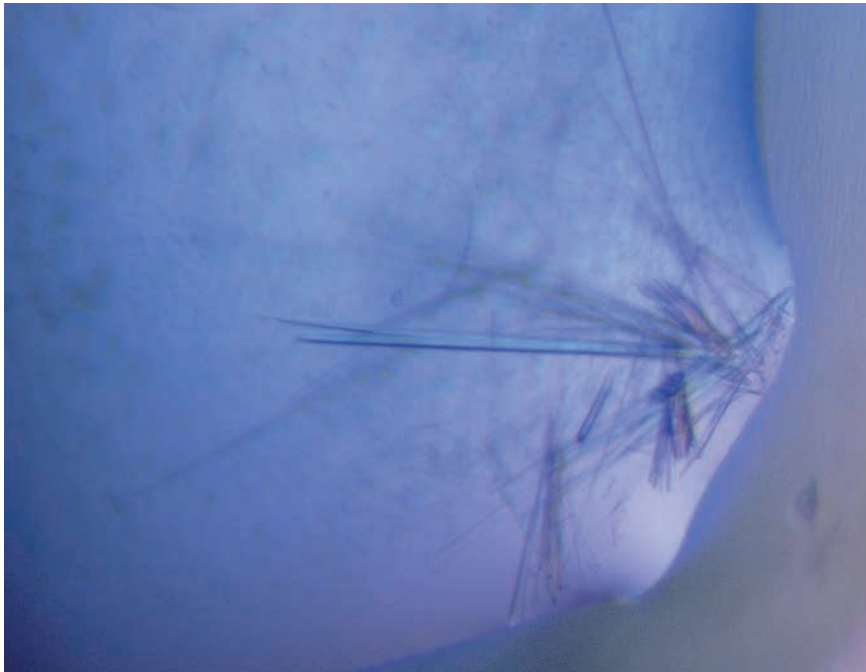

Fig.4. Crystals of a regulatory ATG-protein

Photo: Stefan Leupold

addition, viruses and bacteria impede autophagosomal maturation and fusion with lysosomes to counteract clearance by autophagy. While many strategies aim at blocking autophagy, some bacterial pathogens even activate autophagy in a controlled manner to allow for intracellular survival and the use of autophagosomes as safe replicative niche; several viruses are believed to activate autophagy in order to enhance viral replication and egress to promote infection (reviewed in Deretic and Levine, 2009).

Our research focuses on the characterization of the central mechanisms of autophagy regulation as well as the molecular mechanism of pathogenic evasion. Using X-ray crystallography, complemented with proteomics, biochemical/biophysical and cell biological methods, we want to gain an insight into the function of host- and pathogen-derived proteins in the context of host cell defense by autophagy and immune evasion. The process from protein to structure comprises a number of different steps as depicted in the structural biology workflow (Fig. 3). We are currently expressing, purifying and crystallizing various target host-proteins and proteins from pathogens that modulate autophagy (Fig. 4) for further structural and biochemical characterization.

Perspectives

Despite of the current research on autophagy, the fundamental processes that regulate different stages of autophagy, as well as the strategies pathogens use to evade or exploit autophagy, are not well understood. In addition, the impact of mutations on the function of autophagy-regulating genes, as seen in Crohn's disease, is still elusive at the molecular level. Protein structures of these central

key players in autophagy, pathogenic modulator proteins and their targets in the host will greatly contribute to our knowledge of autophagy regulation and the interplay of host and pathogen in pathogen defense and infection processes. These proteins represent important therapeutic targets since a selective suppression of immune evasion mechanisms might allow us to reactivate the host defense mechanism autophagy and consequently counter the infection. A detailed understanding of autophagy regulation and pathogenic evasion mechanisms at atomic level may thus help to find novel ways of therapies for diseases linked to infection and defects in autophagy.

In summary, we aim at:

- Analyzing regulatory mechanisms in autophagy
- Understanding pathogen detection mechanisms at the molecular level
- Unraveling the structural basis of pathogenic evasion mechanisms
- Utilizing the gained knowledge to counter infections and pathogenic immune evasion processes



Andrea Scrima born in 1977 in Dortmund, Germany, is head of the Junior Research Group Structural Biology of Autophagy at the Helmholtz Centre for Infection Research (HZI). He studied at the Ruhr-University Bochum and obtained a biochemistry degree from the university in 2002. In 2006 he was awarded a PhD for his thesis work on the structure and function of GTPases at the Max-Planck Institute of Molecular Physiology, Dortmund, Germany. Afterwards he spent almost 5 years as postdoctoral scientist at the Friedrich Miescher Institute in Basel, Switzerland, as an EMBO and Ambizione (SNSF) fellow. After his post-doctoral work on UV-damaged DNA recognition in the context of nucleotide excision repair, he joined the HZI in 2011 as head of the Junior Research Group Structural Biology of Autophagy. The main area of research of his group is the structural and functional characterization of regulatory processes in autophagy and of host-pathogen interactions with a focus on autophagy-mediated pathogen defense and pathogen-derived immune evasion mechanisms.

Publications

Shi, T., Bunker, R.D., Mattarocci, S., Ribeyre, C., Faty, M., Gut, H., Scrima, A., Rass, U., Rubin, S.M., Shore, D., & Thomä N.H. (2013) Rif1 and Rif2 Shape Telomere Function and Architecture through Multivalent Rap1 Interactions. *Cell* **153**(6), 1340-1353.

Hofmeyer, T., Schmelz, S., Degiacomi, M.T., Dal Peraro, M., Daneschdar, M., Scrima, A., van den Heuvel, J., Heinz, D.W., & Kolmar H. (2013) Arranged Sevenfold: Structural Insights into the C-Terminal Oligomerization Domain of Human C4b-Binding Protein. *Journal of Molecular Biology* **425**(8), 1302-1317.

Fischer, E.S.*, Scrima, A.*, Böhm, K., Matsumoto, S., Lingaraju, G.M., Faty, M., Yasuda, T., Cavadini, S., Wakasugi, M., Hanaoka, F., Iwai, S., Gut, H., Sugawara, K., & Thomä, N.H. (2011) The molecular basis of CRL4DDB2/CSA ubiquitin ligase architecture, targeting, and activation, *Cell* **147**, 1024-1039 (*equal contribution)

Scrima, A., Fischer, E.S., Lingaraju, G.M., Böhm, K., Cavadini, S., & Thomä, N.H. (2011) Detecting UV-lesions in the genome: The modular CRL4 ubiquitin ligase does it best! *FEBS Letters* **585**, 2818-2825.

Scrima, A., Konícková, R., Czyzewski, B.K., Kawasaki, Y., Jeffrey, P.D., Groisman, R., Nakatani, Y., Iwai, S., Pavletich, N.P., & Thomä N.H. (2008) Structural basis of UV DNA-damage recognition by the DDB1-DDB2 complex. *Cell* **135**(7), 1213-1223.

Meyer, S., Scrima, A., Versées, W., & Wittinghofer, A. (2008) Crystal structures of the conserved tRNA-modifying enzyme GidA: implications for its interaction with MnmE and substrate. *Journal of Molecular Biology* **380**(3), 532-547.

Scrima, A., Thomas, C., Deaconescu, D., & Wittinghofer, A. (2008) The Rap-RapGAP complex: GTP hydrolysis without catalytic glutamine and arginine residues. *EMBO Journal* **27**(7), 1145-1153.

Thomas, C., Fricke, I., Scrima, A., Berken, A., & Wittinghofer, A. (2007) Structural Evidence for a Common Intermediate in Small G Protein-GEF Reactions. *Molecular Cell* **25**(1), 141-149.

Gasper, R., Scrima, A., & Wittinghofer, A. (2006) Structural insights into HypB, a GTP-binding protein that regulates metal binding. *Journal of Biological Chemistry* **281**(37), 27492-27502.

Scrima, A., & Wittinghofer, A. (2006) Dimerisation-dependent GTPase reaction of MnmE: how potassium acts as GTPase-activating element. *EMBO Journal* **25**(12), 2940-2951.

Lammers, M., Rose, R., Scrima, A., & Wittinghofer, A. (2005) The regulation of mDia1 by autoinhibition and its release by Rho*GTP. *EMBO Journal* **24**(23), 4176-4187.

Scrima, A., Vetter, I.R., Armengod, M.E., & Wittinghofer, A. (2005) The structure of the TrmE GTP-binding protein and its implications for tRNA modification. *EMBO Journal* **24**(1), 23-33.

References

Deretic, V., and Levine, B. (2009). Autophagy, immunity, and microbial adaptations. *Cell Host Microbe* **5**, 527-549.

Klionsky, D.J. (2008). Autophagy revisited: a conversation with Christian de Duve. *Autophagy* **4**, 740-743.

Klionsky, D.J. (2009). Crohn's disease, autophagy, and the Paneth cell. *New England Journal of Medicine* **360**, 1785-1786.

Levine, B., Mizushima, N., and Virgin, H.W. (2011). Autophagy in immunity and inflammation. *Nature* **469**, 323-335.

Mizushima, N., Yoshimori T., Ohsumi Y. (2011) The Role of Atg Proteins in Autophagosome Formation. *Annual Review of Cell and Developmental Biology* **27**, 107-132.

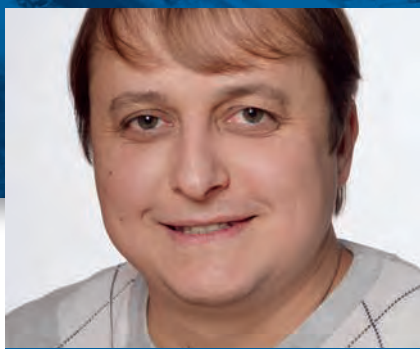

Project Leader

Dr. Andriy Luzhetskyy

Junior Research Group Actinobacteria
Metabolic Engineering, HIPS (AMEG)
andriy.luzhetskyy@helmholtz-hzi.de

Actinobacteria Biosynthetic Potential

For a long time actinobacteria and streptomycetes in particular were considered as an important source of natural products, but nevertheless in last years interest in them reduced as a consequence of a decrease of new antibiotics of actinomycetal origin introduced into the market. It was even regarded that actinomycetes are exhausted sources of natural products; however, results of sequencing data give completely opposite evidence. Genomes of streptomycetes contain huge underexplored potential to produce secondary metabolites. Most genomes contain more than twenty gene clusters responsible for production of secondary metabolites with only few being active and explored. One of the most important current tasks of streptomycetes genetics is to unveil their full potential as a source of new biologically active compounds.

Since most streptomycetes species are rather difficult to manipulate genetically, the easiest and the most common way to discover products encoded by “sleeping” cryptic secondary metabolite gene clusters is to express them in a heterologous host. Such a host usually has a well-developed system for genetic manipulations that allow to easily engineer and tune newly introduced biosynthetic pathways. Among all streptomycetes strains used as a heterologous host so far, *Streptomyces albus* J1074 seems to be one of the best and most widely used.

Host optimization

One of the major interests which we are following is optimization of *S. albus* as a heterologous host for the production of diverse secondary metabolites of actinomycetal origin. In our understanding, host optimization process requires resolution of three main tasks: deletion of all secondary metabolite clusters, overall genome minimization and its metabolic engineering to meet all requirements for overproduction of target heterologous compounds. As already mentioned, actinomycetes contain numerous secondary metabolite pathways encoded in their genomes and *S. albus* is not an exception. Their presence is a serious drawback of a heterologous host since they consume cellular metabolites, which could be and should be directed for the production of target compound. Furthermore, production of “native” compounds can complicate detection and purification of heterologous compounds. Except gene clusters for the production of natural products genome of *S. albus* contain a lot of genetic information which is not necessary for survival in laboratory conditions. As it was already shown in *E. coli*, the deletion of unnecessary DNA regions (genome minimization) often improves the properties of the engineered strain like



Project Members

Bohdan Bilyk, Oksana Bilyk, Dr. Elke Brötz, Dr. Lilya Horbal, Dr. Andriy Luzhetskyy, Niko Manderscheid, Dr. Maksym Myronovskiy, Dr. Yuriy Re-bets, Dr. Bogdan Tokovenko

genetic stability, frequencies of DNA transformation, growth rate, etc. Several examples of positive effects of large DNA deletions in streptomycetes are also known. Thus partially minimized *S. coelicolor* and *S. avermitilis* strains displayed higher levels of production of heterologous compounds. Genome minimization of *S. albus* requires many consecutive manipulations with large DNA fragments. Such a task is almost impossible to accomplish using traditional genome engineering approaches. Here we use our “in-house”-developed technology for the DNA manipulations in actinomycetes exploiting recombinogenic engineering (FLP-FRT, Cre-loxP, Dre-rox, Tn5, Himar1 and I-SceI systems). The main advantage of utilization of site-specific recombinases is their ability to recognize short cognate DNA sequences (binding sites) and to perform precise and effective recombination between them, no matter how distantly they are located. For example, by inserting binding sites for certain recombinase on the borders of a large DNA fragment, it will be deleted or inverted (depending on site’s orientation) after expression of cognate recombinase.

One of the major features of a chassis-strain for the expression of natural product biosynthetic pathways is high levels of target compound production. On the way to reach high productivity a problem of limited precursors has to be solved. Mainly we focus on optimization of *S. albus* for the production of polyketide and terpene antibiotics that use acetyl-, malonyl-CoA and isopentenyl pyrophosphate that is also derived from acetyl-CoA respectively. In order to reach this goal we establish metabolite network of *S. albus* to predict which metabolic reactions should be blocked or down-regulated to redirect metabolite flow in the way to accumulate natural product precursors. Such changes in metabolism of *S. albus* are being introduced by gene inactivation and tuning of their expression level using “in-house”-developed site-specific recombinase tools as well as synthetic biobricks (promoters, ribosome binding sites, terminators).

Standard biological parts for actinobacteria

Alias, ease of engineering and tuning the introduced biosynthetic pathways does not come naturally. At the very least, controlling gene expression requires the use of proper promoters, ribosome binding sites, and terminators. This is where the design and construction of standardized, modular biobrick libraries helps minimizing routine efforts. However, biobricks construction is a challenging task by itself.

Gene expression in bacteria is mainly controlled at the transcriptional level, and, therefore, the promoter is the most efficient tunable element. Simply collecting the strongest promoters will not help though: one needs the entire range of promoter strengths to fine-tune cluster expression (for example, because of the toxicity of some essential compound components). Usually, promoter library construction methods rely on random modification of existing promoters in spacer regions between the consensus sequences and then measuring strength of the resulting promoters. Thus, the proper (sensitive, reliable, easy to use) reporter gene system becomes an important pre-requisite and we had already

Fig.1. Schematic overview of the constructing procedure for the “actinobricks” library (promoter in this case). Degenerated promoter sequence included in the reverse primer marked in red colour. N stands for any of the four nucleotides. PCR product after amplifying the hygromycin resistance conferring gene (*hygR*) contains the synthetic promoter sequence (red). In the final plasmid the synthetic promoter drives the expression of the *gusA* reporter gene. *aadA* - spectinomycin resistance conferring gene flanked by the terminators, *attP* - phage attachment site for integration, *int* - integrase gene. The activity of *GusA* enzymes, reflecting the strength of the synthetic promoter is measured on the spectrophotometer. Figure: Luzhetskyy

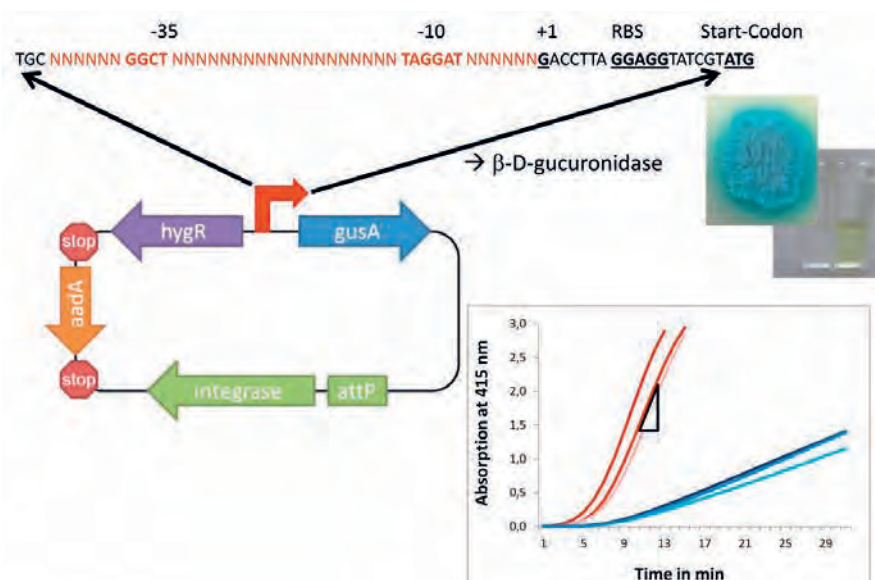

tackled that problem using the synthetic β -glucuronidase gene (GUS). We had also constructed a versatile synthetic 60-promoter library (Fig.1). With the help of RNA-sequencing data we were able to confirm that our GUS reporter system is not affected by translation-level gene expression variations.

Another important component is the RBS, which controls the rate of translation initiation from our target transcript. Fortunately, computational tools had already been developed for tuning the RBS sequence to the desired initiation rate. However, successful application of computational RBS design demands a high-quality genome assembly and annotation (including the 16S RNA, which confers strain specificity for initiation rate tuning).

The two briefly described biobricks are the examples of success while they also represent the most basic levels of control. For achieving that success, we had already employed genome sequencing, assembly and annotation, as well as RNA-sequencing. Higher-level biobricks (inducible promoters, tunable intergenic regions, entire biosynthetic mini-clusters, regulatory feedback loop constructs, gene expression switches with memory independence from the presence of the switching compound), as well as metabolic-level tuning, will require additional methods, such as genome-wide inference of gene regulatory and metabolic networks, experimental (stable-isotope) and computational flux analysis, yield optimization, etc. Despite the obvious complexity, we believe in the utmost importance of pushing forward the development of biobricks to fully exploit the biosynthetic potential of actinobacteria.

Regulatory network targeting

All afore mentioned approaches are based on the deep understanding of genetics, biochemistry and molecular biology of the target strains. However, a lot of

genes involved in control of secondary metabolism remain unknown. Streptomycete's genomes usually contain a significant number of genes involved in transcriptional regulation. The currently known regulatory network controlling secondary metabolism covers only some part of them, while function of the rest remains unclear. Development of effective streptomycetes host requires a deep understanding of regulatory network controlling secondary metabolism genes expression that is impossible without identification of all major players of these processes. The indispensable tool for this task is the system of random mutagenesis that allows not only obtaining mutants with high frequency but also will provide methods for simple screening and identification of desired mutations. Different transposon mutagenesis approaches were applied in streptomycetes research including classic *in vivo* and *in vitro* systems. However, all of them have some disadvantages due to low frequency or locus-specificity of transposition or impossibility of direct phenotypical screening and characterization of obtained mutants. Recently, we reported the development of two synthetic *in vivo* transposon systems based on natural Tn5 and Himar1 transposons and their effective utilization in different streptomycetes species. Both systems show high frequencies of transposition, have low specificity of integration as well as provide a simple and rapid way of identification of mutations. Combining these systems with the sensitive reporter system based on β -glucuronidase gene simplifies selection of regulatory elements controlling particular biosynthetic processes.

The genomic era in streptomycetes research unveiled enormous hidden potential of these bacteria to produce multiple secondary metabolites with new structures and biological activities. Post-genomic research in this field first off all is directed to embody this hidden potential into new antibiotics, immunosuppressants, herbicides etc. First step in this direction is the development of an effective toolbar of genetic manipulations in streptomycetes with the final goal of obtaining a universal host for expression of heterologous secondary metabolites genes. Our current progress in this direction gives hope to develop a full such system including tools for simple and rapid gene identification, deletion, expression and modification. This will open new horizons in studying of cryptic secondary metabolite gene clusters from different sources leading to production of novel biologically active compounds.

Andriy Luzhetskyy born in 1977, obtained his Diploma (1999) and Ph.D. (2004) in Biology at the Ivan Franko Lviv National University, Ukraine. He worked as a PostDoc in the Department of Pharmaceutical Biology and Biotechnology at Freiburg University, Germany (2004-2010). Since 2011 he is the Head of the Junior Research Group "Actinobacteria Metabolic Engineering" at the HIPS in Saarbrücken.

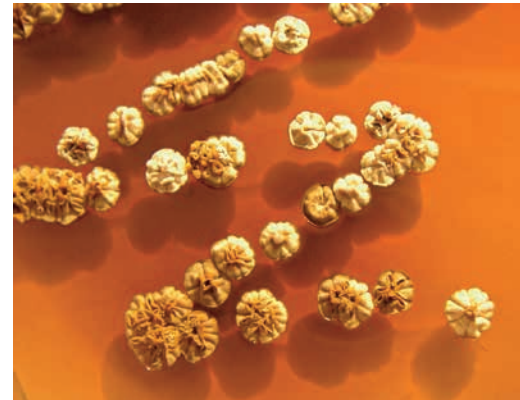

Streptomyces sp. isolated in the Nikitsky Botanical Garden of Crimea (Ukraine)

HIPS/Luzhetskyy



Type-III secretion

Both the flagellum and the injectisome feature a related type-III protein export machine at the base of the respective nanomachines. Injectisome type-III secretion systems secrete effector proteins into eukaryotic host cells which results in the internalization of the bacteria. The bacterial type-III export apparatus is an impressive molecular machine, exhibiting both high speed and stringent substrate discrimination. The secretion apparatus specifically recognizes and exports a few proteins among the many thousands within the cell by using energy from the proton motive force for protein translocation. Although the key proteins have been identified, the mechanism of type-III secretion remains poorly understood. The component(s) that form the trans-membrane conduit for the substrate or harness the proton gradient to energize translocation are still unknown. In addition, no sequence motifs or common patterns have been identified that can be used to accurately predict type-III secreted substrates.

The project

Using a combination of bacterial genetics, microscopy, biochemistry and infection biology techniques we study in our research the mechanisms of bacterial motility during bacteria-host interactions and the molecular function of bacterial type-III secretion systems in the Gram-negative pathogen *Salmonella enterica*. Both bacterial motility and the process of type-III secretion are essential for virulence and, therefore, represent attractive targets for new anti-infectives. Our research will provide novel and fundamental insights into our understanding of the molecular details of *Salmonella* virulence and type-III secretion systems and thereby the initial events required for the commitment of the pathogens to invasive diseases could become clear. Importantly, this knowledge could be used to design specific inhibitors of bacterial type-III secretion systems which might have the potential for new broad-range anti-bacterial agents that are urgently needed at a time when antibiotic resistance is increasing.

Marc Erhardt, born in 1981, obtained his diploma in biology at the University of Konstanz (2006). He did his doctoral thesis (Dr. rer. nat.) at the University of Utah, Salt Lake City USA, and the University of Konstanz (2008-2011). Postdoctoral scientist in the Department of Medicine at the Université de Fribourg, Switzerland (2011-2012). Head of the junior research group Infection Biology of *Salmonella* at the HZI since 2013.



Project Members

Julia Andrea Deditius, Dr. Marc Erhardt, Florian Fabiani, Caroline Kühne

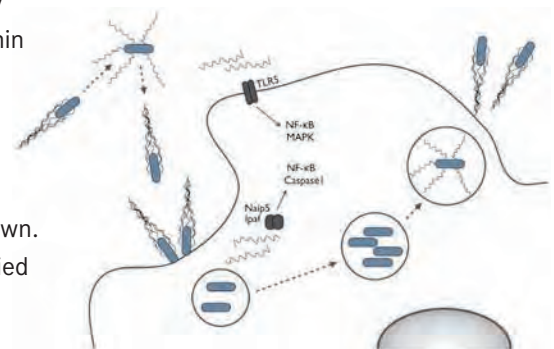

Fig. 2. Schematic overview of the putative invasion and intracellular replication process during Salmonella infection of a eukaryotic host cell. Motility plays a crucial role in movement towards and invasion of a eukaryotic host cell. Extracellular flagellin is recognized by the Toll-like receptor 5 (TLR5). Intracellular flagellin interacts with specific members of the Naip (neuronal apoptosis inhibitor protein) family, which in turn drive assembly and activation of the NLRC4 inflammasome. Intracellular Salmonella replicate inside Salmonella-containing vacuoles (SCV) where flagellar genes presumably are down regulated. Intracellular Salmonella then exit the host cell after the biosynthesis of novel flagella.

© Marc Erhardt

Publications

- Paul, K.,* Erhardt, M.,* Hirano, T., Blair, D.F. & Hughes, K.T. (2008) Energy source of flagellar type III secretion. *Nature* **451**, 489-492.*joint first authors
- Erhardt, M. & Hughes, K.T. (2010) C-ring requirement in flagellar type III secretion is bypassed by FlhDC upregulation. *Molecular Microbiology* **75**, 376-393.
- Erhardt, M., Hirano, T., Su, Y., Paul, K., Wee, D.H., Mizuno, S., Aizawa, S.I. & Hughes, K.T. (2010) The role of the FliK molecular ruler in hook-length control in *Salmonella enterica*. *Molecular Microbiology* **75**, 1272-1284.
- Erhardt, M., Singer, H.M., Wee, D.H., Keener, J.P. & Hughes, K.T. (2011) An infrequent molecular ruler controls flagellar hook length in *Salmonella enterica*. *The EMBO Journal* **30**, 2948-2961.



Project Leader

Dr. Till Strowig

Junior Research Group Microbial Immune Regulation (MIKI)
till.strowig@helmholtz-hzi.de

Interplay of Inflammasomes, Commensals and Pathogens at Mucosal Interfaces

The microbiota and its influence on human health

The microbiota encompasses the diverse population of bacteria, archaea, and fungi that populate many body sites of multicellular hosts. In mammals, the largest number of these organisms can be found in the gastrointestinal tract, with the highest concentrations present in the large intestine. It fulfills essential tasks for the host metabolism in regulating intestinal epithelial integrity and repair, as well as mucosal immune responses. The composition of the microbiota is highly variable depending on body sites but also at the same site within human individuals. The composition of microbiota is considered a complex phenotype shaped by both environmental and host factors including the immune system. In humans specifically, changes in nutrition, immune competence, increased incidence of disease and corresponding use of medication (*e.g.* antibiotics), together with advancing age may result in an altered composition of the microbial community of the gastrointestinal tract and other mucosal territories.

In general the relationship between the host and the microbiota is considered peaceful and even mutualistic, hence members of the microbiota are often named commensal bacteria, from the Latin phrase *cum mensa* “sharing a table”, to distinguish them from pathogenic bacteria. This homeostasis may be disrupted temporarily when pathogens invade, or other environmental

Scanning electron micrograph of intestinal bacteria in close contact with the epithelial barrier. HZI

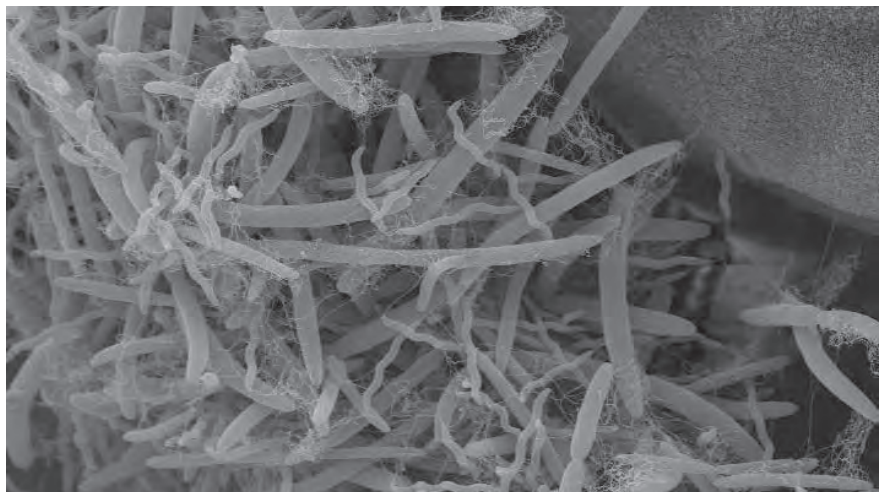

changes such as antibiotic treatment, trigger the development of an imbalanced microbiota called dysbiosis. Strikingly, dysbiosis has also been noted in many human conditions and diseases including obesity, diabetes, and inflammatory bowel disease raising the question of whether dysbiosis is a by-product of the disease or it has a causative function in disease development and progression. The second hypothesis is supported by several studies, which demonstrated that by transplantation of a disease-associated microbiota into germ-free mice, distinct disease characteristics could be transferred. However, the immunomodulatory abilities of specific members of the microbiota are unknown and via which mechanisms these occur.

The project

Recently we discovered a novel role for the NLRP6 inflammasome in regulation of the intestinal microbiota of mice. In its absence, an altered microbiota composition develops that increases the severity of experimentally induced colitis. Strikingly, transfer of the altered microbiota to WT mice resulted in exacerbated colitis in these mice compared to normal WT mice. We are planning to study the detailed mechanisms that are involved in NLRP6 inflammasome mediated regulation of the microbiota and especially which cell types participate in this process. Notably, dysbiosis is observed in many human individuals with immune-mediated diseases, but its impact on other aspects of immunity is less well characterized. Hence, we intend to study the effects of the microbiota, specifically dysbiosis on orchestrating anti-microbial immune responses and the impact in host response to vaccination.

The knowledge emerging from this work is expected to expand our understanding of innate and adaptive immune responses in the intestinal mucosa and pave the road for the development of new therapies and immune interventions against microbial pathogens.

Till Strowig born in 1979, obtained his diploma (Dipl. Ing.) in Medical Biotechnology at the Technical University of Berlin (2004). He did his doctoral thesis (Ph.D.) at The Rockefeller University (2004-2009) and worked for 4 years as postdoctoral scientist at Yale University. Since June 2013 he is heading the Junior Research group "Microbial Immune Regulation" at the HZI.



Project Members

Dr. Till Strowig, Sophie Thiemann

Publications

Henao-Mejia, J., Elinav, E., Jin, C., Hao, L., Mehal, W.Z., Strowig, T., Thaiss, C.A., Kau, A.L., Eisenbarth, S.C., Jurczak, M.J., Camporez, J.P., Shulman, G.I., Gordon, J.I., Hoffman, H.M., Flavell, R.A. (2012) Inflammasome-mediated dysbiosis regulates progression of NAFLD and obesity. *Nature* **482(7384)**, 179-185.

Strowig, T., Rongvaux, A., Rathinam, C., Takizawa, H., Borsotti, C., Philbrick, W., Eynon, E., Manz, M.G., & Flavell, R.A. (2011) Transgenic expression of human SIRPa in Rag2^{-/-} c^{-/-} mice improves engraftment of human hematopoietic cells in humanized mice. *Proceedings of the National Academy of Sciences USA* **108(32)**, 13218-13223.

Strowig, T.*, Elinav, E.*, Kau, A.L., Henao-Mejia, J., Thaiss, C.A., Booth, C.J., Peaper, D.R., Bertin, J., Eisenbarth, S.C., Gordon, J.I., & Flavell, R.A. (2011) NLRP6 Inflammasome Regulates Colonic Microbial Ecology and Risk for Colitis. *Cell* **145(5)**, 745-757. (*equally contributed)

Strowig, T.*, Gurer, C.*, Ploss, A., Rice, C., Young, J.W., Chadburn, A., Cohen, J.I. & Münz, C. (2009) Priming of protective T cell responses in mice with human immune system components following Epstein-Barr virus infection. *Journal of Experimental Medicine* **206(6)**, 1423-1434. (*equally contributed)



Project Leader

Dr. Alexander Titz

Junior Research Group Chemical Biology of
Carbohydrates, HIPS (CBCH)
alexander.titz@helmholtz-hzi.de

Chronic *Pseudomonas aeruginosa* Infections: Towards Anti-Adhesion Therapeutics for Biofilm Dispersal and Inhibition

Carbohydrates and glycoconjugates belong to the three major classes of biopolymers. Complex carbohydrates play important roles in biological recognition processes that are represented by the presence of dense glycoconjugate layers on cells known as the glycocalyx. Despite their importance, the study of carbohydrates suffers from limited methods for their synthesis and analysis contrary to nucleic acids or proteins.

Treatment of chronic infections: disrupting lectin-mediated biofilms

Many human pathogens can establish chronic infections with the help of a biofilm mode of life. As a protective shield, the matrix of the biofilm renders antibiotics ineffective and secures survival of the embedded pathogen. Novel ways for treatment address disintegration of such biofilms and thus restore activity of antibiotics. Frequently, the architecture of biofilms is maintained by carbohydrates and so-called lectins, recognizing and cross-linking carbohydrate motifs

Model of carbohydrate-mediated biofilm formation by Pseudomonas aeruginosa: The tetrameric lectins LecA and LecB maintain the biofilm architecture by cross-linking various glycan structures on the bacterial envelope, the host cell and the exopolysaccharides. Blocking these lectins with small molecules inhibits biofilm formation. HZI

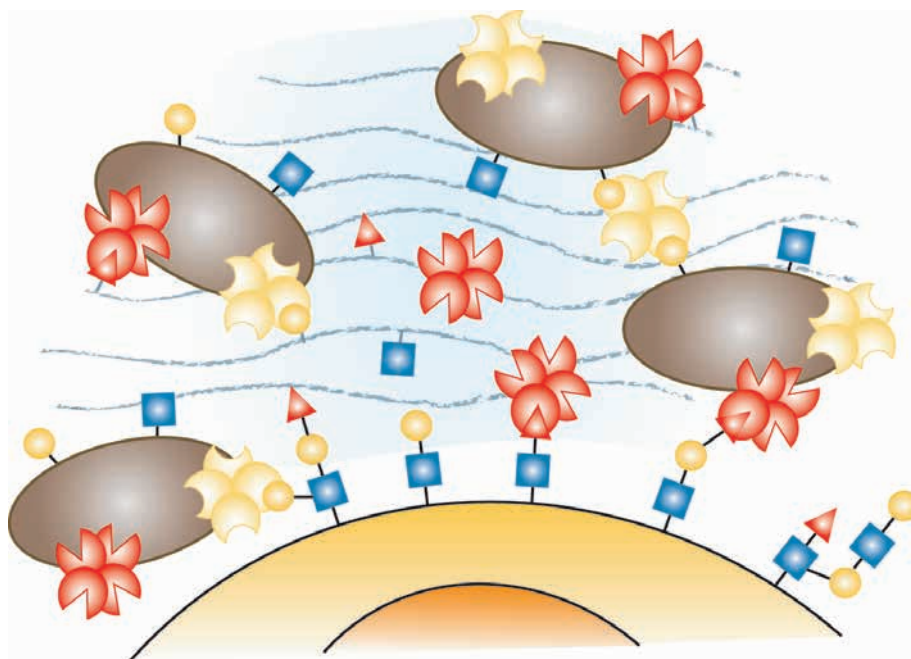

of the glycocalyx, both on human cells and pathogens. The inhibition of such structural components leads to the disruption of a biofilm and thereby allows treatment of the infection. *Pseudomonas aeruginosa* is an important pathogen in hospital-acquired infections and for cystic fibrosis patients. This Gram-negative bacterium can establish chronic infections in various tissues through assembly into protective biofilms. *P. aeruginosa* produces two lectins necessary for biofilm formation, which are focus of our research.

The group of Dr. Alexander Titz aims at the development of antibacterial drugs using a combination of medicinal chemistry, biochemistry and microbiological methods. Recently, a competitive binding assay was developed for the *in vitro* evaluation of inhibitors of the *Pseudomonas* lectins. In collaboration with other groups at HIPS and the HZI, potent molecules obtained by the group are then further evaluated in biofilm and infection models. Such compounds may ultimately lead to successful treatment of chronic infections without evoking resistances among the pathogens.

Alexander Titz born in 1977, obtained his diploma in chemistry at the Technical University of Darmstadt (2004). He did his doctoral thesis in Molecular Pharmacy (Dr. phil.) at the University of Basel (2004-2008). For postdoctoral research, he moved to the Institute of Microbiology and Immunology at ETH Zürich (2008-2010). In 2010, Alexander established an independent research group at the University of Konstanz and moved to HIPS in 2013 to head a Helmholtz Young Investigator Group.



Project Members

Ines Joachim, Roman Sommer,
Dr. Alexander Titz, Dr. Stefanie Wagner

Publications

Hauck, D.,+ Joachim, I.,+ Frommeyer, B.,+ Varrot, A., Philipp, B., Möller, H.E., Imberty, A., Exner, T.E., & Titz, A.* (2013) Discovery of two classes of potent glycomimetic inhibitors of *Pseudomonas aeruginosa* LecB with distinct binding modes. *ACS Chemical Biology* doi:10.1021/cb400371r.

Titz, A. *Patent application*. EP 12 002 531.7 priority date 10. April 2012.

Butschi, A.,+ Titz, A.,+ Walti, M.,+ Oleric, V., Paschinger, K., Guo, X., Nöbauer, K., Seeberger, P., Wilson, I.B.H., Hengartner, M.O., Aebi, M., Künzler, M. (2010) *Caenorhabditis elegans* N-glycan core β -galactoside confers sensitivity towards nematotoxic fungal galectin CGL2. *PLoS Pathogens* **6**(1), e1000717. doi:10.1371/journal.ppat.1000717.

Titz, A.,+ Butschi, A.,+ Henrissat, B., Fan, Y.-Y., Hennen, T., Razzazi-Fazeli, E., Hengartner, M.O., Wilson, I.B.H., Künzler, M., & Aebi, M. (2009) Molecular basis for galactosylation of core fucose residues in invertebrates: Identification of *Caenorhabditis elegans* N-glycan core α -1,6 fucoside β -1,4-galactosyl-transferase GALT-1 as a member of a novel glycosyltransferase family. *Journal of Biological Chemistry* **284**(52), 36223.

Titz, A., Butschi, A., Aebi, M., Wilson, I.B.H., Hengartner, M., Künzler, & M. Core (2010) beta-Galactosyltransferase and uses thereof. *Patent*. WO2010/136209A1.

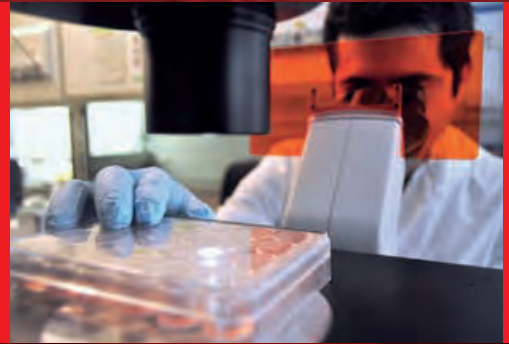



Bacterial and Viral Pathogens

A difficulty in the control of bacterial and viral pathogens is that they exhibit a high degree of diversity. They show strong surface-antigen variations, can rapidly adapt to changing environments and hosts, and have a very complex pathogenesis. Based on these challenges this topic focuses on the in-depth characterization of the biology of bacterial and viral pathogens and host-pathogen interactions to gain a comprehensive understanding of the virulence mechanisms and the complex infection processes. The topic has the three following research aims:

- Infection control – Unraveling risk factors for infections
- Infection strategies – Understanding molecular mechanisms of virulence
- Infection intervention – Novel drug targets and anti-virulence strategies

Photos from left to right:

Ute Widow conducting microscopical experiments (HZI) | Working at a cleanbench (HZI) | Where microscopic details matter – a colleague observing cells microscopically (HZI/Murthy)



Topic speaker

Prof. Dr. Petra Dersch

Department of Molecular Infection

Biology (MIBI)

petra.dersch@helmholtz-hzi.de

Topic: Bacterial and Viral Pathogens

Prevention and treatment of infectious diseases have improved considerably over the last decades due to the widespread use of vaccines and anti-infectives as well as the development of infection control strategies. Nevertheless, infectious diseases still cause substantial morbidity and mortality world-wide. Respiratory tract infections remain a leading cause of severe illness and mortality. Gastrointestinal diseases are still among the most reported diseases in Europe, and represent a huge health problem in all parts of the world with deaths particularly in children younger than 5 years of age. Nosocomial infections and chronic persistent infections are steadily rising because of an increasing number of vulnerable patients due to older age, immunosuppression, and increasingly invasive diagnostic and therapeutic interventions.

Furthermore, in the past years a series of unexpected new infectious diseases emerged, among them many food-borne and zoonotic diseases (e.g. H1N1 influenza A virus epidemic in 2009, and the German EHEC epidemic in 2011), and have illustrated our vulnerability. Our knowledge about the animal and environmental reservoirs of these pathogens is rather low. Crucial virulence mechanisms are still not fully understood and treatment options are often unsatisfactory due to low effectiveness in the reduction of symptoms or antibiotic

Causes of Deaths Worldwide

WHO 2004, estimates for 2002

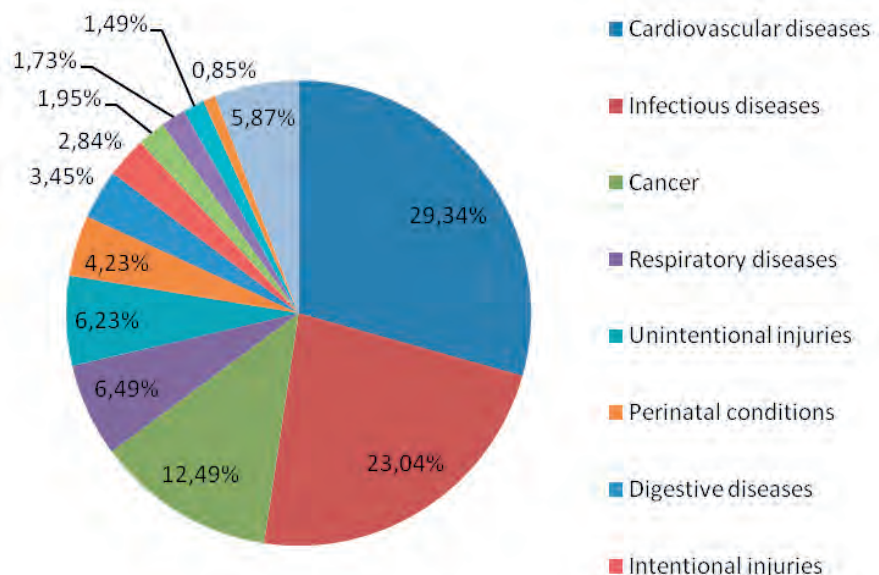

Nosocomial Infections	No. Infected people	No. Deaths
USA	~ 2.000.000	48-99.000
Europe	> 3.000.000	40-100.000

Nosocomial Infections

Estimates from various sources

(WHO 2011, Wikipedia, Right Diagnosis)

resistance. Misuse and overuse of antibiotics in medicine and in the livestock industry has resulted in the selection of multidrug-resistant pathogens, which cannot be eradicated by commonly used antibiotic therapies. The situation is exacerbated through the deficit of effective drugs for many persistent viral diseases and the lack of successful prevention measures. Another difficulty in the control of bacterial and viral pathogens is that they exhibit a high degree of diversity. They show strong surface-antigen variations, can rapidly adapt to changing environments and hosts, and have a very complex pathogenesis. Based on these challenges this topic focuses on the in-depth characterization of the biology of bacterial and viral pathogens and host-pathogen interactions to gain a comprehensive understanding of the virulence mechanisms and the complex infection processes. The topic has the three following research aims:

Infection control – Unraveling risk factors for infections

We have only limited knowledge about (i) the distribution of pathogens in the environment, in animal and in human populations, (ii) the pathogen signatures that are associated with high virulence and infectivity, and (iii) the host risk factors that determine persistence, transmission and infection. To successfully prevent infectious diseases and to reduce the public health burden of disease outbreaks this new research task of the HZI has started to address pathogen-associated factors relevant for transmission, infectiousness, persistence and spread of pathogens. This includes the identification of factors that enable important pathogens to persist and proliferate in external reservoirs, to colonize and infect humans (endogenous reservoirs) and to cause disease. It also implicates pathogen profiling to identify outbreak strains, biomarkers and functional traits of particularly dangerous pathogens (e.g. drug resistance, toxins) required to develop molecular diagnostic tools which are important for rapid detection and early, targeted antimicrobial therapies. Furthermore, conditions that determine the persistence of the pathogens in humans (e.g. certain changes of the composition of the microbiome and special colonization factors) are elucidated. This knowledge can be helpful as predictive markers for the disease outcome and for treatment decisions including dietary, lifestyle and/or pharmacological interventions.

Infection strategies – Understanding molecular mechanisms of virulence

Viral and bacterial pathogens evolve rapidly and display different pathogenicity mechanisms leading to variable clinical manifestations which complicate development of effective antimicrobial drugs. Moreover, environmental and host factors influence host-pathogen interactions through diverse regulatory networks and iterative responses on both sides. Therefore, a comprehensive portrayal of viral and bacterial infection processes, reflecting the dynamic and complex nature of host-pathogen interactions at the system level, is required for this endeavor. One major aim of this research theme is to identify pathogenicity factors and virulence strategies, which can serve as targets for new therapeutic strategies or as antigens for protective vaccines among the complex set of virulence-associated traits. For this purpose virulence mechanisms crucial for i) the initiation of the infection process, including host cell adhesion and invasion, ii) proliferation within the host and iii) establishment of persistent/chronic infections are dissected at the molecular, functional and structural level. A key focus has been the elucidation of bacterial and viral host cell association and invasion mechanisms. Several novel cell adhesion molecules have been identified and interaction with host cell receptors and extracellular matrix proteins were characterized. In addition, microbial subversion of intracellular functions to facilitate host cell entry and transcytosis or to prevent uptake by professional phagocytes are studied. In general, multiple signalling pathways and/or several steps of certain signalling pathways, in particular those controlling rearrangements of the host cell cytoskeleton were found to be targeted by microbial factors from enteric pathogens and streptococci. Qualitative proteome and phosphokinome analyses determining the phosphorylation status of cell signalling molecules were established and used to unravel the spatial and temporal dynamic of microbe-triggered signalling processes. A major line of our research was also devoted to study complex regulatory networks implicating sensory and regulatory RNAs and microbial adaptation processes during different stages of the infection (*e.g.* host-adapted metabolic processes, immune escape mechanisms). These efforts provided a deeper insight into the molecular pathways of infectious diseases and highlighted novel opportunities for development of targeted therapies.

Infection intervention – Novel drug targets and anti-virulence strategies

Traditional antibiotics, which are widely used to combat bacterial infections, induce bacterial lysis or substantial stress, which rapidly selects for resistant subpopulations and can cause undesirable changes of the microbiota leading to a loss of symbiotic benefits. In parallel, directly acting antiviral drugs are challenged by high mutation and replication rates, which pose a substantial challenge for controlling virus replication and resistance. One compelling strategy to classical antimicrobial therapies is to inhibit crucial virulence strategies. This approach aims to find and target the weak points (the Achilles' heel) of a pathogen by inhibiting fundamental pathogenicity mechanisms that initiate the infection, promote persistence and/or cause disease symptoms. This includes compounds that interfere with classical virulence factors such as adhesins/invasins, toxins, master virulence regulators and immune-modulators. Furthermore, establishment of advanced animal models coupled with novel imaging, 'omic' technologies and *in vivo* RNA-seq allowed us to initiate integrative analyses of the complex infection process which will help us to identify novel pathogenicity factors that may serve as potential drug targets. Several teams have started to exploit the knowledge of crucial virulence mechanisms and have developed test assays and high-throughput screening systems towards anti-virulence based drug discovery. Promising candidates of Hepatitis C virus-specific inhibitors and a *Streptococcus* biofilm damaging natural compound have been identified, and many more are expected to be discovered in the near future.

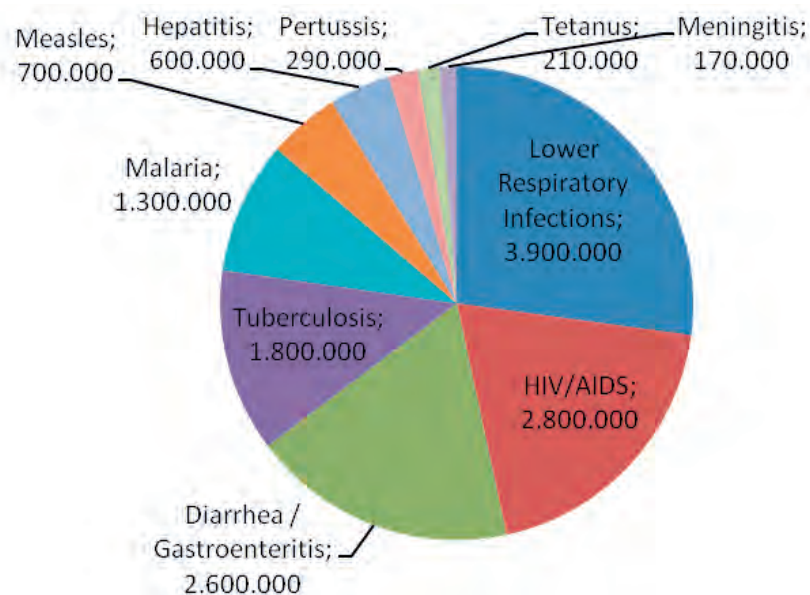

*Infectious Diseases –
No. of Deaths per Year*

Estimations from WHO Data during the Past Decade



Project Leader

Prof. Dr. G. Singh Chhatwal

Department of Medical Microbiology (MMIK)
gsc@helmholtz-hzi.de

Virulence Factors of Streptococci and Pneumococci

Streptococcus pyogenes, *S. dysgalactiae* ssp. *equisimilis* (SDSE) and *S. pneumoniae* cause a wide spectrum of acute infections in humans and a severe autoimmune sequela named rheumatic fever. Morbidity and mortality due to streptococcal infections and their sequelae remain very high. We are elucidating the pathogenicity mechanisms in order to develop novel control strategies.

PARF is a highly relevant trigger of rheumatic fever

Peptide associated with rheumatic fever (PARF) is a collagen binding motif of *S. pyogenes* and SDSE. Moreover it causes the collagen IV autoimmunity in rheumatic fever triggering the autoimmune disease. We have investigated the epidemiological relevance of the PARF motif and showed that about 7% of the *S. pyogenes* and SDSE isolates that cause infections worldwide harbor an active PARF motif.

The correlation of SDSE with rheumatic heart disease is a cause of concern, because carriage of and infections with SDSE are often inadequately treated. We observed that more than 10% of the SDSE isolates from a high incidence region of rheumatic fever had an active PARF motif that leads to autoimmune reaction. This neglected streptococcal species must be taken seriously and should be eradicated.

Fig. 1. *S. agalactiae* heterologously expressing *FbaB* invade endothelial cells via membrane protrusions with massive actin accumulation and reside intracellularly in phagolysosomes. Photo: HZI, Rohde



Vaccines against streptococci

In many regions of the world, antibiotic treatment alone has proven insufficient in prevention of rheumatic fever. Improved diagnosis using our knowledge about PARF and development of a vaccine against the causative streptococci are two important strategies to fight this disease. M protein based vaccines are protective but bear the risk of causing autoimmunity as a side effect. We have identified the streptococcal arginine deiminase and trigger factor as protective antigens and 52 other potential candidate antigens for the development of safe alternative vaccines against pyogenic streptococci.

Streptococcal cell invasion and its consequences

The ability of streptococci to invade host cells protects them from the immune system and from antibiotic treatment. This leads to recurrence of infection and contributes to invasive infections. Streptococci disseminate via the blood circulation and invade endothelial cells through a phagocytosis-like process.

We have shown that FbaB (fibronectin binding protein of group A streptococci, type B) contributes to *S. pyogenes* invasion into endothelial cells (Fig. 1). Uptake into host cells was accompanied by formation of membrane protrusions with massive actin accumulation. Intracellularly, bacteria trafficked along the classical endocytic pathway ending up in phagolysosomes. FbaB is the first identified endothelial cell invasin of *S. pyogenes*.

We observed that adherence of *Streptococcus pneumoniae* to primary human pulmonary microvascular endothelial cells (HPMEC), in combination with sublytic concentrations of pneumolysin, stimulates the exocytosis of Weibel-Palade bodies (Fig. 2) and the secretion of von Willebrand factor and interleukin 8. In conclusion, *S. pneumoniae* induces release of proinflammatory and procoagulative components directly contributing to pathophysiological processes that lead to fatal tissue injury.

Our research provides new insights into the pathogenesis of streptococcal infections and sequelae. Furthermore, it delivers valuable information for translation into better diagnostics, vaccines and treatments.

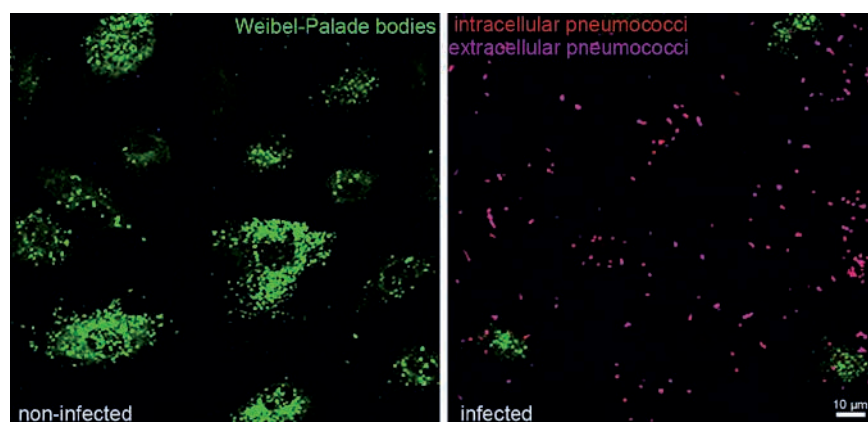

Fig. 2. A) Uninfected endothelial cells (HPMEC) exhibit a high number of Weibel-Palade bodies (green). B) After infection with *S. pneumoniae* Weibel-Palade bodies are released to the outside; note the absence of green staining in the infected (*S. pneumoniae* in pink) HPMEC cells. Photo: HZI, Rohde



Project Members

Dr. Silva Amelung, Dr. René Bergmann, Priv.-Doz. Dr. Simone Bergmann, Prof. Dr. G. Singh Chhatwal, Dr. Marcus Fulde, Giuseppe Gulotta, Angela Hitzmann, Dr. Melanie Lüttge, Dr. Andreas Nerlich, Priv.-Doz. Dr. Patric Nitsche-Schmitz, Prof. Dr. Manfred Rohde, Katharina Rox, Dr. Vivek Sagar, Dr. Susanne Talay

Publications

Sharma, A., Kumar Arya, D., Dua, M., Chhatwal, G. S., & Johri, A. K. (2012) Nano-technology for targeted drug delivery to combat antibiotic resistance. *Expert Opinion on Drug Delivery* **9**, 1325-1332.

Henningham, A., Chiarot, E., Gillen, C. M., Cole, J. N., Rohde, M., Fulde, M., Ramachandran, V., Cork, A. J., Hartas, J., Magor, G., Djordjevic, S. P., Cordwell, S. J., Kobe, B., Sriprakash, K. S., Nizet, V., Chhatwal, G. S., Margarit, I. Y., Batzloff, M. R., & Walker, M. J. (2012) Conserved anchorless surface proteins as group A streptococcal vaccine candidates. *Journal of Molecular Medicine (Berl)* **90**, 1197-1207.

Reissmann, S., Gillen, C. M., Fulde, M., Bergmann, R., Nerlich, A., Rajkumari, R., Brahmadathan, K. N., Chhatwal, G. S., & Nitsche-Schmitz, D. P. (2012) Region specific and worldwide distribution of collagen-binding M proteins with PARF motifs among human pathogenic streptococcal isolates. *PLoS One* **7**, e30122.

Lüttge, M., Fulde, M., Talay, S. R., Nerlich, A., Rohde, M., Preissner, K. T., Hammerschmidt, S., Steinert, M., Mitchell, T. J., Chhatwal, G. S., & Bergmann, S. (2012) *Streptococcus pneumoniae* induces exocytosis of Weibel-Palade bodies in pulmonary endothelial cells. *Cellular Microbiology* **14**, 210-225.

Amelung, S., Nerlich, A., Rohde, M., Spellerberg, B., Cole, J. N., Nizet, V., Chhatwal, G. S., & Talay, S. R. (2011) The FbaB-type fibronectin-binding protein of *Streptococcus pyogenes* promotes specific invasion into endothelial cells. *Cellular Microbiology* **13**, 1200-1211.



Project Leader

Prof. Dr. Petra Dersch

Department of Molecular Infection

Biology (MIBI)

petra.dersch@helmholtz-hzi.de

Function and Regulation of *Yersinia* Virulence Factors

Enteropathogenic *Yersinia* species, *Y. pseudotuberculosis* and *Y. enterocolitica*, are faecal-oral zoonotic pathogens, which are ranked as pathogens of high importance in Germany. They colonise the intestinal tract and cause a large variety of gut-associated diseases in humans, ranging from diarrhoea, enterocolitis, and terminal ileitis to mesenteric lymphadenitis, that are collectively called yersiniosis. The diseases are typically self-limiting, although, sequelae such as reactive arthritis, erythema nodosum and thyroiditis are also common.

Yersiniae are widely distributed and contaminated pork is the main source of infection for men. They express a set of special surface structures which allow them to bind and internalize into host cells. These outer membrane proteins (adhesins and invasins) promote efficient attachment to cell receptors, which results in the induction of certain signal transduction pathways within the cell. Recruitment and activation of certain signal molecules to bacteria bound cell receptors induce rearrangements of the actin cytoskeleton and lead to the formation of special membrane protrusions which migrate around the bacteria and enclose it into a membrane-bound phagosome. Cell invasion allows transcytosis of the bacteria through the gut epithelium, into the underlying lymphatic tissues and deeper organs. We focus on the characterization of the function and expression of *Yersinia* invasion factors to gain more information about how enteric bacteria colonise host tissues and become resistant against the host immune system.

Molecular analysis of the *Yersinia*-induced signal transduction in epithelial cells

In order to identify signalling pathways which are essential for the internalization of *Yersinia pseudotuberculosis*, we studied the cell uptake promoted by the *Yersinia* invasion factors InvA and YadA which interact directly or indirectly via extracellular matrix proteins with β_1 -integrin receptors of the host cell. By co-localization studies and kinase activation assays, we could demonstrate that the protein kinase B (Akt), the phospholipase C- γ and variants of the protein kinase C are recruited to bacteria-bound membranes and are activated in a time-dependent manner. Application of inhibitors and use of knock-out cell lines and RNA interference demonstrated that activation of these factors occurs after activation of the integrin-bound focal adhesion kinase (FAK), c-Src and the

PI3 kinase, and are required for the bacterial entry process. Furthermore, we obtained evidence that, besides the small GTPase Rac-1, also other GTPases of the Rho family and different actin-associated proteins, such as N-WASP and the Arp2/3 complex, are implicated in the uptake process. Furthermore, we characterized two newly identified adhesins of *Y. pseudotuberculosis* with high homology to the invasin protein, and found that both promote tight binding to human enterocytes. First analyses in the mouse infection model revealed that loss of the adhesins prolonged the life time of infected mice significantly.

Temperature-dependent expression of *Yersinia* virulence factors

Another important goal is to understand the molecular control mechanism of *Yersinia* virulence genes during the infection process. Temperature is one of the most crucial factors sensed by the pathogens to adjust expression of their virulence factors after entry from a cold external environment into a warm-blooded host. We found that the regulator protein RovA controlling expression of the invasin protein undergoes a reversible conformational change upon a temperature shift from 30°C to 37°C. This reduces the DNA-binding affinity of the regulator and renders it more susceptible for proteolysis by the bacterial protease Lon. In addition, other post-transcriptional regulatory mechanisms were analyzed. These control systems are used to adjust virulence gene expression during the infection process to availability of nutrients and stress superimposed by the host immune system.

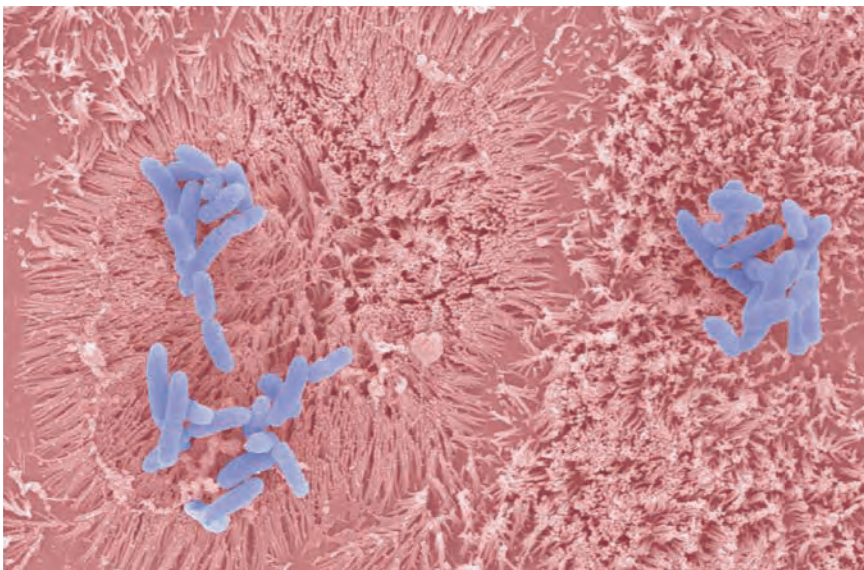

Project Members

Prof. Dr. Petra Dersch, Dr. Ann Kathrin Heroven, Dr. Annika Kochut, Chriselle Mendonca, Dr. Aaron Nuss, Wiebke Opitz, Dr. Fabio Pisano, Julia Schaaake, Stephanie Seekircher, Rebekka Steinmann, Tanja Thiermann, Barbara Waldmann

Adherent Y. enterocolitica on human epithelial cells. Photo: HZI, Rohde

Publications

Herbst, K., Bujara, M., Heroven, A.K., Opitz, W., Weichert, M., Zimmermann, A. & Dersch, P. (2009) Intrinsic thermal sensing controls proteolysis of *Yersinia* virulence regulator RovA. *PLoS Pathogens* **5**(5), e1000435.

Uliczka, F., Kornprobst, T., Eitel, J., Schneider, D. & Dersch, P. (2009) Cell invasion of *Yersinia pseudotuberculosis* by invasin and YadA requires protein kinase C, PLC- γ 1 and Akt kinase. *Cellular Microbiology* **11**, 1782–1801.

Heroven, A.K., Böhme, K., Rohde, M. & Dersch, P. (2008) A Csr regulatory system, including small non-coding RNAs, regulates the global virulence regulator RovA of *Yersinia pseudotuberculosis* through RovM. *Molecular Microbiology* **68**, 1179–1195.



Project Leader

Prof. Dr. Thomas Pietschmann

Institute of Experimental Virology,
TWINCORE (EVIR)
thomas.pietschmann@twincore.de

A Cellular Lipase Helps Flaviviruses to Release Infectious Viral Progeny

Viruses are intracellular parasites. They usurp cellular factors and machineries in order to propagate their viral genome and to release novel progeny virions for infection of new host cells. In the course of this project, we searched for cellular factors that facilitate release of infectious hepatitis C virus (HCV) particles.

HCV, like also influenza A viruses or Coronaviruses, belongs to the group of enveloped viruses. These viruses have in common that they wrap their viral genome contained in a protein shell with a lipid and protein rich membrane layer. This lipid membrane is acquired in a complex process at the surface of infected cells or within the cell at intracellular host membranes. Subsequently, the enveloped mature virus particles are liberated to meet and infect new target cells. If the virus envelope does not have the proper composition, these viruses are unable to infect new cells and the chain of infection events is interrupted.

Results

To identify novel host factors required for the assembly of HCV progeny, we used an alternative approach. Rather than manipulating individual host factors, we interfered with central signalling cascades of HCV host cells. Such

Assembly of infectious HCV particles within a human hepatocyte. The HCV core protein (red color) which encases the viral genome and builds capsids is located on the surface of cellular lipid droplets (green color). From there it is recruited to intracellular membranes to initiate membrane envelopment. These steps likely occur at subdomains of the endoplasmic reticulum in close proximity to lipid droplets. DNA in cellular nuclei was stained in blue.

Photo: TWINCORE, Gentzsch

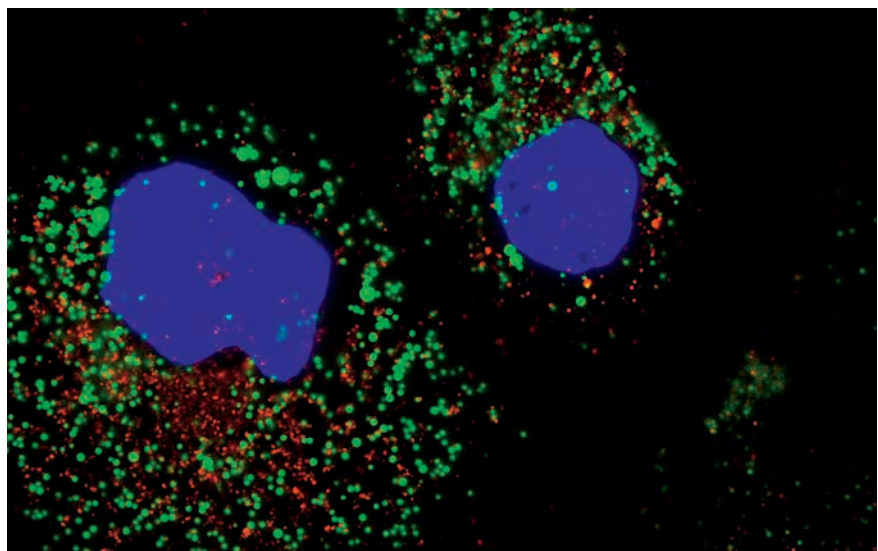

cascades regulate abundance and activity of a large number of cellular factors. Consequently, this strategy permits the blockade of specific host functions thus revealing a possible dependence of the virus on these specific cellular pathways.

Using this approach, we observed that a blockade of the mitogen-activated protein kinase pathway (MAPK-pathway) inhibited HCV propagation. Further molecular analyses revealed that the cellular cytosolic phospholipase A2 (PLA2G4A), an enzyme which is activated by the MAPK-pathway, is crucial for assembly of infectious HCV particles. At the same time, this enzyme plays an important role to initiate inflammatory reactions within cells. Specifically, PLA2G4A is recruited to the ER where it cleaves defined membrane lipids. This cleavage liberates a specific fatty acid, the so called arachidonic acid, which serves as building block for the synthesis of a number of inflammatory mediators. Moreover, the local cleavage of membrane lipids by PLA2G4A modifies the curvature and fluidity of these membranes.

Using inhibitors of PLA2G4A we were able to show that blocking this enzyme results in the production of aberrant HCV particles with disturbed membrane composition. As a consequence, these particles are poorly infectious. Interestingly, exogenous addition of arachidonic acid, the cleavage product of the enzymatic activity of PLA2G4A, restored production of infectious HCV particles suggesting that membrane associated arachidonic acid plays an essential role for the production of fully infectious HCV particles.

Remarkably, we observed that blocking of PLA2G4A not only inhibits HCV but also the related Dengue Virus that also assembles infectious particles at intracellular membranes. In contrast, the vesicular stomatitis virus, an animal pathogen that produces viral progeny at the cell surface, was not inhibited. These findings suggest that besides HCV and Dengue Viruses, other viruses that also assemble at intracellular membranes may depend on this cellular enzyme.

Therefore, we are now exploring if use of PLA2G4A is common to other human pathogenic viruses that use intracellular membranes to assembly infectious progeny (e.g. Coronaviruses). In parallel, we are testing other small molecules known to inhibit PLA2G4A. Some of these compounds are developed by pharmaceutical companies as inhibitors of inflammatory diseases. In the long run we aim to find out if manipulation of PLA2G4A function is a possible antiviral strategy for hepatitis C and other viral diseases (e.g. Dengue fever). A patent application that secures PLA2G4A as target for development of antiviral therapies against flaviviruses was recently filed.



Project Members

Dr. Dorothea Bankwitz, Anne Frentzen,
Dr. Juliane Gentzsch, Dr. Sibylle Haid,
Kathrin Hüging, Dr. Nicolas Menzel,
Prof. Dr. Thomas Pietschmann

Publications

Menzel, N., Fischl, W., Hueging, K., et al. (2012) MAP-kinase regulated cytosolic phospholipase A2 activity is essential for production of infectious hepatitis C virus particles. *PLoS Pathogens* **8**, e1002829.

Haid, S., Novodomska, A., Gentzsch, J., et al. (2012) A plant-derived flavonoid inhibits entry of all HCV genotypes into human hepatocytes. *Gastroenterology* **143**, 213-222 e5.

Ciesek, S., von Hahn, T., Colpitts, C.C., et al. (2011) The green tea polyphenol, epigallocatechin-3-gallate, inhibits hepatitis C virus entry. *Hepatology* **54**, 1947-1955.

Pietschmann, T., Kaul, A., Koutsoudakis, G., et al. (2006) Construction and characterization of infectious intragenotypic and intergenotypic hepatitis C virus chimeras. *Proceedings of the National Academy of Sciences USA* **103**, 7408-7413.

Wakita, T., Pietschmann, T., Kato, T., et al. (2005) Production of infectious hepatitis C virus in tissue culture from a cloned viral genome. *Nature Medicine* **11**, 791-796.



Project Leader

Priv.-Doz. Dr. Eva MedinaResearch Group Infection Immunology (INI)
eva.medina@helmholtz-hzi.de

Mechanisms of Host Defense Against Infection with *Staphylococcus aureus*

Staphylococcus aureus is one of the leading causes of both community-associated and nosocomial infections worldwide. It has developed resistance to a wide range of antibiotics, which complicates the treatment of infections. In particular, methicillin-resistant *S. aureus* (MRSA) has become a worldwide problem. Therefore, new therapeutic options with novel modes of action that bypass the development of resistance are required to tackle the problem posed by *S. aureus* infections in a more effective way. In this regard, therapeutic approaches aimed to enhance the efficiency of the host immune response to eliminate *S. aureus* may represent the best choice. However, in order to understand how the immune system can be manipulated to achieve a more efficient control of infection, we first need to obtain a clear understanding of how the host's immune system responds to *S. aureus*. To achieve this understanding is one of the key objectives of the Infection Immunology Research Group.

Fig. 1. Depletion of DCs aggravates the severity of *S. aureus* bloodstream infection. CD11c-DTR transgenic mice were treated with DT to deplete DCs (with DT) or with PBS vehicle (w/o DT) as control and infected intravenously with *S. aureus*. A: Survival curves of DCs-depleted (black symbols) and non-depleted (white symbols) mice after intravenous inoculation with *S. aureus*. B: Bacterial loads in the lungs, kidneys and livers of DCs-depleted (black bars) and non-depleted (white bars) mice at 24 h after bacterial inoculation. Figure: HZI

Dendritic cells are central coordinators of the host immune response to *S. aureus* infection

Dendritic cells play an important role in the integration of the immune responses induced by pathogens. Using a mouse model of staphylococcal bacteremia, we have investigated the importance of dendritic cells in host defense against *S. aureus*. We found that depletion of dendritic cells resulted in substantial worsening of pathogen clearance and in accelerated mortality of *S. aureus*-infected mice (see Fig. 1). An additional finding of this study was that the beneficial role afforded by the dendritic cells during *S. aureus* infection might be mediated, at least in part, by the production of IL-12 since the detrimental effect of dendritic

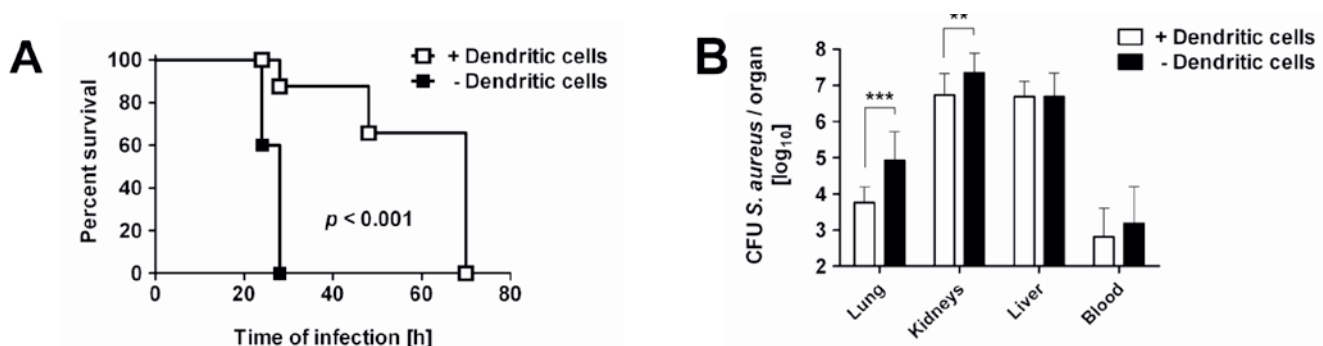

cells depletion was practically reversed by treatment with exogenous recombinant IL-12. In conclusion, we provide compelling evidence that dendritic cells are key coordinators of the immune response to *S. aureus* infection. This data may be of use in future studies for the development of new strategies for the treatment of *S. aureus* infections.

T cells are critical for the control of *S. aureus* infection

Long-lasting protective immunity against pathogens depends on B and T cell mechanisms. As little is known about the adaptive immune responses to *S. aureus*, we here investigated the importance of B and T cells for the control of *S. aureus* during *in vivo* infection. Using different experimental approaches including a whole genome microarray combined with histology and flow cytometry, we have provided unequivocal evidence that the adaptive immune system is critical for the containment of *S. aureus* infection (see Figure 2). This postulation was confirmed by the demonstration that B and T cell-deficient RAG2^{-/-} mice were less capable of restraining bacterial growth than immunocompetent mice. Most importantly, reconstitution with T but not with B lymphocytes significantly improved the capacity of RAG2^{-/-} mice to control *S. aureus* indicating that T cells rather than B cells were involved in this process. Our results demonstrated that T cells and specifically CD4⁺ T cells are critical for controlling *S. aureus* infection. Therefore, CD4⁺T cell epitopes would be ideal targets for the inclusion in a *S. aureus* vaccine.

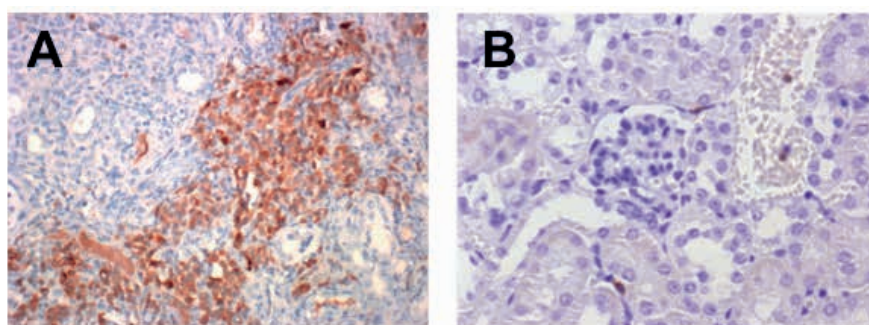

Fig. 2. T cells are recruited into the site of infection in *S. aureus*-infected mice. (A) Immunostaining of a *S. aureus* infected kidney section showing the infiltration of CD3⁺ T cells (brown-stained cells). A kidney section from an uninfected animal stained for CD3⁺ T cells is shown in B. Original magnification, $\times 20$ (A) and $\times 40$ (B). Figure: HZI



Project Members

Dr. Oliver Goldmann, Dr. Sarah Horst, Priv.-Doz. Dr. Eva Medina, Dr. Andrew Oxley, Anna Szafranska

Publications

Horst, S.A., Hoerr, V., Beineke, A., Kreis, C., Tuschscherr, L., Kalinka, J., Lehne, S., Schleicher, I., Köhler, G., Fuchs, T., Raschke, M.J., Rohde, M., Peters, G., Faber, C., Löffler B., & Medina E. (2012) A Novel Mouse Model of *Staphylococcus aureus* Chronic Osteomyelitis That Closely Mimics the Human Infection: An Integrated View of Disease Pathogenesis. *American Journal of Pathology* **181**,1206-1214.

Schindler, D., Gutierrez, M.G., Beineke, A., Rauter, Y., Rohde, M., Foster, S., Goldmann, O., & Medina E. (2012) Dendritic Cells Are Central Coordinators of the Host Immune Response to *Staphylococcus aureus* Bloodstream Infection. *American Journal of Pathology* **181**, 1327-1337.

Ziegler, C., Goldmann, O., Hobeika, E., Geffers, R., Peters, G., & Medina E. (2011) The dynamics of T cells during persistent *Staphylococcus aureus* infection: from antigen reactivity to *in vivo* anergy. *EMBO Molecular Medicine* **3**, 652-666.

Tuschscherr, L., Medina, E., Hussain, M., Völker, W., Heitmann, V., Niemann, S., Holzinger, D., Roth, J., Proctor, R.A., Becker, K., Peters, G., & Löffler B. (2011) *Staphylococcus aureus* phenotype switching: an effective bacterial strategy to escape host immune response and establish a chronic infection. *EMBO Molecular Medicine* **3**, 129-141.

Goldmann, O., Hertzén, E., Hecht, A., Schmidt, H., Lehne, S., Norrby-Teglund, A., & Medina E. (2010) Inducible cyclooxygenase released prostaglandin E2 modulates the severity of infection caused by *Streptococcus pyogenes*. *Journal of Immunology* **185**, 2372-2381.



Project Leader

Prof. Dr. Dietmar Pieper

Research Group Microbial Interactions
and Processes (MINP)
dpi@helmholtz-hzi.de

Metabolic Diversity

Bacteria living in complex communities at scales that outnumber human cells colonize the human body. While these host-associated microbes are beneficial for human health, niches on the human body are also reservoirs for opportunistic pathogens. As an example, the human anterior nares are the major reservoir and thus risk factor for invasive infections by *Staphylococcus aureus*, an increasingly multi-resistant pathogen causing a large spectrum of infectious diseases.

To this end, we surveyed for the prevalence and molecular epidemiology of methicillin-resistant *Staphylococcus aureus* in nursing home residents in Braunschweig (Germany), as nursing home residents are a population at risk for carrying methicillin-resistant *Staphylococcus aureus* (MRSA).

Among the 32 participating nursing homes of the available 34 in the region, 68% of residents (1827 of 2688) were screened for nasal and/or wound colonization. A total of 139 residents (7.6%; 95% confidence interval: 6.4–8.8%) were identified as MRSA positive, almost six-fold more than the 24 MRSA carriers (0.9%) expected according to the nursing homes' pre-test information. Although known risk factors including urinary tract catheters, wounds, preceding hospital admission, and high-grade resident care were confirmed, none was sensitive enough to be considered as the sole determinant of MRSA carriage. Spa typing revealed that more than 70% of isolates belonged to the Barnim strain (ST-22, EMRSA-15, CC22) typical for hospital-acquired MRSA in Northern Germany. There was no evidence for the presence of community-acquired or livestock-associated *S. aureus* strains. This data shows that in Northern Germany MRSA has spread from the hospital environment to other healthcare institutions, which must now be regarded as important reservoirs for MRSA transmission.

Also, our knowledge on the composition of the nasal microbiota as a whole has increased substantially over the last couple of years, particularly as we have employed the newest of high-throughput methods allowing us to sample even more volunteers than before. Firstly, we sought to analyze a greater cross-section of the population by sampling 100 volunteers in Northern Germany. After optimizing and validating the method of terminal restriction fragment length polymorphism (TRFLP) against six previously pyrosequenced samples,

abundant species could be discriminated and their relative abundances measured in a high-throughput manner. The 100 volunteers could be statistically clustered into 12 groups, where two-thirds of volunteers shared more than 40% similarity in respect to their bacterial community structure, while the remaining third clustered into smaller groups being dominated by *Dolosigranulum pigrum*, *Moraxella spp.* or *Staphylococcus aureus*. *Moraxella spp.* was present predominantly in women rather than in men. Then, we assessed the temporal dynamics and variation of the global nasal bacterial community across 25 healthy volunteers (from the Braunschweig area) over 15 months. Overall, there was a global seasonal shift in bacterial community structure. Such a temporal shift was also strongly evident in the abundances of species such as *Propionibacterium acnes* and *Staphylococcus epidermidis*. However, such species dynamics over time was also inter-individual-dependent, and both individuals with highly stable communities and those with highly flexible communities could be defined. Even though the bacterial community of individual volunteers was generally variable over time and permanent carriage of a given species was seldom observed, various species - previously defined as constituting the core bacterial community - could be identified as persistent in a subset of the volunteers suggesting that these same species also constitute to a 'temporal' core community.



Project Members

Amelia Camarinha-Silva, Diego Chaves, Marcia Duarte, Dr. Ruy Jauregui, Daiana Morales, Prof. Dr. Dietmar Pieper, Dr. Ramiro Vilchez-Vargas, Dr. Melissa Wos-Oxley

Publications

Pfingsten-Würzburg, S., Pieper, D.H., Bautsch, W., & Probst-Kepper, M. (2011) Prevalence and molecular epidemiology of methicillin-resistant *Staphylococcus aureus* in nursing home residents in northern Germany. *Journal of Hospital Infection* **78**, 108-112.

Camarinha-Silva, A., Wos-Oxley, M.L., Jauregui, R., Becker, K., & Pieper, D.H. (2012) Validating T-RFLP as a sensitive and high-throughput approach to assess bacterial diversity patterns in human anterior nares. *FEMS Microbiology Ecology* **79**, 98-108.

Camarinha-Silva, A., Jauregui, R., Pieper, D.H., & Wos-Oxley, M.L. (2012) The temporal dynamics of bacterial communities across human anterior nares. *Environmental Microbiology Reports* **4**, 126-132.

Wos-Oxley, M., Bleich, A., Oxley, A.P., Kahl, S., Janus, L., Smoczek, A., Nahrstedt, H., Pils, M., Taudien, S., Platzer, M., Hedrich, H.J., Medina, E., & Pieper, D.H. (2012) Comparative evaluation of establishing a human gut microbial community within rodent models. *Gut Microbes* **3**(3), 234-249.

Vilchez-Vargas, R., Geffers, R., Suárez-Diez, M., Con-
te, I., Waliczek, A., Kaser, V.S., Kralova, M., Junca, H.,
& Pieper, D.H. (2013) Analysis of the microbial gene
landscape and transcriptome for aromatic pollutants
and alkane degradation using a novel internally
calibrated microarray system. *Environmental Micro-
biology*, doi: 10.1111/j.1462-2920.2012.02752.x.



Project Leader

Dr. Wolf-Rainer Abraham

Research Group Chemical Microbiology (CMIK)
wolf-rainer.abraham@helmholtz-hzi.de

Biofilm Communities

The Project recognises symbiotic communities of micro-organisms in biofilms as functional units and pursues the goal of finding new pathways to control them by means of investigation of the diversity of microbial species and their interaction. The primary focus here is the fact that bacteria, in a natural setting, do not in most cases live as pure strains; rather, they live in communities. It is particularly interesting how pathogenic bacteria behave in the host and how they interact with non-facultative or facultative pathogenic bacteria in biofilms within the human body.

Development of dental biofilms

A considerable complication in the clinic is the infection of implants that are usually associated with the formation of biofilm on the implant. Such biofilms are difficult to combat since bacteria in biofilms feature special protective mechanisms against antibiotics and the immune system. Problems emerge particularly within the oral cavity, which by nature exhibits a plethora of various bacteria. To find out which bacteria occupy implants in the oral cavity, we examined two-week-old biofilms from various patients' dental-implants. We found complex communities of bacteria in each case. When one compares these bacterial communities with those of infected implants, it becomes clear that infected implants exhibit a much larger quantity of different bacteria than

Measured and modelled implementation of a ^{13}C -marked toxic metabolite into a fatty acid of two bacterial species of a consortium. One can clearly see that the single bacterium decomposes the metabolite quicker, but only uses it to a low degree (triangle). The other bacterial species is slower but embeds the carbon of the metabolite better into the fatty acids (circles). This behaviour guarantees the survival of the community under shifting environmental conditions.

Figure: HZI

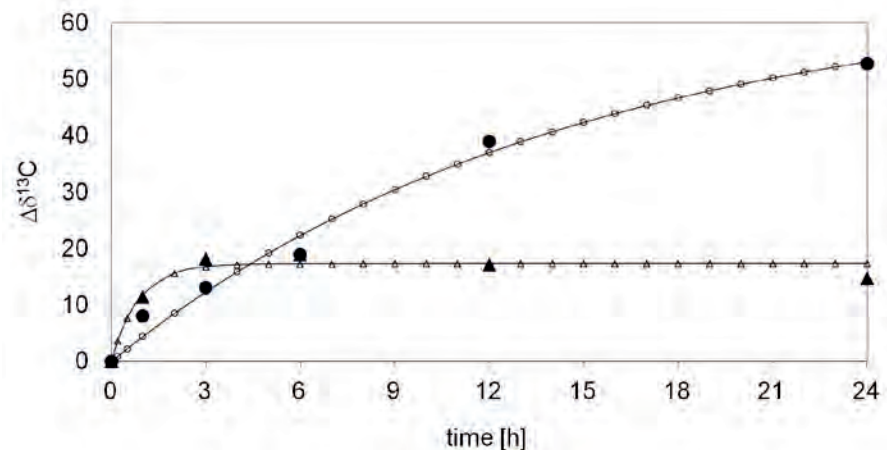

healthy implants. We were able to show through statistic analysis that the bacterial communities in infected implants are quite characteristic for the particular patient; this is however rarely the case with healthy implants. Furthermore, it is interesting to note that the biofilm communities are apparently dependent upon the position of the implant within the mouth, for example incisors exhibit different bacteria compared to molars.

Metabolic activities in biofilms

The awareness of which bacteria appear where in which biofilms, is however only the first step towards understanding the complex phenomenon of biofilm. Substrate-uses on the part of individual bacteria within the biofilm community are also an important factor. In order to clarify how quickly and how comprehensively a substrate is inundated with bacteria, we implement substrates that are marked with stable isotopes and track their formation into the individual species of bacteria. Thus we can determine kinetics and modulate the flow of substances within the community (see figure). In order to facilitate clarification of not only interactions of bacteria together, but also interdependencies of host-bacteria, we began conducting such studies in cell-cultures and/or animal models. Since this involved non-radioactive materials, no special safety measures were required. We discovered another interaction between bacteria and host when we exposed the body's own anti-microbial peptide defensin to *E. coli*. The bacteria subsequently produced adenosine, about which is known that it modulates the immune response. This could be significant for the treatment of infectious intestinal diseases.

Natural substances for the control of biofilms

It is the goal of these examinations to modulate biofilm communities and to expel the pathogenic bacteria from them. We utilize natural substances for this purpose but are also looking for new substances in fungi. Our initial investigation of fungi-isolates revealed that a series of quite differentiated natural substances is quite capable of dissolving biofilms of pathogenic bacteria, without functioning as an antibiotic. We found links from the class of the roridines, which are evidently able to inhibit, quite-specifically, certain fungi. Unfortunately, many of these compounds are also cytotoxic, so that the effective spectrum had to be carefully chosen. A small molecule that we named comatus-lacton is capable of dissolving biofilms of pathogenic bacteria, without acting as an antibiotic and without exhibiting such toxicity.



Project Members

Dr. Wolf-Rainer Abraham, Andreia B. Estrela, Rolf Kramer, Dr. Heinrich Lünsdorf, Maira Peres de Carvalho, Esther Surges

Publications

Heuer, W., Stiesch, M., & Abraham, W.-R. (2011) Microbial diversity of supra- and subgingival biofilms on freshly colonized titanium implant abutments in the human mouth. *European Journal of Clinical Microbiology & Infectious Diseases* **30**, 193-200.

Pawelczyk, S., Bumann, D., & Abraham, W.-R. (2011) Kinetics of carbon sharing in a bacterial consortium revealed by combining stable isotope probing with fluorescence-activated cell sorting. *Journal of Applied Microbiology* **110**, 1065-1073.

Estrela, A.B., & Abraham, W.-R. (2011) Adenosine in the inflamed gut: a Janus faced compound. *Current Medicinal Chemistry* **18**, 21791-2815.



Project Leader

Prof. Dr. Susanne Häußler

Department of Molecular Bacteriology (MOBA)
susanne.haeussler@helmholtz-hzi.de

Pathogenesis of Chronic *Pseudomonas aeruginosa* Infections

The diagnostic and therapeutic strategies that have served us well in the treatment of acute bacterial diseases have not yielded favorable outcomes when applied to chronic infections where bacteria grow in matrix-enclosed sessile biofilm communities. Although every single cell is able to induce a stress response with a characteristic change in the expression pattern, living within populations provides a species with additional mechanisms of survival, the most obvious one being heterogeneity and cooperation.

Diversity facilitates survival

Pseudomonas aeruginosa is the most dominant bacterial pathogen causing chronic lung infection in cystic fibrosis (CF) patients. Although most patients are colonized only with one or few *P. aeruginosa* clones, the isolation of various morphotypes is a very characteristic microbiological finding. This diversity seems to play a key role in the persistence of chronic lung infections. Our research focusses on the elucidation of the molecular mechanisms responsible for this diversity and the characterization of particularly well adapted *P. aeruginosa* biofilm phenotypes.

Phenotypic variability of biofilm-grown P. aeruginosa isolates.

Easy3D-projections represent 48h old biofilms of 15 clinical P. aeruginosa isolates and the lab strain PA14 stained with the BacLight bacterial viability kit. Viable bacteria are stained in green (Syto 9), dead bacteria in red (propidium iodide).

Figure: HZI

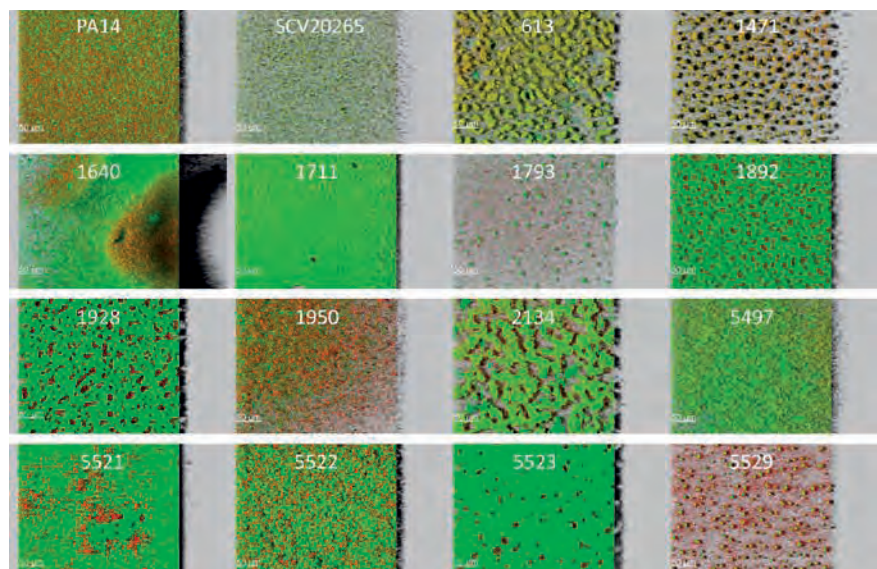

Small colony variants

We have previously demonstrated that an adherent sub-group of so called small colony variants (SCVs) is selected in the CF lung. By applying whole genome sequencing approaches we have identified mutations that could be associated with increased intracellular c-di-GMP levels and thus were demonstrated to be responsible for the switch to an auto-aggregative SCV phenotype. The identification of genotypes that are specifically selected at different stages of chronic infections will significantly advance our knowledge on the evolution and adaptation mechanisms of *P. aeruginosa* to its habitat. In this context not only SCVs but also other bacterial phenotypes that evolve during persistent *P. aeruginosa* infections in the CF lung, such as antimicrobial resistant isolates and biofilm phenotypes, are of particular interest. Extensive phenotype-genotype correlation studies are performed to elucidate the genetic determinants of infection relevant phenotypes.

Cooperation is supported by communication

Apart from two homoserine lactones, *P. aeruginosa* produces a third intercellular signal that is referred to as the Pseudomonas quinolone signal (PQS). PQS is involved in cell density-dependent virulence factor regulation – also known as quorum sensing (QS) – and the establishment of biofilms. However, the molecular mechanisms underlying downstream PQS signalling are largely unknown. PqsE, encoded on the last gene of the PQS biosynthetic operon, seems to play a key role in the translation of the presence of the PQS signal into bacterial behavior at the single cell level. The elucidation of the function of this important enzyme is a major focus of the group.

In summary, the identification of molecular mechanisms and bacterial biomarkers that can predict disease outcome of *P. aeruginosa* infections is a major focus of the group. Knowledge of their identity might eventually lead to the establishment of molecular diagnostic test systems for a reporting of *P. aeruginosa* resistance and pathogenicity profiles and thus may impact on therapeutic strategies and mitigate the future potential to evolve resistance.



Project Members

Stephan Brouwer, Dr. Andreas Dötsch, Dr. Denitsa Eckweiler, Prof. Dr. Susanne Häußler, Dr. Klaus Hornischer, Dr. Juliane Schmidt, Sebastian Schulz

Publications

Pustelny, C., Brouwer, S., Müsken, M., Bielecka, A., Dötsch, A., Nimtz, M., & Häußler, S. (2013) The peptide chain release factor methyltransferase PrmC is essential for pathogenicity and environmental adaptation of *Pseudomonas aeruginosa* PA14. *Environmental Microbiology* **15**(2), 597-609.

Zaoui, C., Overhage, J., Löns, D., Zimmermann, A., Müsken, M., Bielecki, P., Pustelny, C., Becker, T., Nimtz, M., & Häußler, S. (2012) An orphan sensor kinase controls quinolone signal production via MexT in *Pseudomonas aeruginosa*. *Molecular Microbiology* **83**(3), 536-547.

Dötsch, A., Eckweiler, D., Schniederjans, M., Zimmermann, A., Jensen, V., Scharfe, M., Geffers, R., & Häußler, S. (2012) The *Pseudomonas aeruginosa* transcriptome in planktonic cultures and static biofilms using RNA sequencing. *PLoS One* **7**(2), e31092.

Bielecki, P., Komor, U., Bielecka, A., Müsken, M., Puchalka, J., Pletz, M.W., Ballmann, M., Martins Dos Santos, V.A., Weiss, S., & Häußler, S. (2013) Ex vivo transcriptional profiling reveals a common set of genes important for the adaptation of *Pseudomonas aeruginosa* to chronically infected host sites. *Environmental Microbiology* **15**(2), 570-587.

Bielecki, P., Lukat, P., Hüsecken, K., Dötsch, A., Steinmetz, H., Hartmann, R.W., Müller, R., & Häußler, S. (2012) Mutation in elongation factor G confers resistance to the antibiotic argyrisin in the opportunistic pathogen *Pseudomonas aeruginosa*. *Chembiochem* **13**(16), 2339-2345.



Project Leader

Prof. Dr. Irene Wagner-Döbler

Research Group Microbial
Communication (KOM)
iwd@helmholtz-hzi.de

Microbial Communication

Secretion and detection of small chemical signalling molecules (termed quorum sensing) allows bacteria to adjust their physiology to the presence and density of their own and foreign bacterial species as well as to eukaryotic members of the community. It is important for biofilm formation and virulence and thus could be a new target for anti-infectives. We studied quorum sensing signalling cascades, developed antibacterial screens and investigated the mechanism of action of carolacton, a new biofilm inhibitor.

Fatricide in the caries bacterium *Streptococcus mutans*

Streptococci regulate genetic competence through a small autoinducer called “competence stimulating peptide”. Genetic competence is the ability to take up external free DNA and integrate it into the genome. It requires a complex protein machinery in the cell membrane, termed transformasome. Interestingly, quorum sensing simultaneously induces death of a fraction of the population, which thus provides nutrients and genetic material for its siblings, a phenomenon called fratricide. We were able to sort the population of *S. mutans* into

Fluorescence microscopy of a Streptococcus mutans reporter strain culture induced by the competence stimulating peptide showing fratricide. Green cells are induced by quorum sensing to become competent and to synthesize the green fluorescent protein; red cells are membrane damaged dead cells, and dark cells are silent – neither lysing nor induced. Figure: HZI

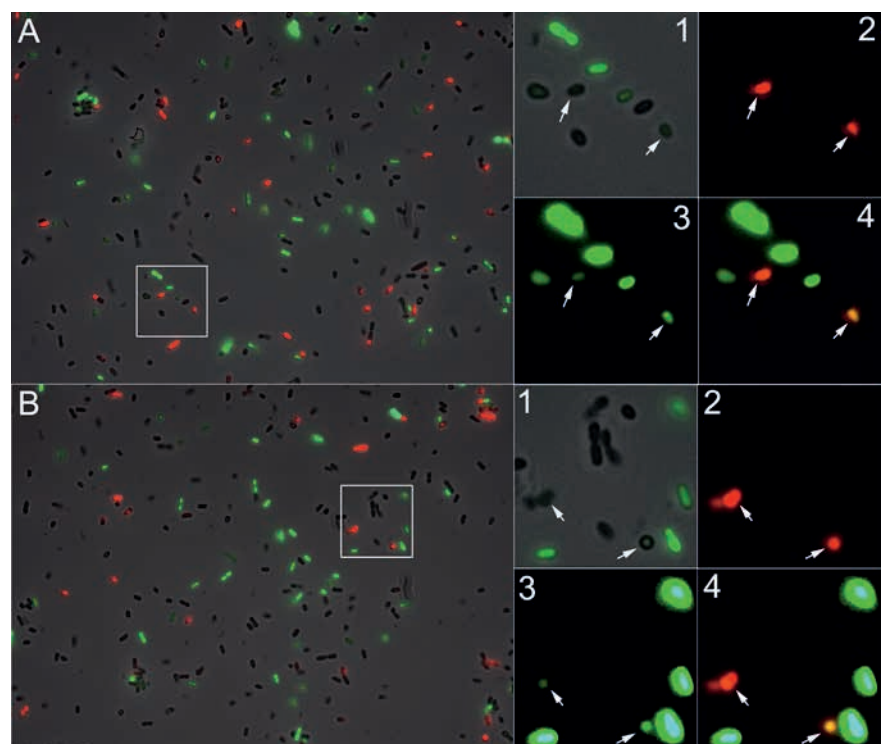

the induced and uninduced fractions using FACS (fluorescence activated cell sorting). To this end, a reporter strain was constructed which expressed the green fluorescent protein when quorum sensing was induced. The gene expression of the two different cell populations was analysed separately by microarray analysis and provided detailed insights into the regulation of competence and cell death.

Carolacton, a novel inhibitor of biofilm formation in *Streptococcus mutans*

Carolacton is a secondary metabolite which is produced by the soil bacterium *Sorangium cellulosum*. It inhibits biofilm formation of *Streptococcus mutans* at nanomolar concentrations. A study of its mechanism using time-resolved microarray analysis and knock-out of potential molecular targets showed that a novel protein kinase is essential for carolacton action, the serine-threonine protein kinase PknB (protein kinase B). It is present in monocopy in Streptococci and regulates cell division, but also modulates signalling through the two-component systems. These are the main interfaces for environmental adaptation in Streptococci. *S. mutans* has fourteen of them. The most important ones are Vi-cRK, which is the only essential one (*i.e.* it cannot be knocked out), and ComDE, which is induced by quorum sensing. Both of them are strongly affected by carolacton. Thus carolacton interferes with a signalling cascade important for growth, virulence and quorum sensing in *S. mutans*.



Project Members

Dr. Ina Buchholz, Dr. Brigitte Kunze,
Dr. André Lemme, Diana Patzelt,
Dr. Michael Reck, Thomas Riedel,
Dr. Helena Sztajer, Szymon Szafranski,
Dr. Jürgen Tomasch, Prof. Dr. Irene
Wagner-Döbler, Hui Wang, Corinna Wolf,
Dr. Xiaoli Xue

Publications

Lemme, A., Gröbe, L., Reck, M., Tomasch, J. & Wagner-Döbler, I. (2011) Subpopulation specific transcriptome analysis of CSP induced *Streptococcus mutans*. *Journal of Bacteriology* **193**(8),1863-1877

Reck, M., Rutz, K., Kunze, B., Tomasch, J., Surapaneni, S. S., Schulz, S. & Wagner-Döbler, I. (2011) The biofilm inhibitor carolacton disturbs membrane integrity and cell division of *Streptococcus mutans* through the serine-threonine protein kinase PknB. *Journal of Bacteriology* **193**(20), 5692-5706.

Xue, X., Sztajer, H., Buddrus, N., Petersen, J., Rohde, M., Talay, S.R., & Wagner-Döbler, I. (2011) Lack of the Delta Subunit of RNA Polymerase Increases Virulence Related Traits of *Streptococcus mutans*. *PLoS One* **6**(5), e20075.

Brinkhoff, T., Fischer, D., Vollmers J., Voget, S., Beardsley, C., Thole, S., Musmann, M., Kunze, B., Wagner-Döbler, I., Daniel, R., & Simon, M. (2011) Biogeography and phylogenetic diversity of a cluster of exclusively marine myxobacteria. *ISME Journal* **6**(6), 1260-1272

Song, L., Sudhakar, P., Wang, W., Conrads, G., Brock, A., Sun, J., Wagner-Döbler, I., & Zeng, A.-P. (2012) A genome-wide study of two-component signal transduction systems in eight newly sequenced mutans streptococci strains. *BMC Genomics* **13**,128.



Project Leader

Prof. Dr. Dirk Heinz

Department of Molecular Structural Biology
(MOSB)

dirk.heinz@helmholtz-hzi.de

Structural Analysis of Virulence Factors

Using X-ray crystallography we determine the atomic structures of biomacromolecules (like proteins or nucleic acids) involved in bacterial and viral infection processes and the biosynthesis of natural compounds.

Virulence Factors in Bacterial and Viral Infections

Pathogens often rely on thermosensing to adjust their virulence gene expression. In *Yersinia enterocolitica*, the transcriptional master regulator RovA control its own activity by a built-in thermosensor. Inside warm-blooded hosts, RovA undergoes conformational changes that attenuate DNA binding making the protein prone to proteolysis. In cooperation with the Dersch group we solved the structure of free and DNA-bound RovA and found that a loop in the dimerization domain and residues in the adjacent C-terminal helix being prone to unfolding at 37 °C. This structural distortion is relayed to the flexible DNA-binding domain leading to the release of RovA from its operator sites and to RovA's subsequent degradation. In contrast to RovA, SlyA, a close homologue from *Salmonella*, is active and stable at 37 °C. Adapting RovA to SlyA by site-directed mutagenesis results in the complete abolishment of RovA's thermosensing properties.

Hepatitis C virus (HCV) NS3-4A protease is essential for viral replication. In cooperation with the Collins group we solved the structure of NS3-4A in complex with novel inhibitory peptides that have been obtained from phage display. The peptides bind to an alternative site in the protease via a novel "tyrosine finger" making them interesting for further HCV drug development. Due to a combination of geometrical constraints and to the impairment of the oxyanion hole the peptides resist cleavage by the active site. Optimization through combinato-

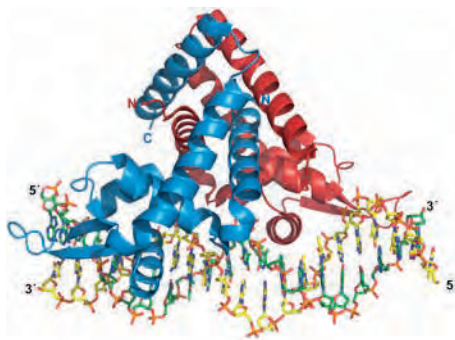
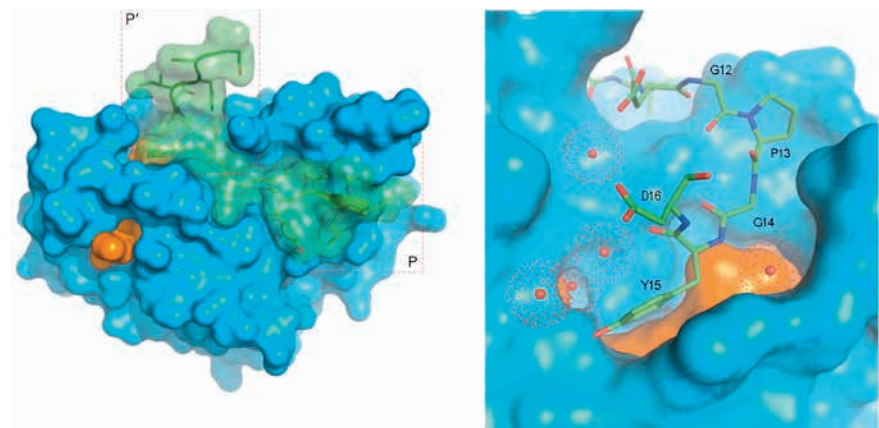

Fig. 1. RovA in complex with DNA.

Figure: HZI

Fig. 2. Left: NS3-4A in complex with peptide inhibitor. Right: Detailed view of tyrosine finger in alternative binding pocket.

Figure: HZI



rial phagemid display and protein crystallography resulted in a 32-amino acid peptide that proved to be a potent inhibitor of viral replication in cell culture and was able to inhibit frequent resistance mutants of NS3-4A.

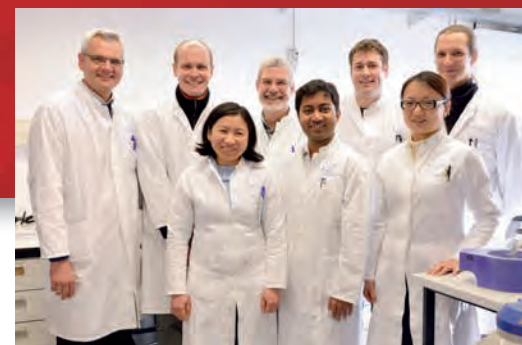
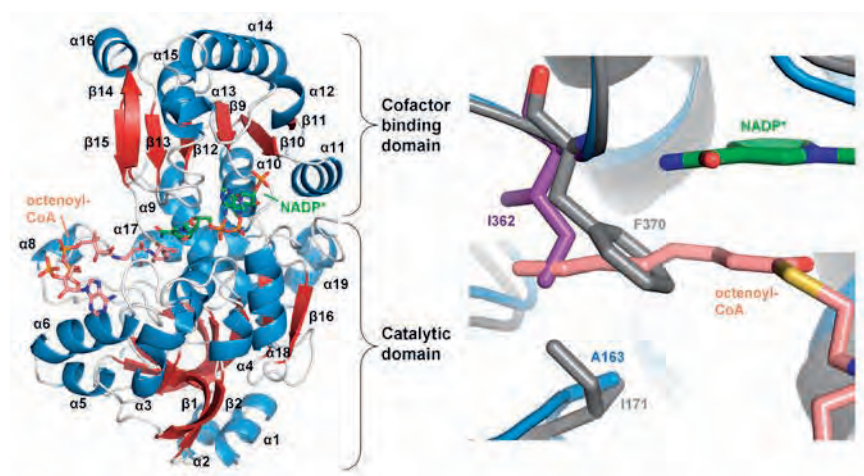

Project Members

Andrea Berger, Thomas Heidler, Prof. Dr. Dirk Heinz, Dr. Jörn Krauß, Wei Li, Sally Pham, Nick Quade, Dr. Joachim Reichelt, Sayantan Saha, Dr. Stefan Schmelz

Chemical Diversity of Natural Compounds

Polyketides are structurally diverse, medically important molecules showing various biological activities. During their biosynthesis, chain elongation uses diverse building blocks, the availability of which limits the variation of the polyketide side chains. Enzymes belonging to the crotonyl-CoA carboxylase/reductase (CCR) class can, in theory, form building blocks with any side chain from unsaturated fatty acid precursors. In cooperation with the Müller group we determined the first crystal structure of a CCR, the hexylmalonyl-CoA synthase CinF from *Streptomyces*, in complex with its substrate. Structural and biochemical analysis of CinF revealed how primary metabolic CCRs can evolve to produce new building blocks and set the stage for the design of altered polyketides with new properties (s. also Highlights: Review by Dirk Heinz & Rolf Müller “New options for rational biosynthetic engineering”).

Tetrapyrroles are among the compounds most crucial for life on Earth. In a long-standing cooperation with D. Jahn and J. Moser (TU Braunschweig) we study the structure of enzymes involved in heme and chlorophyll biosynthesis. Multi-subunit DPOR is a nitrogenase-like enzyme that catalyzes the two-electron reduction of protochlorophyllide a. It thereby alters the absorption properties of this molecule and provides the basis of photosynthesis. We solved the structure of substrate-bound DPOR trapped in transition state. Our analysis permitted investigation of the dynamic interplay between the DPOR subunits and led to a deeper understanding of electron transfer mechanisms of multiprotein complexes.

Fig. 3. Left: Domain organization of the CinF monomer. Right: Comparison of CinF active site with those of other CCR's (modeled) illustrating the criterion for side chain size of the building blocks synthesized.

Figure: HZI

Fig. 4. DPOR holo-complex with protochlorophyllide a and ADP-aluminium fluoride.

Figure: HZI

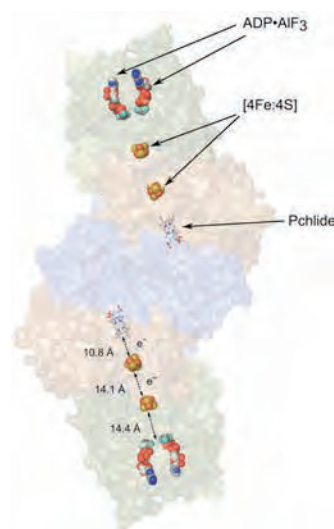

Publications

Quade, N., Mendonca, C., Herbst, K., Heroven, A.K., Ritter, C., Heinz, D.W., & Dersch, P. (2012) Structural basis for intrinsic thermosensing by the master virulence regulator RovA of *Yersinia*. *Journal of Biological Chemistry* **287**, 35796-35803.

Kügler, J., Schmelz, S., Gentsch, J., Haid, S., Pollmann, E., van den Heuvel, J., Franke, R., Pietschmann, T., Heinz, D.W., & Collins, J. (2012) High affinity peptide inhibitors of the hepatitis C virus NS3-4A protease refractory to common resistant mutants. *Journal of Biological Chemistry* **287**, 39224-39232.

Quade, N., Huo, L., Rachid, S., Heinz, D.W., & Müller, R. (2011) Unusual carbon fixation gives rise to diverse polyketide extender units. *Nature Chemical Biology* **8**, 117-124.

Storbeck, S., Saha, S., Krausz, J., Klink, B.U., Heinz, D.W., & Layer, G. (2011) Crystal structure of the heme d1 biosynthesis enzyme NirE in complex with its substrate reveals new insights into the catalytic mechanism of S-adenosyl-L-methionine-dependent uroporphyrinogen III methyltransferases. *Journal of Biological Chemistry* **286**, 26754-26767.

Moser, J., Lange, C., Krausz, J., Rebele, J., Schubert, W.D., Ribbe, M.W., Heinz, D.W., & Jahn, D. (2013) Structure of ADP-aluminium fluoride-stabilized protochlorophyllide oxidoreductase complex. *Proceedings of the National Academy of Sciences USA* **110**, 2094-2098.



Project Leader

Dr. Thorsten Lührs

Junior Research Group Structure-Based
Infection Biology (SBIB)
thorsten.luehrs@helmholtz-hzi.de

Structural Biology of Viral Persistence and Mammalian Prions

Viruses are obligate intracellular parasites and rely on cellular resources for their propagation. Viruses that remain in the host for a prolonged period of time face particular challenges. Their survival and replication depend on a fine balance between opsonized cellular pathways and resources to produce viral progeny. For example, the life-cycle of herpes viruses is characterized by two phases: lytic replication and latency. The cellular machinery is then hijacked to replicate the viral dsDNA episome. The molecular structural mechanism that controls herpes viral latency and also the interactions with host-derived co-factors might provide useful targets for antiviral therapeutic intervention.

Structure and Function of KSHV LANA (kLANA).

(A) The 3D structure of the C-terminal DNA binding domain was solved by X-ray crystallography (PDB database entries 2YPY, 2YPZ, 2YQ0, 2YQ1). kLANA tends to form higher order oligomers and the perturbation of the oligomerization interface abolishes LANA-speckle formation, in vivo. (B) The interaction interfaces of kLANA and human BRD2 ET Domain were mapped to the protein surfaces by NMR-spectroscopy using chemical shift perturbation.

Figure: HZI

In contrast to viruses and viroids, the prions are a unique class of pathogens, which are thought to propagate exclusively as self-templating protein conformations. In the associated human and non-human infectious neurodegenerative diseases, the mammalian prion protein PrP^C, switches its conformation into an aggregated transmissible prion state, PrP^{Sc}. Once a prion is introduced into a susceptible host, it triggers a PrP conversion cascade, which leads to prion disease (Fig. 1A). Understanding the underlying molecular mechanism of prions might provide conceptual advances to understand other forms of human neurodegenerations, including Alzheimer's disease and Parkinson's disease.

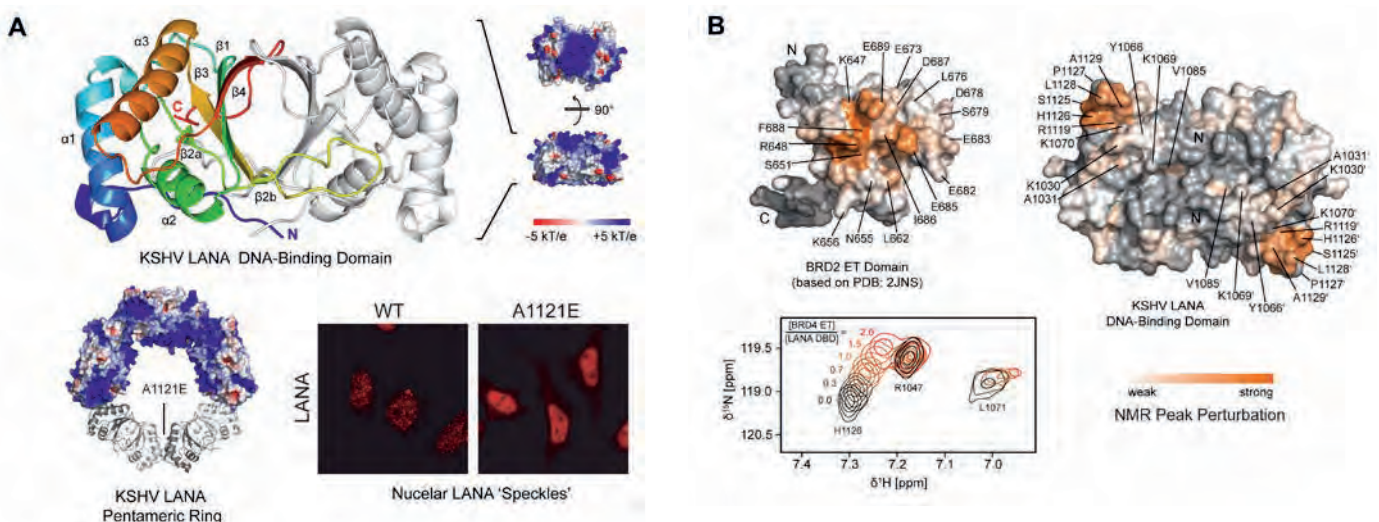

Herpes viral persistence

Kaposi's Sarcoma Associated Herpes virus (KSHV) is a γ_2 herpes virus that infects endothelial cells and B cells. It is associated with several malignancies. Murine herpes virus 68 (MHV-68) is a related γ_2 -herpes virus frequently used as a model to study the biology of γ -herpes viruses *in vivo*. The KSHV latency-associated nuclear antigen (kLANA) and the MHV68 mLANA (orf73) protein are required for latent viral replication and persistence. Latent episomal KSHV genomes and kLANA form nuclear microdomains, termed 'LANA speckles', which also contain cellular chromatin proteins. We solved the X-ray crystal structure of the C-terminal DNA binding domains (CTD) of kLANA (Fig. 1A) and MHV-68 mLANA. Opposite to the DNA binding site, both kLANA and mLANA CTD contain a characteristic lysine-rich positively charged surface patch, which appears to be a unique feature of γ_2 -herpes viral LANA proteins. Importantly, kLANA and mLANA CTD dimers undergo higher order oligomerization (Fig. 1A). Using NMR spectroscopy we identified a specific binding site for the host-derived ET domains of BRD2/4 on kLANA (Fig. 1B). Functional studies employing multiple kLANA mutants indicate that the oligomerization of native kLANA CTD dimers, the characteristic basic patch and the ET binding site on the kLANA surface are required for the formation of kLANA 'nuclear speckles' and latent replication. Similarly, the basic patch on mLANA contributes to the establishment of MHV-68 latency in spleen cells *in vivo*. In summary, our data provides a structural basis for the formation of higher order LANA oligomers, which is required for nuclear speckle formation, latent replication and viral persistence.

Prions

Interspecies transmission barriers have been observed to correlate with the amino acid sequence of PrP. On the other hand, multiple prionstrains of the same PrP amino acid sequence have been identified that cause characteristic pathologies in one host species. We aim to investigate prion 3D structures in order to understand the transmission barrier between mice and hamsters at atomic resolution, and to understand the structural basis of prion strains in relation to prion host range. We employ a combination of solution NMR, solid state NMR, and other biophysical techniques in order to obtain initial structural information of these aggregates. A key technique in achieving our research goals is the conversion of isotopically labelled recombinant PrP^C into PrP^{Sc}. Therefore, we have invented a novel technology for the *in vitro* generation of specific amyloid-like aggregated prion conformations starting from prion infected brain tissue. The approach might be extended for the basic investigation of other neurodegenerative disorders like Alzheimer's disease and Parkinson's disease.



Project Members

Jan Hellert, Vandana Gupta,
Dr. Thorsten Lühns, Neda Tafirishi

Publications

Hellert, J., Weidner-Glunde, M., Krausze, J., Richter, U., Adler, H., Fedorov, R., Pietrek, M., Rückert, J., Ritter, C., Schulz T.F., & Lühns, T. (2013) A Structural Basis for BRD2/4-Mediated Host Chromatin Interaction and Oligomer Assembly of Kaposi Sarcoma Herpesvirus and Murine Gammaherpesvirus LANA proteins, *PLoS Pathogens*, in press.



Project Leader

Prof. Dr. Christiane Ritter

Helmholtz University Junior Research Group
Macromolecular Infections (MMIA)
christiane.ritter@helmholtz-hzi.de

Structural and Mechanical Analysis of Functional Amyloids

Bacterial fibrillar adhesins with an amyloid-like fold have recently been identified as a novel class of adhesins that are expressed by many Gram-positive and Gram-negative bacteria. A study on biofilms from different habitats established that up to 40% of the bacteria present within these communities carry amyloid-like fibrils on their surface. They have been identified as virulence traits important for biofilm formation, interaction with host proteins and promoting survival in a wide range of conditions. Amyloid-like fibrils are ordered aggregates that have a high content of specific beta-sheet secondary structure. Long associated with human diseases such as Alzheimer's disease, Parkinson's disease and Creutzfeld-Jacob disease, the amyloid fold is now known to be formed natively by a large set of diverse proteins without toxic side-effects.

The major focus of our group lies on the determination of the structural and mechanical basis of these functions for selected bacterial and fungal amyloids.

Tools for the structure determination of amyloid fibrils

The size and non-crystalline nature of fibrillar protein assemblies drastically restrict the use of established structural techniques. We therefore employ quenched hydrogen exchange measured by nuclear magnetic resonance (NMR) and solid state NMR to study the structure and function of this important class of proteins. Solid-state NMR is a new method to determine high-resolution structures of insoluble protein assemblies. We have therefore established this technique at the HZI and now possess a custom-made, unique set-up that is also suitable to study infectious protein samples. In addition, we develop biochemical tools to generate protein samples with selective isotope labelling patterns.

E. coli bacteria connected by a network of adhesive Curli fibrils. Image: Manfred Rohde



Curli: an amyloid coat that increases bacterial virulence

Curli is the major proteinaceous component of the extracellular matrix produced by *Enterobacteriaceae* such as *E. coli* and *Salmonella typhimurium*. Curli fibrils are involved in the adhesion to biotic and abiotic surfaces and the promotion of biofilm formation. They also interact with several host proteins, resulting in increased tissue penetration, inflammation and sepsis. *In vivo*, curli biogenesis is dependent on the nucleation of the major curli component, CsgA, by the homologous protein CsgB. In order to understand the features responsible for

the different functionalities of CsgA and CsgB, we have analysed the structures, aggregation kinetics and thermodynamic stabilities of the fibrils formed by both proteins. In addition, we analyze the structure and function of chaperones that are essential for curli biogenesis *in vivo*. A mechanistical understanding of curli biogenesis will allow us to identify new ways to interfere with fibril formation in order to reduce bacterial virulence.

HET-s: a functional prion found in filamentous fungi

Only a subset of amyloids are self-propagating prions. To understand the molecular determinants that govern the infectivity of an amyloid, we investigate the biophysical properties of the functional prion protein HET-s from the filamentous fungus *Podospora anserina*, and of a recently identified homolog from *Fusarium graminearum*. Despite limited sequence identity, the amyloid fibrils formed by both proteins can cross-seed each other, i.e. they are able to breach the species barrier. Using quenched hydrogen exchange NMR, we could explain this observation with a high structural similarity of the amyloid fibrils.

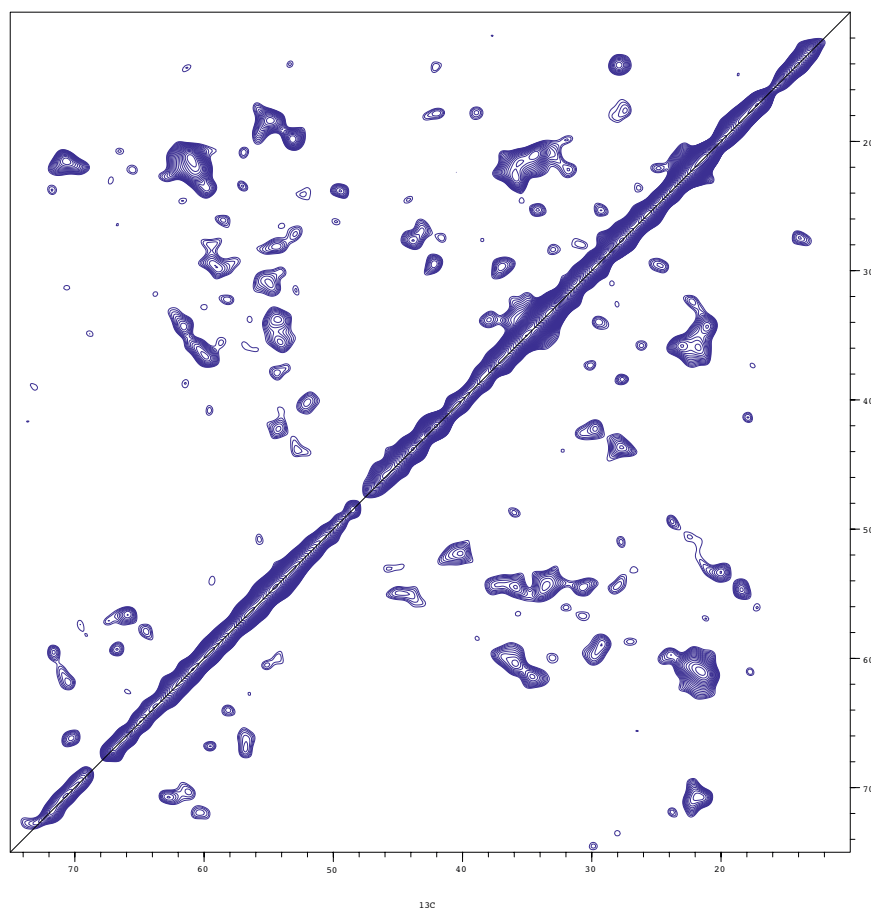

Project Members

Dr. Mumdooh Ahmed, Madhu Nagaraj, Prof. Dr. Christiane Ritter, Johannes Spehr, Tobias Schubeis

Solid state NMR spectrum of the prion-forming domain of HET-s, showing correlations between carbon atoms. Figure: HZI

Publications

Hellert, J., Weidner-Glunde, M., Krausze, J., Richter, U., Adler, H., Fedorov, R., Pietrek, M., Rückert, J., Ritter, C., Schulz T.F., & Lührs, T. (2013) A Structural Basis for BRD2/4-Mediated Host Chromatin Interaction and Oligomer Assembly of Kaposi Sarcoma Herpesvirus and Murine Gammaherpesvirus LANA proteins, *PLoS Pathogens*, in press.

Wasmer, C., Zimmer, A., Sabate, R., Soragni, A., Saupe, S.J., Ritter, C., & Meier, B.H. (2010) Structural Similarity between the Prion Domain of HET-s and a Homologue Can Explain Amyloid Cross-Seeding in Spite of Limited Sequence Identity. *Journal of Molecular Biology* **402**(2), 311-325.

Greenwald, J., Buhtz, C., Ritter, C., Kwiatkowski, W., Choe, S., Maddelein, M.L., Ness, F., Cescau, S., Soragni, A., Leitz, D., Saupe, S.J., & Riek, R. (2010) The Mechanism of prion inhibition by HET-S. *Molecular Cell* **38**, 889-899.

Ritter, C., Maddelein, M.L., Siemer, A.B., Luhrs, T., Ernst, M., Meier, B.H., Saupe, S., & Riek, R. (2005) Correlation of structural elements and infectivity of the HET-s prion. *Nature* **435**, 844-848.



Project Leader

Prof. Dr. Manfred Rohde

Department of Medical Microbiology (MMIK)
mro@helmholtz-hzi.de

Intracellular Trafficking, Survival and Persistence of Streptococci

Streptococcus pyogenes, Group A streptococcus (GAS), is the major cause of human streptococcal infections that range from uncomplicated to severe and life-threatening infections like necrotizing fasciitis. Besides GAS, also Group C and G streptococci (GCS, GGS), *S. dysgalactiae* subsp. *equisimilis* are common in invasive infections, especially in elderly persons. A hallmark of all streptococcal infections is that after a first episode of infection some patients experience recurrent infections like tonsillitis or erysipelas episodes- the carrier status of streptococci. Over the last years growing evidence has accumulated that recurrent infections may be attributed to streptococcal subpopulations in the patient which i) remain bound to extracellular matrix proteins like collagen or ii) due to intracellular persistence, therefore, avoiding the effect of antibiotic treatment and the onset of the host immune system. For intracellular persistence, streptococci have developed a battery of proteins for adhesion and invasion into host cells.

Invasion and survival mechanisms

Fibronectin-binding proteins of streptococci play an important role in adherence and invasion. Especially the streptococcal fibronectin-binding protein I (Sfbl) and the GGS fibronectin-binding protein A (GfbA) have been studied in greater

Fig. 1. Summary of invasion and trafficking pathways of streptococci. Caveolae-mediated invasion leads to trafficking into, and survival, in caveosomes whereas invasion via cytoskeletal alterations leads to trafficking alongside the classical endocytic pathway with lysosomal fusion to form phagolysosomes and a reduced survival rate. Image: Manfred Rohde

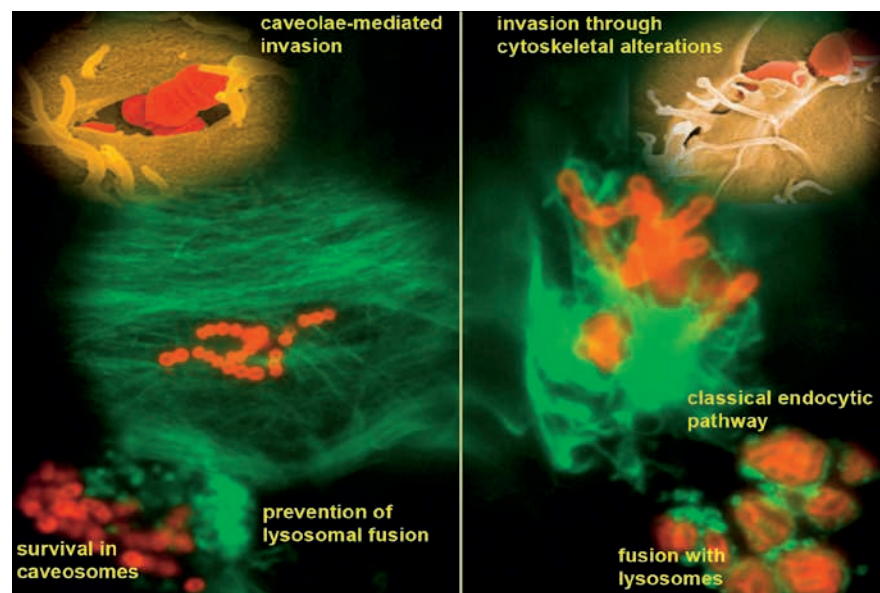

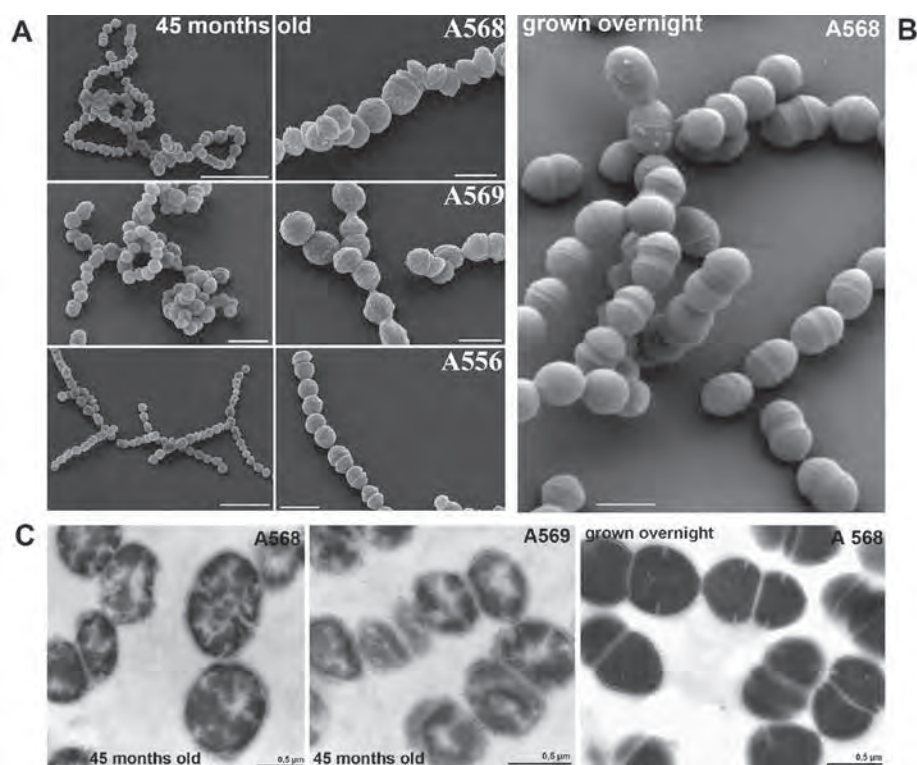

Project Members

Katja Branitzki-Heinemann,
Prof. Dr. Manfred Rohde

Fig. 2. *Streptococci* depicted after 45 months culture in TSB broth by field emission scanning EM (A and B). The scanning EM images reveal minor morphological differences between the 45-months old bacteria and overnight grown streptococci in TBS broth. In ultrathin sections (C) cell walls look very similar. In the 45-months old streptococci the dividing cell walls are clearly visible. The old streptococci exhibit a condensed cytoplasm and morphological alterations in the DNA regions (white areas). Bars represent 1 μm in A and B.

Image: Manfred Rohde

detail. Two major invasion mechanisms of GAS, GGS and other streptococci have been elucidated so far, i) invasion via cytoskeletal rearrangements by triggering signalling cascades in the host cell and ii) invasion via large invaginations formed by the fusion of caveolae mediated by SfbI. Our studies aimed to elucidate the trafficking pathways inside the host cells. The results revealed that all streptococci invading via cytoskeletal rearrangements follow the intracellular classical endocytic pathway with subsequent fusion with lysosomes to form phagolysosomes. Due to the binding of fibronectin to SfbI and subsequent binding to and clustering of integrins SfbI expressing GAS co-opt host caveolae and reside inside caveosomes. Therefore, they are preventing fusion with the cellular degrading mechanisms via lysosomes. This contributes to better survival inside the host cells in the cell culture model (see Fig. 1).

For survival of streptococci in nutrient broth only scarce information is available. To shed light onto possible survival times in nutrient broth we cultivated GAS in TSB broth for 45 months and examined the streptococcal morphology. As is evident from Fig. 2 the 45-months old streptococci were morphological identical to those grown overnight after inoculating TSB with 5 μl of the 45-months old streptococcal pellet when examined by scanning EM. Only ultrathin sections revealed major structural differences in the cytoplasm of streptococci between 45-months old and freshly grown TSB cultures. These results suggest that streptococci can persist for a long time inside the human body and are able to cause recurrent infections in very short times when the environmental circumstances for growth are optimal.

Publications

Rohde, M., Talay, S.R., & Rasmussen, M. (2012) Molecular mechanisms of *Streptococcus dysgalactiae* subsp. *equisimilis* enabling intravascular persistence. *Microbes and Infection* **14**, 329-334

Rohde, M., & Chhatwal, G.S. (2012) Adherence and Invasion of Streptococci to Eukaryotic Cells and their Role in Disease Pathogenesis. *Current Topics in Microbiology and Immunology*. Doi:10.1007/82_2012_281 [Epub ahead of print]

Henningham, A., Chiarot, E., Gillen, C.M., Cole, J.N., Rohde, M., Fulde, M., Ramachandran, V., Cork, A.J., Hartas, J., Magor, G., Djordjevic, S.P., Cordwell, S.J., Kobe, B., Sriprakash, K.S., Nizet, V., Chhatwal, G.S., Margarit, I.Y., Batzloff, M.R., & Walker, M.J. (2012) Conserved anchorless surface proteins as group A streptococcal vaccine candidates. *Journal of Molecular Medicine* **90**, 1197-1207.

Rohde, M., Graham, R.M., Branitzki-Heinemann, K., Borchers, P., Preuss, C., Schleicher, I., Zahner, D., Talay, S.R., Fulde, M., Dinkla, K., & Chhatwal, G.S. (2011) Differences in the aromatic domain of homologous streptococcal fibronectin-binding proteins trigger different cell invasion mechanisms and survival rates. *Cellular Microbiology* **13**, 450-468.

Amelung, S., Nerlich, A., Rohde, M., Spellerberg, B., Cole, J.N., Nizet, V., Chhatwal, G.S., & Talay, S.R. (2011) The FbaB-type fibronectin-binding protein of *Streptococcus pyogenes* promotes specific invasion into endothelial cells. *Cellular Microbiology* **13**, 1200-1211.



Project Leader

Priv.-Doz. Dr. Manfred Höfle

Research Group Microbial Diagnostics (MIDI)
mho@helmholtz-hzi.de

Molecular Diagnostics of Microbial Pathogens

Major infection routes for microbial pathogens from the environment are drinking water, food and air. Water and food are primary sources of diarrheal infections whereas air is the major source of respiratory infections. To cover all major environmental infection routes, specific parts of the environment functioning as reservoirs were considered and relevant pathogens were studied.

Coastal marine environments as reservoir of *Vibrio cholerae*

There is a considerable global effort to reduce the risk of *Vibrio* infections and yet in many countries, illnesses associated with these bacteria are increasing. We used historical samples from the continuous plankton recorder (CPR) archive in Plymouth, UK, to demonstrate that the genus *Vibrio*, including the human pathogen *V. cholerae*, has increased in prevalence during the last 50 years

Epifluorescence microscopy of the pathogenic yeast Candida albicans (blue cells) infecting human lung epithelia (green cells)

Figure: Rolf Kramer, HZI

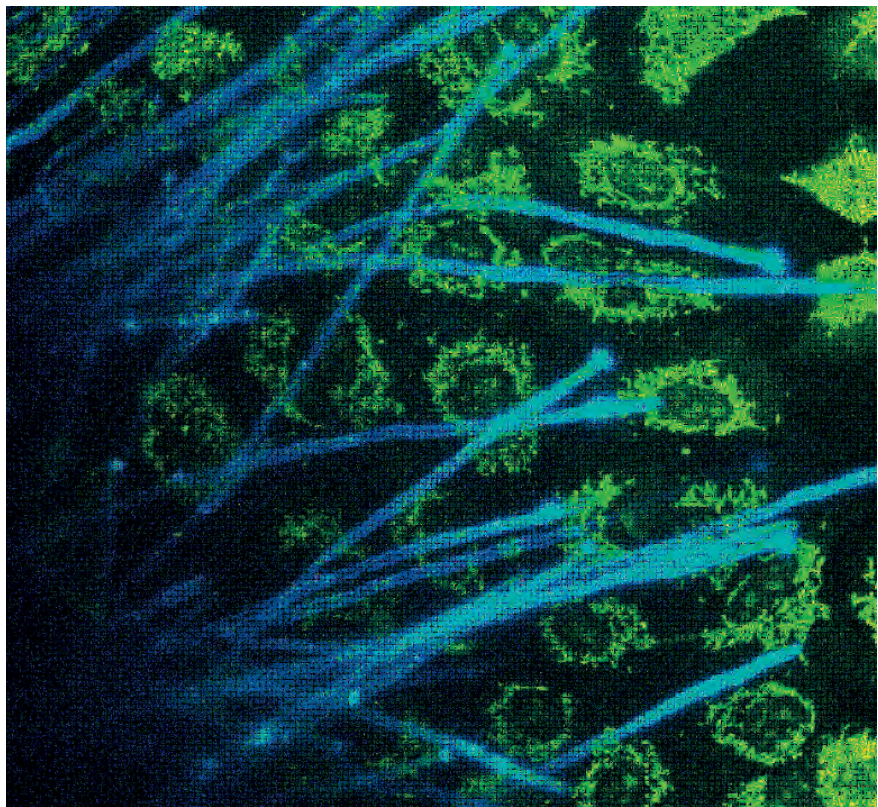

in the coastal waters of the southern North Sea. This increase was correlated significantly with increasing sea surface temperature during the same period. Global warming may have a strong impact on the composition of the marine bacterial community with important implications for human health.

Environmental reservoirs of waterborne pathogens in drinking water

There is a rather limited knowledge on the microbiological principles governing the prevalence of microbial pathogens in drinking water. Drinking water distribution systems (DWDS) provide two very different types of habitats for bacteria: bulk water and adjacent biofilms. Biofilms are present in every DWDS attached to the surface of tubing materials. We studied the bacterial core community of bulk water and corresponding biofilms of a more than 20 year old DWDS providing drinking water to the HZI. The structure and composition of the bacterial core community in the bulk water was highly similar across sampling sites whereas all biofilm samples contained unique communities with very little overlap with species from bulk water. All biofilm communities showed higher relative abundances of individual bacterial species and a reduced richness compared to bulk water.

An infectious disease with increasing relevance for developed countries is legionellosis which is freshwater-based but caused by inhaled aerosol droplets containing pathogenic *Legionella* species. Therefore, these species could also be regarded as airborne pathogens. We studied the occurrence of different *Legionella* species in cold and hot drinking water using genus-specific molecular fingerprints. We could demonstrate that the treatment of the raw water reduced some of the *Legionella* species and increased others. In hot drinking water *L. pneumophila* was abundant all year round whereas in cold drinking water it only occurred during winter.

Airborne pathogens in cystic fibrosis patients

Airborne pathogens cause by far the most relevant human infections with influenza pandemics being only the tip of the iceberg. The resulting infections are often characterized by successions of a primary viral infection followed by secondary bacterial infections. This polymicrobial nature makes these infections difficult to diagnose and treat in an appropriate manner. As an example for polymicrobial infections, we studied sputum samples from the cystic fibrosis (CF) cohort of the Medical School Hannover. These samples were analyzed by universal bacterial fingerprints leading to a comprehensive assessment of the bacterial content of the sputum. Interestingly, a single bacterial species often dominated the sputum and these dominant bacteria belonged to several pathogenic species. This universal bacterial detection was complemented by a universal fungal detection fingerprint. Interestingly, we could show that the fungal diversity in the sputum of the whole cohort studied was about twice as high (60 species) than the bacterial diversity. This combined approach for fungal-bacterial diagnostics now provides an efficient tool to obtain novel insights into polymicrobial lung infections.



Project Members

Dr. Ingrid Brettar, Priv.-Doz. Dr. Manfred Höfle, Rolf Kramer, Rene Lesnik, Douglas Mushi, Marina Pecellin, Rui Pereira

Publications

Brettar, I., Christen, R., & Höfle, M.G. (2012) Analysis of bacterial core communities in the central Baltic by comparative RNA-DNA-based fingerprinting provides links to structure-function relationships. *ISME Journal* **6**, 195-212.

García, K., Gavilán, R.G., Höfle, M.G., Martínez-Urtaza, J., & Espejo, R.T. (2012) Microevolution of pandemic *V. parahaemolyticus* assessed by the number of repeat units in short sequence tandem repeats regions. *PLoS One* **7**, e30873.

Henne, K., Kahlisch, L., Brettar, I., & Höfle, M.G. (2012) Analysis of structure and composition of bacterial core communities in mature drinking water biofilms and bulk water of a citywide network in Germany. *Applied and Environmental Microbiology* **78**, 3530-3538.

Kahlisch, L., Henne, K., Gröbe, L., Brettar, I., & Höfle, M.G. (2012) Assessing the species composition of viable bacteria in drinking water using Fluorescence Activated Cell Sorting (FACS) and community fingerprinting. *Microbial Ecology* **63**, 383-397.

Vezzulli, L., Brettar, I., Pezzati, E., Reid, P.C., Colwell, R.R., Höfle, M.G., & Pruzzo, C. (2012) Long-term effects of ocean warming on the prokaryotic community: evidence from the vibrios. *ISME Journal* **6**, 21-30.



Project Leader

Prof. Dr. Lothar Jänsch

Research Group Cellular Proteomics (CPRO)

lothar.jaensch@helmholtz-hzi.de

Analysis of Protein Networks Induced by Early Host-Pathogen Interactions

The Research Group Cellular Proteomics focuses on the analysis of host signalling pathways involved in early events of infectious processes in humans and the host's adaptive immune responses towards pathogens. Modules for cell biological, biochemical, mass spectrometric and bioinformatic approaches have been developed and combined for this purpose. Our aim: a quantitative and time-resolved characterization of novel potential drug targets and mechanisms of post-translational modifications (PTMs) in tissues as well as primary and immortalised human cells.

Quantitative peptide sequencing by accurate mass spectrometry facilitates the identification of cellular „target proteins“ and the understanding of signalling networks. Immobilised small molecules are used as „baits“ to enrich and analyse the activities of signalling components. These, combined with chromatographic and mass spectrometric methods, enable analyses of transient modifications on signalling components. In case of phosphorylations this refers

Dynamics of immunological synapse (IS) formation of NK cells that recognize target cells. The Ca²⁺-binding protein S100A6 (red) colocalizes with Myosin IIa (green) and is transiently recruited into the IS as visualized in the merged color channels (including DAPI, blue, for DNA). S100A6 is considered as a novel component of the IS and was identified based on comparative proteome analyses of primary human NK cell subsets. Photo: HZI

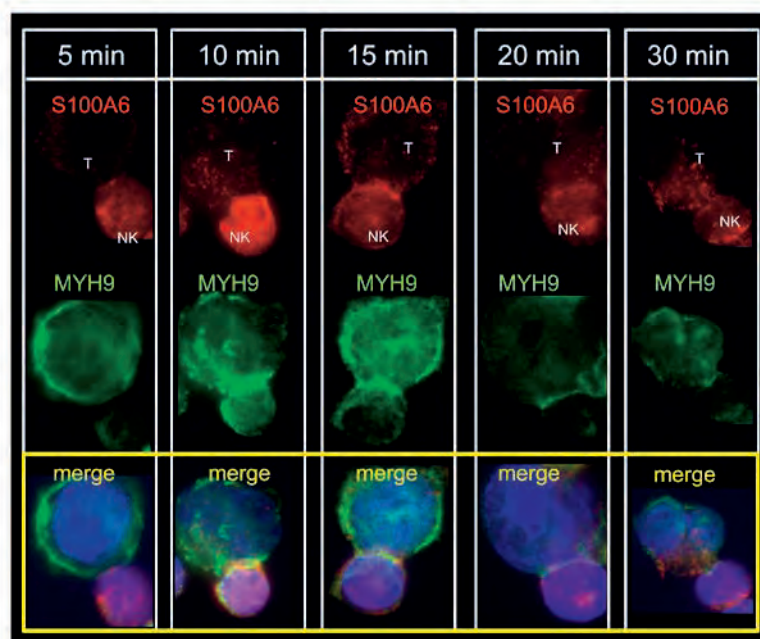

to protein kinases, *i.e.* their activities and molecular interactions with substrate molecules. iTRAQ™-technology is used for quantitative peptide sequencing and iTRAQassist for statistical evaluations, both matching the quality criteria for clinical studies based on tissues and primary cells.

MET signalling pathways during invasion by *Listeria monocytogenes*

The bacterial pathogen *L. monocytogenes* causes severe illnesses and pre-natal infections. The virulence factor InlB interacts with the receptor tyrosine kinase c-Met and induces its endocytosis and thus the uptake of the pathogen into host cells. The signalling pathways involved are controlled through protein phosphorylations by kinases as well as (de)ubiquitinations. The first minutes of kinase-dependent signal transduction were analysed for this pathway for the first time. We identified signalling components involved in listerial invasion that were not described for the c-Met pathways activated by the physiological ligand, HGF. Functional investigations of these kinases thus determine their contribution to the invasion as well as to motogenic and mitogenic processes. Indications for counter-regulation of this invasion pathway were obtained from analyses of human ubiquitin proteases (DUBs) whose activities are influenced by *Listeria*.

Signalling pathways involved in activation of NK and regulatory T cells

T lymphocytes are essential for regulating the immune system. The different cellular responses of conventional and regulatory T cells depend directly on the differential activation of such pathways. Comparative phosphokinome analyses of primary regulatory T cells detected novel components of the CD3/CD28-dependent activation pathways and microtubule-regulating proteins. Mechanisms of proximal signal integration were also analysed in natural killer (NK) cells within 2 minutes after activation. NK cells are part of the innate immune response and interact through the immunological synapse (IS) with virus-infected cells. A donor-specific analysis of their maturation led to the identification of novel IS components. The characterization of general mechanisms guiding microtubule-dependent processes within the IS constitutes a new research focus. Of particular interest are investigations of the regulation of tubulin tyrosine ligase that coordinates the recruitment of intracellular motor proteins.

In summary, the elucidation of early signalling events in host endothelial and immune cells following interaction with pathogens will provide insights into regulatory networks leading to the identification of novel targets for therapeutic intervention.



Project Members

Nada Abidi, Björn Bulitta, Prof. Dr. Lothar Jänsch, Dr. Marco van Ham, Kirstin Jurrat, Dr. Uwe Kärst, Prof. Dr. Frank Klawonn, Anne Kummer, Dr. Manfred Nimtz, Maxi Scheiter, Mario Schmidt, Dr. Olga Shevchuk, Dr. Lisette Wirsing, Dr. Josef Wissing

Publications

Scheiter, S., Lau, U., van Ham, M., Bulitta, B., Gröbe, L., Garritsen, H., Klawonn, F., König, S., & Jänsch, L. (2013) Proteome Analysis of Distinct Developmental Stages of Human Natural Killer Cells. *Molecular & Cellular Proteomics*, in press.

König, S., Probst-Kepper, M., Reinl, T., Jeron, A., Huehn, J., Schraven, B., & Jänsch, L. (2012) First insight into the kinome of human regulatory T cells. *PLoS One* **7**(7), e40896.

Iphöfer, A., Kummer, A., Nimtz, M., Ritter, A., Arnold, T., Frank, R., van den Heuvel, J., Kessler, B.M., Jänsch, L., & Franke, R. (2012) Profiling ubiquitin linkage specificities of deubiquitinating enzymes with branched ubiquitin isopeptide probes. *ChemBioChem* **13**(10), 1416-1420.

König, S., Nimtz, M., Scheiter, M., Ljunggren, H.G., Bryceson, Y.T., & Jänsch, L. (2012) Kinome analysis of receptor-induced phosphorylation in human natural killer cells. *PLoS One* **7**(1), e29672.

Reinl, T., Nimtz, M., Hundertmark, C., Johl, T., Kéri, G., Wehland, J., Daub, H. & Jänsch, L. (2009) Quantitative phosphokinome analysis of the Met pathway activated by the invasin InlB from *Listeria monocytogenes*. *Molecular & Cellular Proteomics* **8**(12), 2778-2795.



Project Leader

Prof. Dr. Frank Klawonn

Research Group Cellular Proteomics (CPRO)
frank.klawonn@helmholtz-hzi.de

Bioinformatics and Statistics: Statistical Evaluation of Functional Genomics and Proteomics Data

Cellular biomolecules are accessible by different high throughput technologies and are the target of systematic analyses in order to reveal the molecular workings of organisms, which is essential for understanding infection diseases and to find treatments against them.

Data analysis of high throughput experiments can provide novel and biological relevant hypotheses, but standard statistical approaches are often not suited for such data. The type (gene, RNA, protein, metabolite and number of molecular) of components contributing to the observed infection phenotypes are often unknown at the beginning of a project. We utilize methods from exploratory data analysis and data mining as well as corrections for multiple testing to handle such multivariate data sets and to reveal components actually involved in infection.

Standard statistical approaches fail to provide good models (blue curve) when a high proportion of noise is present (data on the left). Robust methods (green line) can handle such data better. This is an example from flow cytometry. Figure: HZI

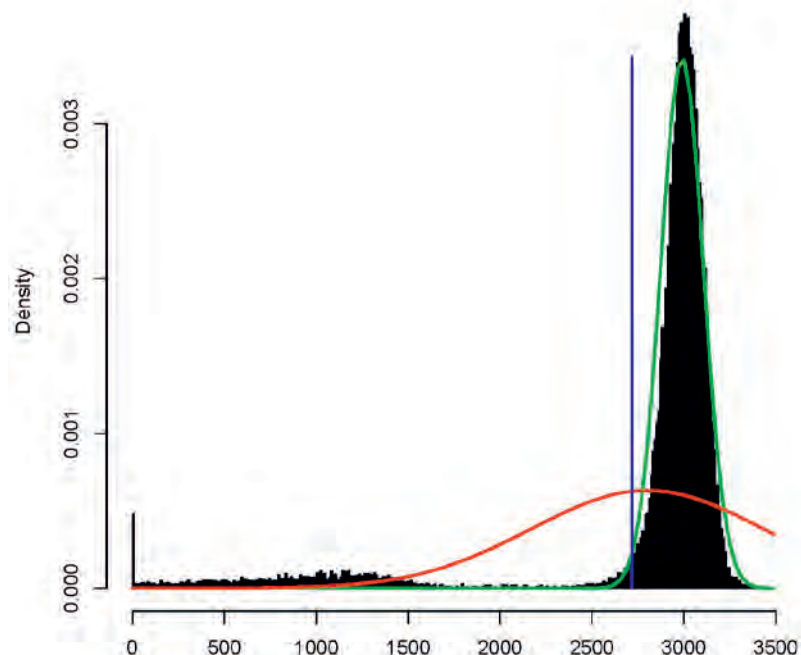

Raw data from technologies like mass spectrometry, microarrays, next generation sequencing or imaging technologies are naturally corrupted by noise. We provide special methods and noise models to distinguish biological effects from random fluctuations, especially for proteomics experiments, but also for other types of experiments.

Although the data sets from high throughput experiments themselves can be large, in most cases, few repetitions per experiment are available, leading to problems with classical statistical methods often based on larger sample sizes. Thus, a careful design of experiment as well as suitable statistical techniques are needed to generate reliable hypotheses in functional genome studies. Various approaches based on robust statistics and Bayesian inference have been developed to cope with these problems.

In summary, suitable data analysis techniques and statistical methods are essential for the analysis and evaluation of data from high throughput experiments to generate and test hypothesis in a reliable way. Our recent and future work focuses on data from time series experiments where the dynamics of the concentration of cellular biomolecules is observed over a period of time.



Project Members

Nada Abidi, Dr. Cristina Della Beffa,
Prof. Dr. Frank Klawonn

Publications

Berthold, M.R., Borgelt, C., Höppner, F., & Klawonn, F. (2010) Guide to Intelligent Data Analysis: How to Intelligently Make Sense of Real Data, Springer, London

Klawonn, F. (2012) Significance Tests to Identify Regulated Proteins Based on a Large Number of Small Samples. *Kybernetika* **48**, 478-493.

Wuestefeld, T., Pesic, M., Rudalska, R., Dauch, D., Longerich, T., Kang, T.-W., Yevsa, T., Heinzmann, F., Hoenicke, L., Hohmeyer, A., Potapova, A., Rittelmeyer, I., Jarek, M., Geffers, R., Scharfe, M., Klawonn, F., Schirmacher, P., Malek, N.P., Ott, M., Nordheim, A., Vogel, A., Manns, M.P., & Zender, L. (2013) A Direct *In Vivo* RNAi Screen Identifies MKK4 as a Key Regulator of Liver Regeneration. *Cell* **153**, 389-401.

Pommerenke, C., Müsken, M., Becker, T., Dötsch, A., Klawonn, F., & Häußler, S. (2010) Global Genotype-Phenotype Correlations in *Pseudomonas aeruginosa*. *PLoS Pathogens* **6**(8), e1001074. doi:10.1371/journal.ppat.1001074



Project Leader

Prof. Dr. Gérard Krause

Department of Epidemiology (EPID)
gerard.krause@helmholtz-hzi.de

Epidemiological Determinants for Viral and Bacterial Infections in Human Populations

Infectious disease research in humans carries the following imminent challenges: first, the risk to become infected is often dynamically linked to the extent by which other people in the environment are infectious; second, a large proportion of infections are inapparent; and third, infections may later result in non-communicable diseases. In order to overcome these challenges we are establishing special epidemiological methods to prospectively capture infections as they occur in healthy individuals. All our activities are intertwined with the project “Clinical outcomes of infectious diseases” (Mikolajczyk) and closely linked to the project “Molecular epidemiology of acute respiratory infections” (Pessler). Our joint attention is focussed on infectious diseases with high public health relevance.

Establishment of the National Cohort in Hannover/Braunschweig

We run one of 18 study centres of the National Cohort – the largest health research enterprise ever in Germany and one of the very few large cohort studies globally to simultaneously address infectious and non-communicable diseases. Our department coordinates all infection and immunity related issues in the National Cohort, in which a total of 200,000 participants will be re-examined periodically every 4 to 5 years for various decades. Our new study centre in Hannover has successfully completed the Pretest II in 2012.

The mucous membranes of the nose and mouth are colonised by complex bacterial and viral pathogens. Collecting swab samples is a painless method which makes the examination of a large number of study participants fairly easy. Various laboratory tests can be run on the collected swabs which provide valuable information on research questions pertaining to infectious diseases. HZI/Misiak



We have already conducted several feasibility studies of special infection-related modules. One example is the self collection of vaginal lavage by female participants to detect urogenital infections. This will enable us to study the effectiveness of a vaccine against human papilloma virus in preventing cervical cancer. After addition of further examination equipment and procedures, the National Cohort national pilot study will start in 2013.

Prevalence and persistence of Methicillin resistant *Staphylococcus aureus* (MRSA)

An increasing proportion of MRSA is being acquired not in the hospital but in the community and methicillin sensitive *Staphylococcus aureus* (MSSA) may be causing a higher burden of diseases than previously thought. We therefore conducted a population based study to measure prevalence of MRSA in the general population in Braunschweig and studied the persistence of MRSA-colonization in a longitudinal manner. We intend to expand this investigation to persons during, and after, hospital treatment and also to other cities in order to better understand the interaction between hospital and community based MRSA and MSSA.

Helicobacter pylori (HP)

HP is associated with gastric and possibly with intestinal cancer. The epidemiology of HP is very variable and different international groups are working on vaccines against HP. Within, and complementary to, the National Cohort we initiated epidemiological studies to generate evidence on how vaccinations and other measures could reduce the burden of HP related disease. For this purpose we are currently conducting a joint project with the German Center for Cancer Research (DKFZ) to establish methods of multiplex serology related to HP, which we later intend to expand to further pathogens.

Infections and associated metabolic diseases

Recent research indicates an increasing number of links between infections and metabolic diseases. Since the proposed causality mechanisms often require a long delay between infections and their metabolic consequences, studies in prospective cohorts are necessary and the National Cohort will provide the perfect research infrastructure to address this challenge.



Group at HZI



Group at Studienzentrum Hannover

Project Members

Dr. Manas Akmatov, Katrin Bohm,
Dr. Stefanie Castell, Johannes Horn
Dr. André Karch, Dr. Yvonne Kemmling,
Prof. Dr. Gérard Krause, Jaihsri Merhaj,
Prof. Dr. Rafael Mikolajczyk, Dr. Jördis
Ott, Heike Raupach-Rosin, Dr. Anja
Schultze, Dr. Claudia Sievers,
Dr. Aparna Schweitzer, Beate Zoch

Publications

Suess, T., Remschmidt, C., Schink, S.B., Schweiger, B., Nitsche, A., Schroeder, K., Doellinger, J., Milde, J., Haas, W., Koehler, I., Krause, G., & Buchholz, U. (2012) The role of facemasks and hand hygiene in the prevention of influenza transmission in households: results from a cluster randomised trial; Berlin, Germany, 2009-2011. *BMC Infectious Diseases* **12**, 26.

Frank, C., Werber, D., Cramer, J.P., Askar, M., Faber, M., an der Heiden, M., Bernard, H., Fruth, A., Prager, R., Spode, A., Wadl, M., Zoufaly, A., Jordan, S., Kemper, M.J., Follin, P., Müller, L., King, L.A., Rosner, B., Buchholz, U., Stark, K., & Krause, G. (2011) HUS Investigation Team. Epidemic profile of Shiga-toxin-producing *Escherichia coli* O104:H4 outbreak in Germany. *The New England Journal of Medicine* **365**(19), 1771-1780.

Buchholz, U., Bernard, H., Werber, D., Böhmer, M.M., Remschmidt, C., Wilking, H., Deleré, Y., an der Heiden, M., Adlhoch, C., Dreesman, J., Ehlers, J., Ethelberg, S., Faber, M., Frank, C., Fricke, G., Greiner, M., Höhle, M., Ivarsson, S., Jark, U., Kirchner, M., Koch, J., Krause, G., Lubber, P., Rosner, B., Stark, K., & Kühne, M. (2011) German outbreak of *Escherichia coli* O104:H4 associated with sprouts. *The New England Journal of Medicine* **365**(19), 1763-1770.

Schweickert, B., Noll, I., Feig, M., Claus, H., Krause, G., Velasco, E., & Eckmanns, T. (2012) MRSA-surveillance in Germany: data from the Antibiotic Resistance Surveillance System (ARS) and the mandatory surveillance of MRSA in blood. *European Journal of Clinical Microbiology & Infectious Diseases* **31**(8), 1855-1865.

Balabanova, Y., Gilsdorf, A., Buda, S., Burger, R., Eckmanns, T., Gärtner, B., Gross, U., Haas, W., Hamouda, O., Hübner, J., Jänisch, T., Kist, M., Kramer, M.H., Ledig, T., Mielke, M., Pulz, M., Stark, K., Suttrop, N., Ulbrich, U., Wichmann, O., & Krause, G. (2011) Communicable diseases prioritized for surveillance and epidemiological research: results of a standardized prioritization procedure in Germany. *PLoS One* **6**(10), e25691.



Project Leader

Prof. Dr. Emmanuelle Charpentier

Department of Regulation in Infection Biology
(REGI)

emmanuelle.charpentier@helmholtz-hzi.de

Regulation by RNAs and Proteins – Modulators in Bacterial Pathogens

A greater understanding of the fundamental mechanisms of regulation in pathogens is critical to generate new findings for possible translation into novel biotechnological (*e.g.* genome editing tools) and biomedical (*e.g.* anti-infective strategies) applications. The Department “Regulation in Infection Biology” investigates regulation in processes of infection and immunity with a focus on Gram-positive human pathogens. A successful example of potential application of our research in biotechnology and biomedicine is our recent discovery of a novel genome editing tool (dual-RNA programmable DNA cleavage enzyme Cas9) that stems from our analysis of the adaptive immune CRISPR-Cas system in bacterial pathogens.

In our department, we are particularly interested in deciphering how RNAs and proteins succeed to orchestrate and fine-modulate gene expression in bacteria at the transcriptional, post-transcriptional and post-translational level. We study regulatory RNAs and proteins in various biological pathways such as horizontal gene transfer, adaptation to stress, physiology, persistence, virulence, infection and immunity. A favorite pathogen in the laboratory is *Streptococcus pyogenes*, also called Group A streptococcus, that can cause highly aggressive invasive infections such as toxic shock and necrotising diseases. In past years, we have also been investigating the genetics and biology of *Listeria monocytogenes*, *Staphylococcus aureus* and *Streptococcus pneumoniae*.

Streptococcus pyogenes

Fanny Beneyt (Charpentier Department)

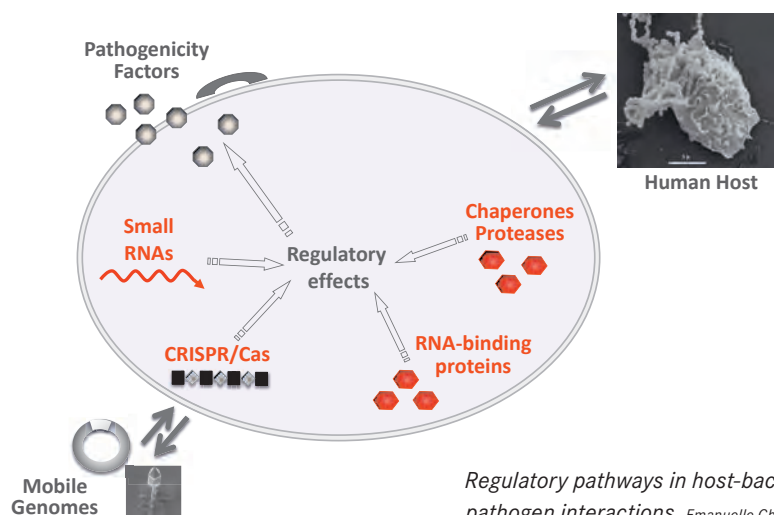
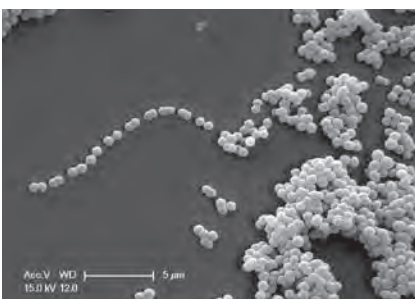

Regulatory pathways in host-bacterial pathogen interactions *Emmanuelle Charpentier*

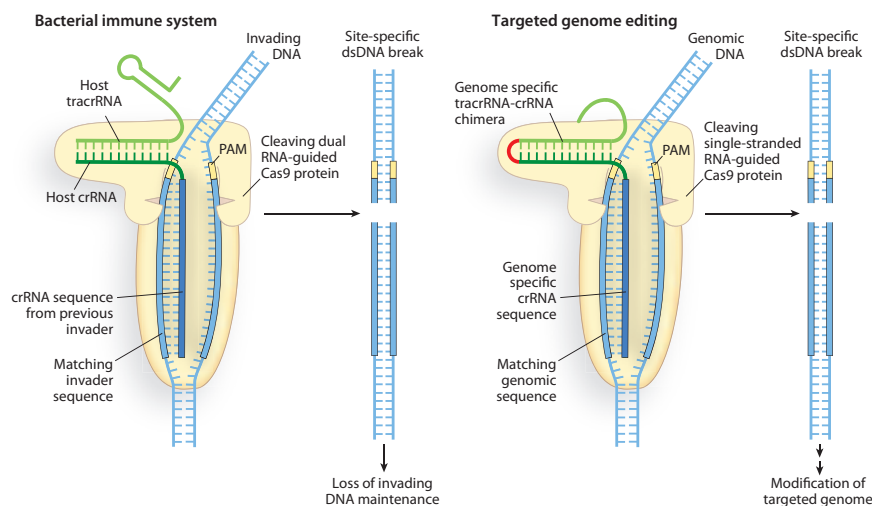

Project Members

Majda Bratovic, Prof. Dr. Emmanuelle Charpentier, Krzysztof Chylinski, Dr. Ines Fonfara, Dr. Sonja Hansen, Muhammad Khanzeb Khan, Anne-Laure Lécrivain, Dr. Ulrike Resch, Anaïs Le Rhun, Dr. Geetanjali Saini, Shi Pey Wong

CRISPR/Cas9 Genome Editing Tool

H. Adam Steinberg (artforscience.com)

Regulation by small RNAs

To protect themselves from the acquisition of detrimental or beneficial genetic material (phages, plasmids), bacteria have evolved an RNA-guided adaptive immunity system, called CRISPR-Cas. We are deciphering the molecular mechanisms involved in the adaptation, expression and interference phases of the immune system and pursuing the detailed analysis of the recently discovered Cas9-tracrRNA:crRNA genome editing device. In addition to the CRISPR-associated RNAs, we are addressing the question how small RNAs and RNA-interacting proteins integrate into the general regulatory network controlling pathogenesis and related mechanisms in *S. pyogenes* at the molecular and cellular level.

Regulation by chaperones/proteases

During infection, bacterial pathogens face a wide variety of adverse and fluctuating conditions within the host and have evolved multiple strategies to mount appropriate responses. Clp (Caseinolytic proteins)/HSP100 (heat-shock proteins) proteins are important components of the bacterial stress response, influencing adaptation, survival or virulence. We have identified substrates of Clps in Gram-positive pathogens and are investigating the mechanisms of substrate targeting and degradation at the molecular and cellular level. We are also interested in the regulation of the clp response by arginine phosphoswitch.

RNA and protein modulators in innate immunity

Initial recognition of pathogens by the innate immune system constitutes the key step in defense against infectious microorganisms. An inappropriate recognition may result in insufficient immune responses, yet an over-activation of the immune system may be equally deleterious. Innate immune cells respond to *S. pyogenes* infection by producing pro-inflammatory cytokines in a manner dependent of the adaptor molecule MyD88. We are interested in investigating RNA- and protein-mediated mechanisms involved in the response of immune cells to *S. pyogenes* infection.

Publications

Charpentier, E. & Doudna, J.A. (2013) Biotechnology: rewriting a genome. *Nature* **495**(7439), 50-51.

Jinek, M., Chylinski, K., Fonfara, I., Hauer, M., Doudna, J.A. & Charpentier, E. (2012) A programmable dual-RNA guided DNA endonuclease in adaptive bacterial immunity. *Science* **337**(6096), 816-821.

Makarova, K.S., Haft, D.H., Barrangou, R., Brouns, S.J., Charpentier, E., Horvath, P., Moineau, S., Mojica, F.J., Wolf, Y.I., Yakunin, A., van der Oost, J. & Koonin, E.V. (2011) Evolution and classification of the CRISPR/Cas systems. *Nature Reviews Microbiology* **9**(6), 467-477.

Deltcheva, E., Chylinski, K., Sharma, C., Gonzales, K., Chao, Y., Pirzada, Z.A., Eckert, M., Vogel, J. & Charpentier, E. (2011) CRISPR RNA maturation by *trans*-encoded small RNA and host factor RNase III. *Nature* **471**(7340), 602-607.

Fuhrmann, J., Schmidt, A., Spiess, S., Lehner, A., Turgay, K., Mechtler, K., Charpentier, E. & Clausen, T. (2009) MscB is a protein arginine kinase that phosphorylates and inhibits the heat-shock regulator CtsR. *Science* **324**(5932), 1323-1327.



Project Leader
Prof. Dr. Susanne Engelmann
 Research Group Microbial Proteomics (MPRO)
 susanne.engelmann@helmholtz-hzi.de

A Proteomics Approach to Understand Host-Pathogen Interactions

Staphylococcus aureus is an emerging pathogen and a leading cause of nosocomial infections worldwide. It can induce a wide variety of infections ranging from mild skin diseases to life-threatening systemic infections such as bacteremia. The pathogenic diversity of *S. aureus* is mediated by a large set of virulence factors produced in different combinations in various isolates. In addition, it becomes more and more evident that specific metabolic traits and their regulatory systems are crucial for fitness and survival of the pathogen during the infection process and thus indirectly impact its virulence potential.

Physiological adaptation of *S. aureus* to different host niches

We established an online resource called *Aureolib* containing 4,692 time dependent protein synthesis profiles for 521 cytosolic proteins of *S. aureus* exposed to nine defined infection-related stimuli. The database can be used as tool for (i) functional predictions of so far uncharacterized proteins based on their expression kinetics, (ii) the integration of stimulons into regulatory networks and (iii) for showing signal transduction systems operating under defined and non-defined growth conditions. During colonization and infection, *S. aureus*

Schematic outline of the workflow for the functional characterization of secreted proteins in *S. aureus* and the expected outcomes. Figure: HZI

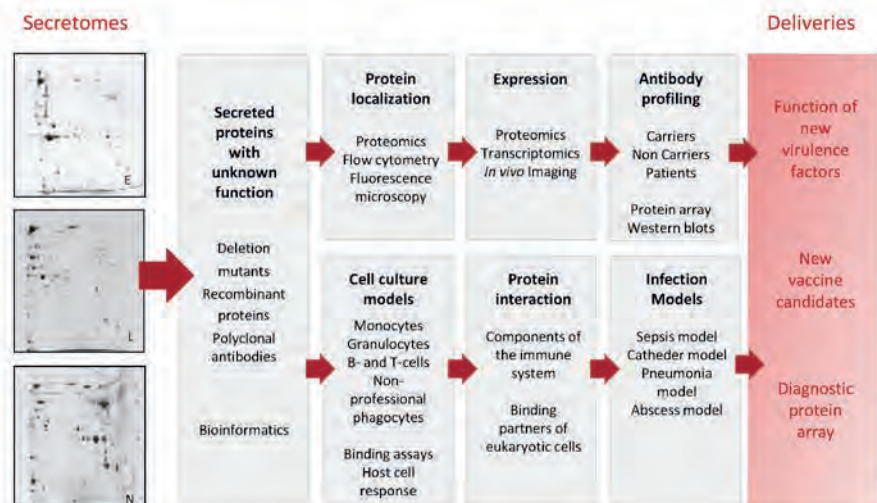

is confronted with a multitude of signals including growth-limiting factors and life-threatening host defense mechanisms. Hence, adaptation of bacterial gene expression in natural habitats is a multi-signal response and it will be an important task to unravel this diverse network. Using *Aureolib* as a tool box, we are currently moving to these more complex, infection-relevant experimental models and we have started to analyze protein expression in *S. aureus* isolated from nasal secretions, milk and macrophages. This data will not only enhance our understanding of *S. aureus* infection biology, but will also decipher the process of nose colonization which is the main risk factor for nosocomial infections.

Regulation and functional characterization of virulence factors in *S. aureus*

Secreted proteins represent a reservoir of virulence factors. By dissecting the exoproteomes of 68 different clinical *S. aureus* isolates, we have demonstrated that, within a single bacterial species, the exoproteome composition can be extremely variable. Despite extensive efforts in functional characterization of virulence factors in *S. aureus*, the overall understanding of mechanisms for the pathogenesis of *S. aureus* infections is limited. This is also reflected by the fact that at least 60% of the secreted proteins are completely uncharacterized so far and were only derived from the genome sequence. In the *S. aureus* secretomes, 77 of these proteins have been identified indicating that they are really expressed. Functional characterization of these particular proteins is a challenging task for our future studies. Mutants of the corresponding genes, recombinant proteins and corresponding polyclonal antibodies are being generated and used for functional characterization. This includes binding to cells of the immune system and non-professional phagocytes, the response of these cells to the proteins, the humoral and cellular immune response, interaction with components of the innate immune system and virulence in animal models. By this way we want to get new insights into immune evasion mechanisms of *S. aureus*. An *S. aureus* protein array is being developed which will be used for detection of antibodies and interaction partners.

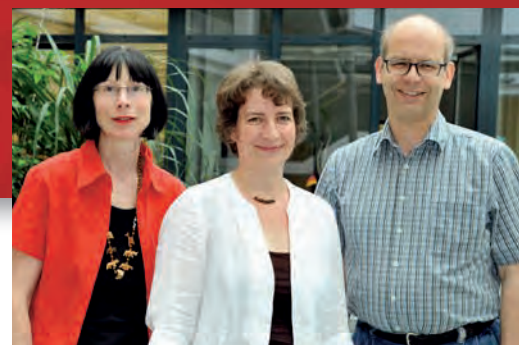

Project Members

Prof. Dr. Susanne Engelmann,
Dr. Martin Kucklick

Publications

Fuchs, S., Zühlke, D., Pané-Farré, J., Kusch, H., Wolf, C., Reiß, S., Binh, L.T.N., Albrecht, D., Riedel, K., Hecker, M., & Engelmann, S. (2013) *Aureolib* – a proteome signature library: Towards an understanding of *Staphylococcus aureus* pathophysiology. *PlosOne*, in press.

Kusch, K., Hanke, K., Holtfreter, S., Schmutde, M., Kohler, C., Erck, C., Wehland, J., Hecker, M., Ohlsen, K., Bröker, B., & Engelmann, S. (2011) The influence of SaeRS and σ^8 on the expression of superantigens in different *Staphylococcus aureus* isolates. *International Journal of Medical Microbiology* **301**, 488-499.

Kolata, J., Bode, L.G.M., Holtfreter, S., Steil, S., Kusch, H., Holtfreter, B., Hecker, M., Engelmann, S., van Belkum, A., Völker, U., & Bröker, B.M. (2011) Distinctive patterns in the human antibody response to *Staphylococcus aureus* bacteremia in carriers and non-carriers. *Proteomics* **11**, 3914-3927.

Ziebandt, A. K., Kusch, K., Degner, M., Jaglitz, S., Sibbald, M.J.J.B., Arends, J.P., Chlebowicz, M.A., Albrecht, D., Pantu ek, R., Doškar, J., Ziebuhr, W., Bröker, B.M., Hecker, M., van Dijk, J.A.M., & Engelmann, S. (2010) Proteomics uncovers extreme heterogeneity in the *Staphylococcus aureus* exoproteome due to genomic plasticity and variant gene regulation. *Proteomics* **10**, 1634-1644.

Becher, D., Hempel, K., Sievers, S., Zühlke, D., Pané-Farré, J., Otto, A., Fuchs, S., Albrecht, S., Bernhardt, J., Engelmann, S., Völker, U., van Dijk, J.M., & Hecker, M. (2009) A proteomic view of an important human pathogen—towards the quantification of the entire *Staphylococcus aureus* proteome. *PLoS One* **4**, e8176.



Project Leader

Prof. Dr. Inari Kursula

Centre for Structural Systems Biology (CSSB)
at DESY

inari.kursula@helmholtz-hzi.de

Actin-based Motility of Pathogenic Parasites

Plasmodium uses an actin-myosin based molecular motor for gliding motility and host cell invasion. Actin polymerization in *Plasmodium* is regulated by a very small set of actin-binding proteins, many of which differ in structure and function from canonical actin regulators. The actin filaments are linked to the inner membrane complex (IMC) and microtubules via myosin A and, via aldolase and so called invasins, which traverse the plasma membrane (PM), to receptors on the host cell surface. Myosin generates a power stroke (red arrow), moving the actin filament backwards, resulting in a net forward movement of the parasite on the host cell surface (green arrows).

Figure: Inari Kursula, adapted from Sattler et al. 2011

Malaria is a devastating worldwide health threat. Annually, over a million people die of malaria and up to 300 million get infected, mostly children and pregnant women. Malaria is also a significant economic burden, trapping the poorest areas in a downward spiral of poverty. Resistance to existing anti-malarial drugs is a growing problem, and there is an urgent need for new drug and vaccine candidates. Malaria is caused by *Plasmodium spp.*, a group of unicellular, eukaryotic, intracellular parasites of the *phylum Apicomplexa*. These parasites use actin for both motility and host cell invasion. Their cytoskeleton differs significantly from that of higher eukaryotes and is, therefore, an attractive target for anti-malarial research. The parasite actin filaments are extremely short and their rapid turnover is regulated by a limited set of actin-binding proteins, which are poorly conserved with their mammalian homologues.

Synchrotron-based structural biology elucidates mechanisms of disease

We aim at an atomic-level understanding of the mechanisms, by which the malaria parasite uses its actin cytoskeleton for motility and host cell invasion, and seek ways to interfere with these processes. We use a combination of modern structural biology, including X-ray crystallography, small-angle scattering of X-rays, and electron microscopy, as well as complementary biophysical and biochemical methods to elucidate structure-function relationships of individual proteins and large regulatory complexes. We are also interested in the development of new synchrotron and free-electron laser applications for visualizing large cytoskeletal complexes at high resolution.

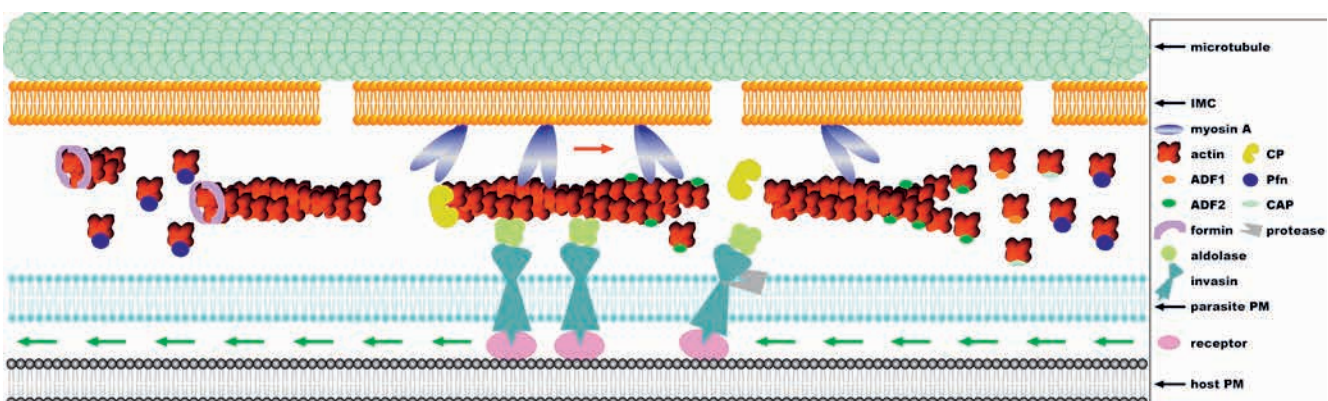

Plasmodium actin-binding proteins have divergent structures and functions

Plasmodium has only 10-15 actin-binding regulatory proteins; a strikingly small number compared to >150 in higher eukaryotes. The most important of these are profilin, formins, actin depolymerization factors (ADF), capping proteins, cyclase-associated protein, and coronin. These proteins have a conserved overall fold, but are poorly conserved at the sequence level and have somewhat divergent functions compared to the corresponding proteins from other eukaryotes.

We have determined the crystal structures of *Plasmodium* profilin and both ADF isoforms. *Plasmodium* profilin, despite structurally deviating significantly from all other profilins, has retained most of the biochemical characteristics of profilins. However, it has a significantly divergent actin-binding surface, rendering it an attractive drug target. Currently, we are characterizing the actin binding of *Plasmodium* profilin in more detail. Of the two *Plasmodium* ADFs, the minor isoform ADF2 has a conserved structure and biochemically resembles conventional ADFs. However, the predominantly expressed ADF1 lacks the filamentous-actin-binding motifs. *Plasmodium* formins efficiently initiate polymerization also of the weakly polymerizing *Plasmodium* actin. However, at least formin 1 works independent of profilin unlike formins from higher eukaryotes.

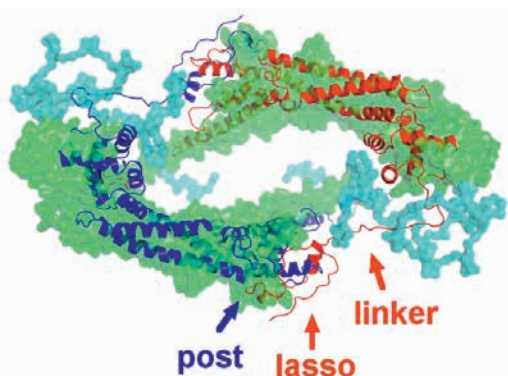

Plasmodium formin 1 nucleates actin polymerization as dimers mediated by the lasso region in its FH2 domain.

Figure: Ignatev et al. 2012, PLoS ONE

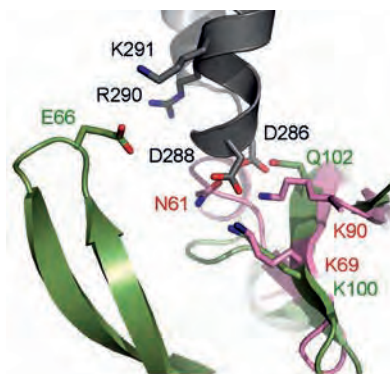

Plasmodium profilin binds actin via a motif unique to apicomplexan profilins. This region of the protein is being investigated for inhibitor design purposes.

Figure: Kursula et al. 2008, Structure

Elucidation of the structure-function relationships in the regulation of actin dynamics will contribute to our understanding of the motility and invasion of the malaria parasite and eventually lead to new drug targets.

At DESY, we have unique possibilities to use the most modern synchrotron and X-ray laser facilities to answer outstanding questions concerning the biology of the most devastating infectious disease.



Project Members

Saligram Prabhakar Bhargav, Moon Chatterjee, Dr. Alexander Ignatev, Dr. Juha Kallio, Esa-Pekka Kumpula, Prof. Dr. Inari Kursula, Dr. Petri Kursula, Gopinath Muruganandam, Juha Vahokoski, Nele Vervaeet

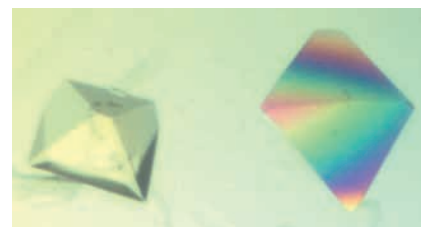

To elucidate the atomic details of the proteins of interest, they are crystallized into microscopic, regular crystals, which diffract X-rays. Figure: Petri Kursula

Publications

Kursula, I., Kursula, P., Ganter, M., Panjekar, S., Matuschewski, K. & Schüler, H. (2008) Structural basis for parasite-specific functions of the divergent profilin of *Plasmodium falciparum*. *Structure* **16**, 1638-1648.

Singh, B.K., Sattler, J.M., Chatterjee, M., Huttu, J., Schüler, H. & Kursula, I. (2011) Crystal structures explain functional differences in the two actin depolymerization factors of the malaria parasite. *Journal of Biological Chemistry* **286**, 28256-28264.

Ignatev, A., Bhargav, S.P., Vahokoski, J., Kursula, P. & Kursula, I. (2012) The lasso segment is required for functional dimerization of the *Plasmodium* formin 1 FH2 domain. *PLoS ONE* **7**, e33586.

Myllykoski, M., Itoh, K., Kangas, S.M., Heape, A.M., Kang, S.U., Lubec, G., Kursula, I. & Kursula, P. (2012) Direct molecular interaction of the myelin enzyme 2',3'-cyclic nucleotide 3'-phosphodiesterase with the calcium sensor calmodulin. *Journal of Neurochemistry* **123**, 515-524.

Ruskamo, S., Chukhlieb, M., Vahokoski, J., Bhargav, S.P., Liang, F., Kursula, I. & Kursula, P. (2012) Juxtanoitin is an intrinsically disordered F-actin binding protein. *Scientific Reports* **2**, 899.



Project Leader

Prof. Dr. Michael Ott

Translational Research Group "Cell and Gene Therapy", Gastroenterology, Hepatology, Endocrinology, MHH / TWINCORE
 ott.michael@mh-hannover.de
 michael.ott@twincore.de

Random and Targeted Genomic Integration of Viral Vectors, Generation of Humanized Liver Tissue in Mice

BALB-ΔRAG/γuPA mice were transplanted with LV-Cd47-GFP transduced hepatocytes. The comparison of selection ratios reveals that the proportion of Cd47-expressing hepatocytes (green nodules) has doubled in the recipient mouse liver. Non-transduced human hepatocytes appear in red colour (immunohistology for human albumin). Overall, our findings strongly indicate a selective advantage for human primary hepatocytes ectopically expressing Cd47. Figure: HZI

The interest in the development and use of humanized mice to investigate human biological systems *in vivo* outside the human body is continuously growing. Humanized mice are either transgenic animals expressing human genes and/or immunodeficient mice engrafted with human cells or tissues. Immunodeficient mice repopulated with human hepatocytes have already proven useful for the study of hepatitis virus life cycles and new antiviral approaches and various immunodeficient strains have emerged from different laboratories over time. We are investigating, how *in vivo* generation of human liver tissue in mice could be improved.

Macrophages play an important role in the rejection of xenogeneic cells and therefore represent a major obstacle to generating chimeric mice with human xenografts. The signal inhibitory regulatory protein α (SIRP α) receptor is a negative regulator of macrophage phagocytic activity and interacts in a species-specific fashion with its ligand CD47. Furthermore, SIRP α polymorphism in laboratory mouse strains significantly affects the extent of human CD47-mediated toleration of human xenotransplants. We could show recently that expression

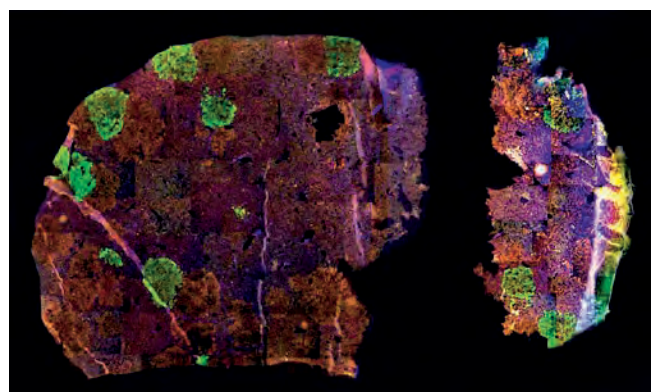
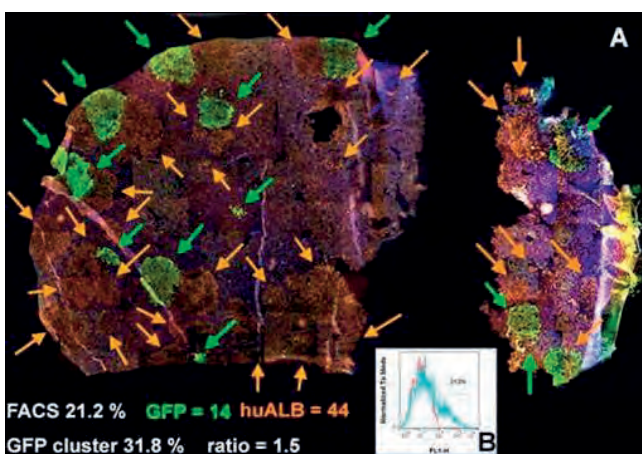

of mouse CD47 in human hepatocytes significantly improves engraftment and repopulation of recipient mouse livers. Another line of research extends to the generation of human liver tissue in mice from renewable stem cell sources such as embryonic stem cells (ESC), induced pluripotent stem cells (iPS) or transprogrammed cells (iHeps).

In a second focus of research we study integration patterns of HIV virus vectors in the hematopoietic system and in the liver. All viruses, which integrate into the genome of a host cell, are capable of activating neighbouring genes and may transactivate oncogenes ("insertional mutagenesis"). Our studies utilizing retroviruses show organ-specific risk profiles for the development of clonal dominance and cancer. Our molecular and bioinformatics tools for the analysis of organ specific integroms will now be extended to other clinically relevant viral pathogens such as hepatitis B virus in clinical samples.

Our ongoing studies aim to increase the availability of humanized mouse models for biomedical research through innovative strategies by improving engraftment/repopulation of recipient mouse livers with human hepatocytes and by substituting primary cells by cell culture grown stem cells. Furthermore, we aim to delineate the role of viral genomic integration and risk of cancer development in the liver.



Project Members

Dr. Asha Balakrishnan, Joel Daon,
Dr. Norman Junge, Kollenda, Prof. Dr.
Michael Ott, Dr. Martin Pacher,
Dr. Amar Sharma, Viola Stückemann,
Qinggong Yuan

Publications

Waern, J.M., Yuan, Q., Rudrich, U., Becker, P.D., Schulze, K., Strick-Marchand, H., Huntington, N.D., Zacher, B.J., Wursthorn, K., Di Santo, J.P., Guzmán, C.A., Manns, M.P., Bock, M., & Ott, M. (2012) Ectopic expression of murine CD47 minimizes macrophage rejection of human hepatocyte xenografts in immunodeficient mice. *Hepatology* **56**, 1479-1488.

Rittelmeyer, I., Rothe, M., Brugman, M., Iken, M., Schambach, A., Manns, M.P., Baum, C., Modlich, U., & Ott, M. (2012) Hepatic lentiviral gene transfer is associated with clonal selection but not with tumor formation in serially transplanted mice. *Hepatology*, doi: 10.1002/hep.26204. [Epub ahead of print]

Haridass, D., Yuan, Q., Becker, P.D., Cantz, T., Iken, M., Rothe, M., Narain, N., Bock, M., Nörder, M., Legrand, N., Wedemeyer, H., Weijer, K., Spits, H., Manns, M.P., Cai, J., Deng, H., Di Santo, J.P., Guzmán, C.A., & Ott, M. (2009) Repopulation efficiencies of adult hepatocytes, fetal liver progenitor cells, and embryonic stem cell-derived hepatic cells in albumin-promoter-enhancer urokinase-type plasminogen activator mice. *American Journal of Pathology* **175**, 1483-1492.





Immune Response and Interventions

The development of efficient strategies to fight infectious diseases continues to represent a major challenge. There are many diseases for which prophylactic vaccines are still missing as well as diseases against which the available vaccines are suboptimal or even ineffective. Thus, one of the main strategic goals is the development of novel immune interventions to prevent or treat infections, and this is to be tackled through the major research aims of this topic:

- dissect transmission, immune modulation and clearance mechanisms of host response to infections
- unravel the immune evasion mechanisms used by pathogens
- develop new immune intervention strategies for prevention or treatment of infectious diseases

Photos from left to right:

Murine models can be used to analyze the immune response after viral infections. RNA was extracted from influenza infected lungs for whole genome transcriptome analysis to understand the complex host response (HZI) | Subcutaneous injection of a mouse with tumor cells at the peritoneal site. The mouse will be eventually infected with light emitting bacteria that migrate to the tumor and produce biofilms. This can be followed using a highly sensitive camera. (HZI) | Investigation of distribution of neutrophilic granulocytes in inflamed tissue by Jadwiga Jablonska-Koch using a laser scanning microscope (HZI)



Topic Speaker

Prof. Dr. Dr. Carlos A. Guzmán

Department of Vaccinology and Applied Microbiology (VAC)

cag@helmholtz-hzi.de

Topic: Immune Response and Interventions

During the last century, major advances in medicine and implementation of vaccination campaigns resulted in the eradication or virtual elimination of major scourges of mankind such as smallpox, polio, measles, mumps, rubella, diphtheria and tetanus. However, the development of efficient strategies to fight infectious diseases continues to represent a major challenge. There are many diseases for which prophylactic vaccines are still missing as well as diseases against which the available vaccines are suboptimal or even ineffective. For example, current formulations of influenza vaccines need to be adapted yearly and confer poor protection in high-risk groups, such as the elderly. Thus, the main strategic aim of this topic is the development of novel immune interventions to prevent or treat infections. Among the major factors hindering this process are: (i) fragmentary knowledge of clearance and immune modulatory mechanisms operating during infection, (ii) incomplete understanding of pathogen-specific immune evasion mechanisms, and (iii) lack of pathogen- and host-tailored immune interventions to prevent or treat specific infections. Therefore, these problems are to be tackled through the major strategic research aims of this topic:

- dissect transmission, immune modulation and clearance mechanisms of host response to infections,
- unravel the immune evasion mechanisms used by pathogens, and
- develop new immune intervention strategies for prevention or treatment of infectious diseases.

Research aim 1: Dissect transmission, immune modulation and clearance mechanisms in infections

The clinical course of an infection depends on the interplay between transmission, susceptibility and immune response. The understanding of these processes represents an essential knowledge for designing any intervention aimed at treating or preventing infection. In this research aim, detailed knowledge will be acquired of the processes that are involved in transmission of infections and stimulation of an immune response during infection. The resulting knowledge will provide the rationale for understanding the immunological effector mechanisms needed to confer efficient protection against selected infections, as well as for identifying novel intervention targets (*e.g.* vaccines, biologicals, small molecules). For this, the work carried out in this research aim involves: (i) unraveling the dynamics of transmission and spread of infections in human populations, (ii) dissecting the role played by innate immune cells and the interferon (IFN) system during infection, (iii) analyzing T cell-mediated effector functions during infection, and (iv) studying development of regulatory T cells (Tregs) and their functional

properties during infection. Expected achievements: (1) identification of host genetic and epigenetic determinants of human susceptibility and resistance to infections; (2) elucidation of the mechanisms that need to be stimulated to clear specific pathogens studied in the programme “Infection Research”; (3) development of strategies to strengthen effector T cells and T cell-dependent B cell responses or to modulate Tregs.

Research aim 2: Unravel the immune evasion mechanisms operative during infection

Pathogens have developed various strategies to subvert the host’s mechanisms to detect and to clear infections. In addition, major physiological and pathological factors affecting immune homeostasis (*e.g.* aging and chronic infections) also lead to a weakened response to infection. The understanding of these mechanisms is a cornerstone for the development of tailored approaches to interfere with pathogen-specific evasion strategies, thereby supporting efficient clearance. These activities represent the core of research aim 2 and they are expected to provide new strategies for the development of innovative immune interventions. Expected achievements: (1) unravel mechanisms of viral and bacterial antagonists of pattern recognition receptors (PRRs) and their downstream signalling pathways; (2) understand molecular mechanisms by which pathogens avoid autophagic recognition and degradation; and (3) understand how chronic infections disrupt the homeostatic balance of the immune system.

Research aim 3: Establish new strategies to prevent and treat infectious diseases

After dissecting the effector mechanisms needed to achieve efficient pathogen clearance upon infection, the most appropriate targets should be identified (*e.g.* antigens). Then, it is crucial to select optimal tools (*e.g.* delivery systems, adjuvants) to stimulate protective responses in a highly predictable manner after vaccination or clearance following a therapeutic immune intervention. It is also essential to tailor the interventions according to the needs of specific population groups (*e.g.* the elderly). Thus, the major goal of this research aim is to establish new tools and strategies to generate prophylactic or therapeutic interventions. To this end, a research plan linked to the other Research Aims and the activities of the other topics was established. More specifically, candidate immune interventions will be optimized according to the knowledge on immune clearance (Research Aim 1), immune escape (Topic 1) and immune evasion (Research Aim 2) operating in the context of specific infections. Antigen identification will result from the discovery programmes established in Topic 1 (*e.g.* hepatitis viruses, influenza, streptococci), as well as from external strategic cooperation partners. To foster the translational process, virtual Cross-Topic Foci Vaccine Strategies will be established that will provide critical expertise, tools and infrastructure. Expected achievements: (1) develop new live vectors and nanoparticles to generate strong, long-lasting and polyfunctional T cell responses; (2) develop new adjuvants, including compounds interfering with the development or action of Tregs; and (3) generate new immune interventions against infections.



Project Leader

Prof. Dr. Dr. Carlos A. GuzmánDepartment of Vaccinology and Applied
Microbiology (VAC)
cag@helmholtz-hzi.de

Vaccine Technologies

Vaccination success depends on the stimulation of well-defined effector mechanisms, which are critical for protection against specific infectious diseases. Our research focuses on the identification of novel adjuvants which are able to stimulate predictable immune responses, particularly those which are amenable for the establishment of mucosal vaccination strategies.

Among our candidate adjuvants are cyclic di-nucleotides (CDNs). In mouse immunization experiments the CDN c-di-AMP is co-administered with model antigens by intra-nasal (i.n.) route promoting humoral as well as cellular immune responses. The analysis of the antibody class composition in serum and mucosal compartments, together with the cytokine profiles, revealed a potent and balanced $T_H1/T_H2/T_H17$ response (Ebensen et al, 2011). We also studied the CDN c-di-GMP as an adjuvant to develop mucosal vaccination alternatives without the risks associated with the access of vaccine components to the central nervous system. The c-di-GMP exhibited potent adjuvant activity when co-administered via sublingual route with an influenza H5N1 virosome-based vaccine. Interestingly, this resulted in a shift from a T_H2 -skewed response to a more balanced T_H1 and T_H2 response, associated with enhanced protection. The stimulated $CD4^+$ T cells also showed a strong cross-reactivity with other influenza strains (Pedersen et al, 2011).

The α GCPEG dependent block of T_H17 polarization is mediated by natural killer T cells (NKT). The x-axis reflects the proliferation state of stimulated $CD4^+$ T cells analyzed by flow cytometry: the gradual loss of the CFSE staining (arrows) reflects the high proliferation of T cells, stimulated by dendritic cells (DC) co-administered with α GCPEG with and without NKT. In addition, the y-axis reflects the expression of the T_H17 marker IL-17. The proliferation of T_H17 cells is high when NKT are absent (red box A), but is blocked in their presence (red box B). Figure: HZI

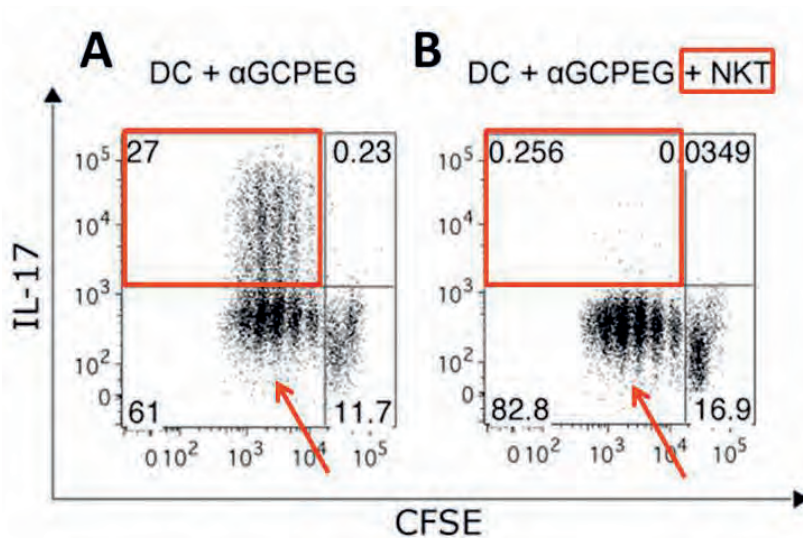

We likewise investigated the specific effects of a pegylated derivative of α -galactosylceramide (α GCPEG) after i.n. immunization of mice. We found that this adjuvant down-regulated the antigen-specific T_H17 response by a mechanism that is mediated by natural killer T cell-secreted IL-4 and IFN- γ (figure). Of particular note, the combination of α GCPEG with other adjuvants can modulate their biological activities toward reduced T_H17 polarization (Zygmunt et al, 2012). This can be exploited as an option during vaccine design, when stimulation of T_H17 responses is not desired or even detrimental.

In the course of our efforts to identify the mechanisms of immune-response regulation during vaccination, we found that IFN- γ -stimulated lymphatic endothelial cells (LECs) show increased MHC class II surface expression and IL-10 secretion which can impair dendritic cell-induced $CD4^+$ T cell proliferation. We also demonstrated the direct interaction of LECs with T cells *in vitro* by clustered surface molecules: CD2 and LFA-1 (CD11a) on the T cells and CD58 and CD54 on the LECs. These findings give an example of immune-response regulation by non-immune cells stimulated by immune signaling molecules (Nörder et al, 2012).

The availability of cost-efficient animal models that allow prediction in humans is a priority. A promising approach is the generation of chimeric mice with human xenografts. To overcome macrophage-mediated rejection of xenogeneic cells, human hepatocytes were transduced with a viral vector coding for a mouse surface molecule, which acts as a “do-not-eat-me” signal. This measure prevented rejection, led to a doubling of the liver repopulation efficiency, and hence, contributes to the establishment of “humanized mice” as a useful tool in preclinical validation (Waern et al, 2012).

The described insights demonstrate our continuous progress in the development of vaccination strategies, especially with regard to adjuvants and refined pre-clinical animal models. This approach will be continued in the future to further the knowledge on successful vaccination strategies and their transfer to the clinic.



Project Members

Alex Cabrera, Dr. Thomas Ebensen, Prof. Dr. Dr. Carlos A. Guzmán, Dr. Miriam Nörder, Dr. Peggy Riese, Dr. Christine Rückert, Dr. Kai Schulze, Ivana Skrnjug, Stephanie Trittel, Dr. Sebastian Weissmann, Dr. Beata Zygmunt

Publications

Ebensen, T., Libanova, R., Schulze, K., Yevsa, T., Morr, M., & Guzmán, C.A. (2011) Bis-(3',5')-cyclic dimeric adenosine monophosphate: strong Th1/Th2/Th17 promoting mucosal adjuvant. *Vaccine* **29**, 5210-5220.

Pedersen, G.K., Ebensen, T., Gjeraker, I.H., Svindland, S., Bredholt, G., Guzmán, C.A.* & Cox, R.J.* (2011) Evaluation of the sublingual route for administration of influenza H5N1 virosomes in combination with the bacterial second messenger c-di-GMP. *PLoS One* **6**, e26973 (* joint senior authors).

Zygmunt, B.M., Weissmann, S.F., & Guzmán, C.A. (2012) NKT cell stimulation with alpha-galactosylceramide results in a block of Th17 differentiation after intranasal immunization in mice. *PLoS One* **7**, e30382.

Nörder, M., Gutierrez, M.G., Zicari, S., Cervi, E., Caruso, A., & Guzmán, C.A. (2012) Lymph node-derived lymphatic endothelial cells express functional co-stimulatory molecules and impair dendritic cell-induced allogenic T cell proliferation. *FASEB Journal* **26**, 2835-2846.

Waern, J.M., Yuan, Q., Rüdich, U., Becker, P.D., Schulze, K., Strick-Marchand, H., Huntington, N.D., Zacher, B.J., Wursthorn, K., Di Santo, J.P., Guzmán, C.A., Manns, M.P., Ott, M., & Bock, M. (2012) Ectopic expression of murine CD47 minimizes macrophage rejection of human hepatocyte xenografts in immunodeficient mice. *Hepatology* **56**, 1479-1488.



Project Leader

Dr. Maximiliano G. Gutierrez

Junior Research Group Phagosome Biology
Department of Vaccinology and Applied
Microbiology (PHAB) | mgg08@helmholtz-hzi.de

Further Project Members

Marc Bronietzki, Achim Gronow, Bahram
Kasmapour, Gang Pei, Dr. Cristiane de Souza
Carvalho, Dr. Cristina Vazquez

Mycobacterial Phagosomes and Immunity

The aim of our research is to give insights into two aspects of the infection with *Mycobacterium tuberculosis*. On one hand, our research focuses on the molecular mechanisms whereby *M. tuberculosis* manipulates the phagosomal environment and avoids killing by phagocytes. We aim to identify bacterial factors that subvert the host cell machinery dedicated to eliminate intracellular pathogens. On the other hand, we try to understand how host phagocytes eliminate mycobacteria. This is important to find possible therapeutic strategies that enhance this natural response. Towards this goal, we study the intracellular transport of mycobacteria in macrophages. We have identified novel promising candidates for being involved in the phagosome-mediated killing process, as well as in the molecular events linking innate and adaptive immune responses.

RAW264.7 macrophages infected with mycobacteria expressing Green Fluorescent protein (GFP, green) and expression of CD36 (labelled in red). Cell nuclei are labelled in blue. Figure: HZI / Vazquez

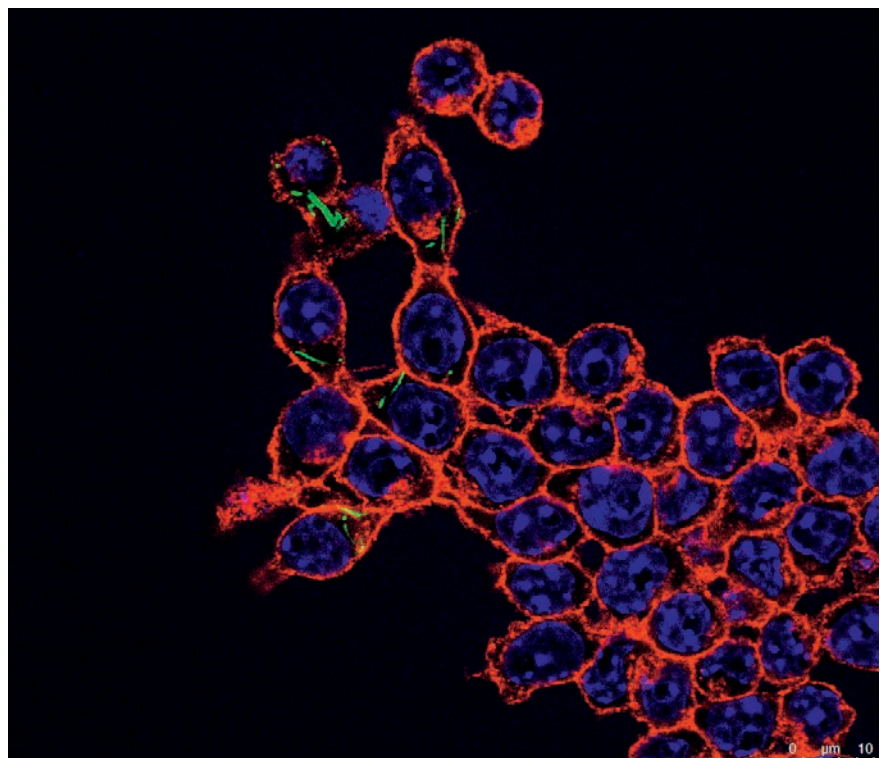

The host perspective

RabGTPases and intracellular trafficking of phagosomes

The phagosome is an organelle that links innate and adaptive immunity. We have identified membrane trafficking regulatory proteins regulated via NF- κ B during the early killing of mycobacteria by macrophages (Gutierrez et al. 2008; Gutierrez et al. 2009; reviewed in Pei et al. 2012). Additionally, we found that nuclear factors are required for mycobacterial killing in epithelial cells as well (de Souza Carvalho et al. 2011). Our aim is to define the functional role of these trafficking proteins in the biology of phagosomes and the innate immune response. We have already identified two novel pathways by which selected cargo is transported to the phagosome during maturation (Wähe et al. 2010, Kasmapour et al. 2012). Moreover, some evidence of transcriptional modulation of intracellular trafficking during tuberculosis has been provided but the molecular mechanisms remains to be elucidated (reviewed in Pei et al. 2012; Pei et al. in preparation). We expect that the knowledge emerging from our studies will identify novel and critical host anti-mycobacterial factors.

The pathogen perspective

Mycobacterial persistence is linked to two of the major obstacles against the eradication of tuberculosis: a large reservoir of people without clinical symptoms and complications in the treatment with antibiotics. However, the fundamental biology of mycobacterial persistence remains a puzzle for biologists. This situation is mainly due to the lack of good models of mycobacterial persistence. In our group, we have established a simple but relevant model of persistence that considers one of the most important aspects of mycobacterial lifestyle: intracellularity. We were able to generate mycobacteria that persist within macrophages for periods of time longer than 2 years. Unexpectedly, the persisting mycobacteria reside in phago-lysosomes and underwent an adaptation process leading to profound changes in lipid metabolism. Our findings illustrate critical events implicated in the establishment of a successful long-lasting persistent infection and represent an invaluable tool for understanding the physiological states of mycobacteria (Vazquez et al. submitted).

Publications

de Souza Carvalho, C., Kasmapour, B., Gronow, A., Rohde, M., Rabinovitch, M., & Gutierrez, M.G. (2011) Internalization, phagolysosomal biogenesis and killing of mycobacteria in enucleated epithelial cells. *Cellular Microbiology* **13**(8), 1234-1249.

Pei, G., Bronietzki, M., & Gutierrez, M.G. (2012) Immune Regulation of Rab proteins expression and intracellular transport. *Journal of Leukocyte Biology* **92**(1), 41-50.

Kasmapour, B., Gronow, A., Bleck, C.K.E., Hong, W., & Gutierrez, M.G. (2012) Size-dependent mechanism of cargo sorting during lysosome-phagosome fusion is controlled by Rab34. *Proceedings of the National Academy of Sciences USA* **109**(50), 20485-20490.

Vazquez, C.L., Kasmapour, B., Pei, G., Gronow, A., Bianco, M.V., Blanco, F.C., Bleck, C.K.E., Bigi, F., Abraham, W.R., & Gutierrez, M.G. (2013) Long-term selection of persistent mycobacteria in phagolysosomes of macrophages, submitted.



Project Leader

Prof. Dr. Klaus Schughart

Department of Infection Genetics (INFG)

kls@helmholtz-hzi.de

Systems Genetics of Infection and Immunity

Our research group is identifying genetic factors, which contribute to the susceptibility or resistance of the host to influenza A infections. For these studies, we are using mouse genetic reference populations consisting of mouse strains with different genetic backgrounds as well as mouse mutants which carry deletions in specific gene loci.

Every year, about 10,000 to 30,000 people die from influenza infections in Germany. The most severe pandemic in recent human history, in 1918, has claimed about 30-50 Million deaths world-wide. The influenza virus is able to change its antigenic properties very rapidly. In addition, the viral genome is segmented and these segments can be exchanged between different virus subtypes. Such re-assorted viruses that arise in animals may then adapt to the human host and cause new pandemics.

It has long been suspected that genetic factors may play an important role for resistance or susceptibility to influenza infections in humans. However, such studies are very difficult to perform in humans and are often blurred by environmental factors, e.g. other serious health conditions, nutrition or medication. Therefore, we have established an experimental model in which we infect mice with different influenza A viruses. In particular, we are studying mouse populations that were derived from laboratory-inbred mouse strains. One of these

BXD mice exhibit variable kinetics of weight loss after infection with influenza A virus. Mice from 53 BXD and the parental strains were infected intra-nasally with 2×10^3 FFU of PR8 virus. Weight loss and survival of infected mice was followed over a period of 13 days. In some strains all infected mice did not lose much weight whereas in other strains all infected mice lost weight rapidly and died soon after infection. For details see Nedelko et al., 2012. Figure: HZI

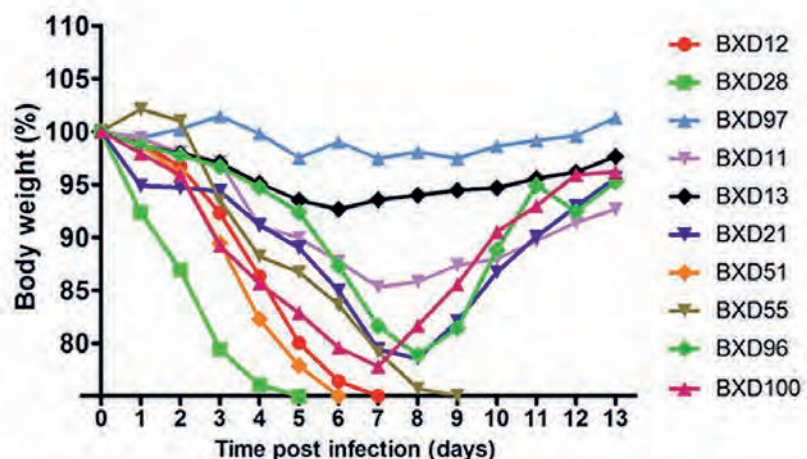

populations, the BXD recombinant inbred strain collection, descends from two parental mouse strains. In the Collaborative Cross population eight parents from five laboratory and three wild-derived strains were used to generate a collection of about 500 strains. In addition, we are analysing the role of individual genes for the host defence to influenza infection by studying mouse lines in which a single gene locus has been mutated by genetic engineering. In our mouse studies, we demonstrated a very strong influence of the genetic background on host susceptibility. One inbred mouse strain, DBA/2J, was highly susceptible to the PR8 H1N1 virus whereas another strain, C57BL/6J, was very resistant. In the susceptible mouse strain the influenza virus replicated much faster and the susceptible strain also exhibited a very strong innate immune response. Our results suggest that the high viral load in the lungs and the hyper-inflammatory response of the immune system are responsible for the fatal outcome of the infection in the susceptible strain. In addition, we showed in mouse mutants that the *Rag2*, *Serpine1* and *Irf7* genes are important for the host to survive an infection with influenza virus. We also performed genome-wide gene expression analyses in the lung over the course of an infection to better understand the host-pathogen interactions at the molecular level and to relate changes in gene expression with cellular responses of the immune system and pathologies in infected lungs.

Our results demonstrate a significant genetic influence in mouse models, which strongly suggests that also in humans many genetic variations may play a role for an efficient host defence. Our research activities are integrated into several national and international networks. We co-ordinate SYSGENET (European network for systems genetics to understand human diseases), and we participate in FluResearchNet (German influenza research network), Infracore (European network to establish mouse phenotyping and archiving infrastructures), and the CTC (world-wide Complex Trait Consortium). In the context of a German-Egyptian Research Project, we will characterize Egyptian H1N1 and H5N1 viral strains.



Project Members

Dr. Mahmoud Bahgat, Silke Bergmann, Leonie Dengler, Dr. Bastian Hatesuer, Hang Thi Thu Hoang, Dr. Heike Kollmus, Sarah Leist, Nora Mehnert, Dr. Tatiana Nedelko, Dr. Carolin Pilzner, Dr. Claudia Pommerenke, Prof. Dr. Klaus Schughart, Dr. Ruth Stricker, Mohamed Tantawy, Dai-Lun Shin, Dr. Esther Wilk

Publications

Blazejewska, P., Kosciński, L., Viegas, N., Anhlan, D., Ludwig, S., & Schughart, K. (2011) Pathogenicity of different PR8 influenza A virus variants in mice is determined by both viral and host factors. *Virology* **412**, 36-45.

Dengler, L., May, M., Wilk, E., Bahgat, M.M., & Schughart, K. (2012) Immunization with live virus vaccine protects highly susceptible DBA/2J mice from lethal influenza A H1N1 infection. *Virology Journal* **9**, 212.

Nedelko, T., Kollmus, H., Klawonn, F., Spijker, S., Lu, L., Hessmann, M., Alberts, R., Williams, R.W., & Schughart, K. (2012) Distinct gene loci control the host response to influenza H1N1 virus infection in a time-dependent manner. *BMC Genomics* **13**, 411.

Pommerenke, C., Wilk, E., Srivastava, B., Schulze, A., Novoselova, N., Geffers, R., & Schughart, K. (2012) Global transcriptome analysis in influenza-infected mouse lungs reveals the kinetics of innate and adaptive host immune responses. *PLoS ONE* **7**, e41169.

Wilk, E., & Schughart, K. (2012) The mouse as model system to study host-pathogen interactions in influenza A infections. *Current Protocols in Mouse Biology* **2**, 177-205.



Project Leader

Prof. Dr. Melanie M. Brinkmann

Junior Research Group Viral Immune Modulation (VIMM)
mbr10@helmholtz-hzi.de

Modulation of Innate Immunity by Herpesviruses

Herpesviruses establish chronic, lifelong infections. To establish persistence, herpesviruses have evolved multiple strategies to counteract the antiviral immune response. A number of different innate immune sensors such as Toll-like receptors (TLR), RIG-I-like receptors, DNA sensors and Nod-like receptors detect viral infection and initiate signalling cascades that result in the production of type I interferons and proinflammatory cytokines. The major focus of our research is to decipher how the human herpesviruses cytomegalovirus (HCMV) and Kaposi's sarcoma herpesvirus (KSHV), as well as their murine counterparts MCMV and MHV68 respectively, modulate the innate immune response to create a beneficial environment for replication and persistence.

Herpesviruses target the innate immune response at multiple levels.

Copyright: Melanie M. Brinkmann

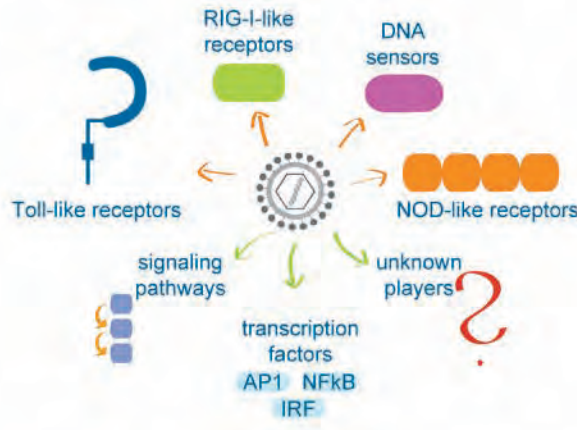

Toll-like receptor signalling is shut down upon MCMV and MHV68 infection in macrophages

Macrophages infected with MCMV or MHV68 do not respond to stimulation with TLR agonists. By using MCMV deletion mutants in a FACS-based screen in macrophages, we identified the M45 protein as a major modulator of the NF- κ B signaling cascade downstream of TLR. To identify KSHV-encoded modulators of TLR-induced NF- κ B signalling, we used a screening approach with ectopically expressed KSHV open reading frames (ORF) in a transient reporter assay. We identified two KSHV ORF with yet unassigned function as potent modulators of NF- κ B signalling downstream of TLR2 and are currently studying their mechanism of action.

MCMV and KSHV block the type I interferon (IFN) response

We identified several MCMV and KSHV ORF that block activation of the IFN α 4 and IFN β promoter in transient reporter assays. By using a proteomics approach we aim to identify the cellular binding partners of the viral modulators of the type I IFN response. Using bacterial artificial chromosome (BAC) genetics, we will create single deletion mutants of MCMV and analyse the mutant viruses lacking the IFN modulator(s) *in vivo*.

TLR9 traffics to endosomal and phagosomal compartments

We created a transgenic mouse model with TLR9 expressed as a green fluorescent protein fusion (TLR9-GFP). This model allows biochemical and cell biological analysis to better understand TLR9 trafficking and processing in primary cells. We found that TLR9 proteolysis, which is essential for conversion of TLR9 into a functional signalling receptor, occurs at a faster rate in B cells than in macrophages. This observation is consistent with an almost exclusive localisation to endolysosomes at the resting state in B cells. Using TLR9-GFP as bait, we identified novel binding partners of TLR9 in macrophages that are currently being studied.



Project Members

Prof. Dr. Melanie M. Brinkmann, Kendra A. Bussey, Baca Chan, Ulrike Lau, Vladimir Gonçalves Magalhães, Sripriya Murthy, Elisa Reimer, Matthias Ottinger, Helene Todt

TLR9-GFP localises to the endolysosomal compartment in primary B cells and macrophages. Copyright: Melanie M. Brinkmann,

Ana M. Avalos

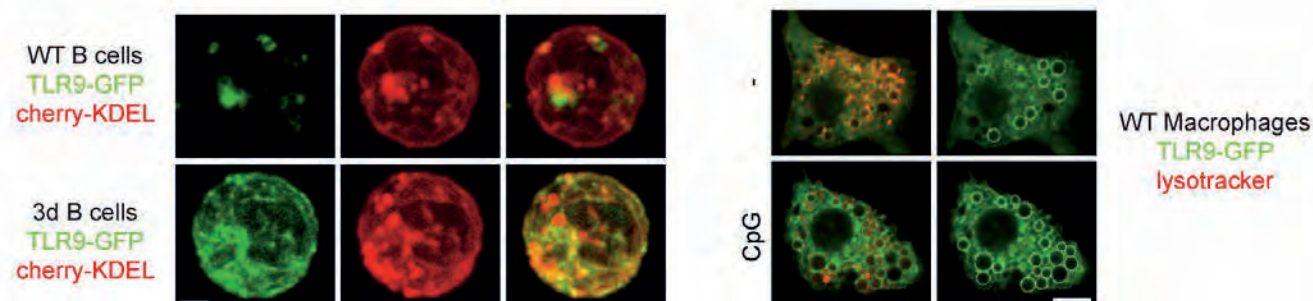

Our aim is to identify novel targets for therapeutic intervention in chronic herpesviral infections. Our studies on the identification of viral immune modulators and their cellular targets will not only contribute to our basic understanding of how herpesviruses interfere with their efficient recognition by the innate immune system, but also help elucidate strategies for viral control.

Publications

Avalos, A.M., Kirak, O., Oelkers, M., Pils, M., Kim, Y.-M., Ottinger, M., Jaenisch, R., Ploegh, H.L., & Brinkmann, M.M. (2013) Cell specific TLR9 trafficking in primary APCs of transgenic TLR9-GFP mice. *Journal of Immunology* **190**(2), 695-702.

Henault, J., Martinez, J., Riggs, J.M., Tian, J., Mehta, P., Clarke, L., Sasai, M., Latz, E., Brinkmann, M.M., Iwasaki, A., Coyle, A.J., Kolbeck, R., Green, D.R., & Sanjuan, M.A. (2012) Noncanonical autophagy is required for type I interferon secretion in response to DNA-Immune complexes. *Immunity* **37**(6), 986-997.

Fliss, P., Jowers, T.P., Brinkmann, M.M., Holstermann, B., Mack, C., Dickinson, P., Hohenberg, H., Ghazal, P., & Brune, W. (2012) Viral mediated redirection of NEMO/IKK γ to autophagosomes curtails the inflammatory cascade. *PLoS Pathogens* **8**(2), e1002517.



Project Leader

Prof. Dr. Dunja Bruder

Research Group Immune Regulation (IREG)
dunja.bruder@helmholtz-hzi.de

Mucosal Immunity and Inflammation

The research group Immune Regulation focusses on dissecting the basic mechanisms underlying the induction and regulation of T cell-mediated inflammatory diseases of the lung, the gut and the pancreas. In recent projects we have investigated the impact of inflammation- and infection-related modulation of host immune responses towards bacterial and viral pathogens on the course of autoimmunity, immunopathology, pathogen persistence and susceptibility to secondary infections. Another aspect we are interested in is the peripheral induction, function and molecular plasticity of regulatory T cells.

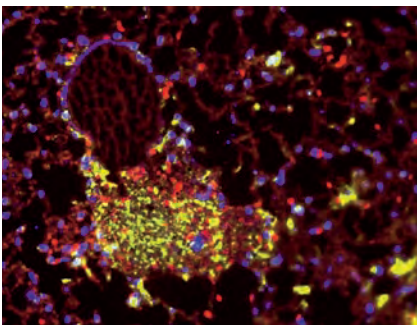

Cell-cell-interactions in the inflamed alveolus. Picture: Jana Bergmann/Christian Hennig, MHH

CD8+ T cell tolerance in autoimmune-mediated lung inflammation

Deciphering the mechanisms controlling autoreactive CD8+ T cell reactivity in the lung we could show that in the steady state, CD8+ T cells reside quiescently next to the self-antigen in the alveoli. Inflammatory stimuli or epithelial injury induces transient activation of self-aggressive CD8+ T cells in the respiratory tract which, however, fail to acquire effector functions and do not precipitate autoimmunity in the lung. We conclude that inadvertent activation of CD8+ T cells in the lung is prevented in the absence of “danger signals”, whereas tissue damage after infection or noninfectious inflammation create an environment that allows the priming of previously ignorant T cells. Our data contributes to a better understanding of the pathogenesis of chronic pulmonary diseases such as COPD and sarcoidosis for which an autoimmune component has been proposed.

IL-22 as a direct target gene for Foxp3

The transcription factor FOXP3 is expressed in regulatory T cells and is considered lineage determinative. Using ChIP-on-chip analysis we identified 90 FOXP3 target genes and demonstrated that IL-22 expression is directly regulated by FOXP3 in human regulatory T cells. The FOXP3-dependent repression of Th17-related IL-22 may be relevant to an understanding of the phenomenon of Treg/Th17 cell plasticity which may have important implication for the development of cell-based therapies of autoimmune diseases with known contribution of Th17 cells, such as multiple sclerosis.

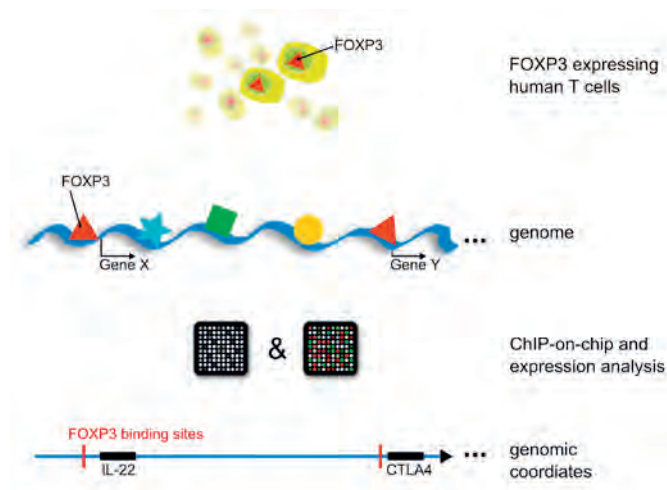

ChIP-on-chip analysis identifies IL-22 as novel target gene of FOXP3 in human regulatory T cells. Graphic: HZI/Andreas Jeron

TLR7 and influenza A – *Streptococcus pneumoniae* superinfection

Influenza A virus infection modulates host immunity to secondary bacterial infections. This increased risk for bacterial superinfections substantially contributes to the mortality caused by influenza A virus epidemics. We could show that TLR7-deficient mice induced a potent antiviral response and showed a fatal outcome in secondary pneumococcal infection during acute influenza similar to wild-type (WT) hosts, despite significantly delayed disease progression. Also, when bacterial superinfection occurred after virus clearance, WT and TLR7-deficient hosts showed similar mortality. Even though we found the phagocytic activity of alveolar macrophages from IAV-pre-infected hosts to be enhanced in TLR7ko over WT mice. Thus, we show that a virus-sensing pattern-recognition receptor TLR7 modulates the progression of secondary pneumococcal infection following IAV and may, therefore, represent an interesting target for therapeutic interventions.

Understanding the basic mechanisms that contribute to maintenance of peripheral T cell tolerance to self-antigen, the specific conditions that support breakdown of tolerance and therefore promote development of autoimmunity as well as the impact of infections in modulating host responses toward self-tissue and secondary infections will help to develop improved treatments of autoimmune and infectious disorders.



Project Members

Andrea Autengruber, Julia Boehme, Prof. Dr. Dunja Bruder, Dr. Marcus Gereke, Dr. Andreas Jeron, Gerald Parzmair, Kathleen Rogge, Dr. Priya Sakthivel, Nihkarika Sharma, Dr. Sabine Stegemann-Koniszewski

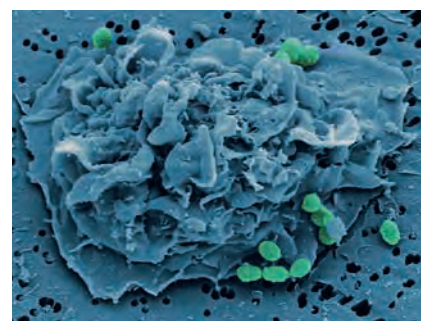

Macrophage ingesting bacteria (shown in green). Photo: HZI/Manfred Rohde

Publications

Jeron, A., Hansen, W., Ewert, F., Buer, J., Geffers,* R. & Bruder,* D. (2012) ChIP-on-chip analysis identifies IL-22 as direct target gene of ectopically expressed FOXP3 transcription factor in human T cells. *BMC Genomics* **13**, 705. *equal contribution.

Stegemann-Koniszewski, S., Gereke, M., Orrskog, S., Lienenklaus, S., Pasche, B., Bader, S.R., Gruber, A.D., Akira, A., Weiss, S., Henriques-Normark, B., Bruder,* D., & Gunzer,* M. (2013) TLR7 contributes to the rapid progression but not to the overall fatal outcome of secondary pneumococcal disease following influenza A virus infection. *Journal of Innate Immunity* **5**(1), 84-96. Epub 2012 Nov 15. *equal contribution.

Gereke, M., Autengruber, A., Gröbe, L., Jeron, A., Bruder, D., & Stegemann-Koniszewski, S. (2012) Flow cytometric isolation of primary murine type II alveolar epithelial cells for functional and molecular studies. *Journal of Visualized Experiments*, in press.

Tosiek, M.J., Bader, S., Gruber, A.D., Buer, J., Gereke,* M., & Bruder,* D. (2012) CD8+ T cells responding to alveolar antigen lack CD25 expression and fail to precipitate autoimmunity. *American Journal of Respiratory Cell and Molecular Biology* **47**(6), 869-878. Epub 2012 Sep 13. *equal contribution

Sakthivel, P., Gereke, M., & Bruder, D. (2012) Therapeutic intervention in cancer and chronic viral infections: Antibody mediated manipulation of PD-1/PD-L1 interaction. *Reviews on Recent Clinical Trials* **7**(1), 10-23.



Project Leader

Prof. Dr. Jochen Hühn

Department of Experimental Immunology
(EXIM)

jochen.huehn@helmholtz-hzi.de

Development and Functional Properties of $Foxp3^+$ Regulatory T Cells

Regulatory T cells (Tregs) play a key role for the maintenance of self-tolerance and can modulate type and strength of immune responses directed against invading pathogens. Therefore, Tregs are considered as promising therapeutic targets. On the molecular level, Tregs are characterized by the expression of the transcription factor *Foxp3*, which is instrumental for the Tregs' unique phenotype. Epigenetic modifications within the *Foxp3* gene are required to stabilize *Foxp3* expression and to ensure long-term lineage identity. The majority of $Foxp3^+$ Tregs is already generated during the development of T cells within the thymus. However, peripheral conversion of conventional T cells into $Foxp3^+$ Tregs takes place preferentially within gut-draining lymph nodes, and it has been suggested that this conversion is critical to tolerize non-pathogenic foreign antigens, including commensal microbiota and food.

Fig. 1. (left) $Foxp3^+$ Tregs within the thymus. T cells and $Foxp3^+$ Tregs were stained with fluorescently labelled antibodies in red and green, respectively. Picture: Dr. Eberl, Pasteur Institute, Paris, France.

*Fig. 2. (right) $Foxp3^+$ Treg interacting with *Yersinia pseudotuberculosis*.*

Picture: Dr. Manfred Rohde, HZI, Braunschweig.

To be able to selectively modulate either development or suppressive activity of $Foxp3^+$ Tregs, a comprehensive understanding of their biological properties is of utmost importance. Thus, the major objective of this project is to thoroughly characterize both cellular players and molecular mediators controlling development and function of $Foxp3^+$ Tregs and to identify molecular targets allowing their selective modulation.

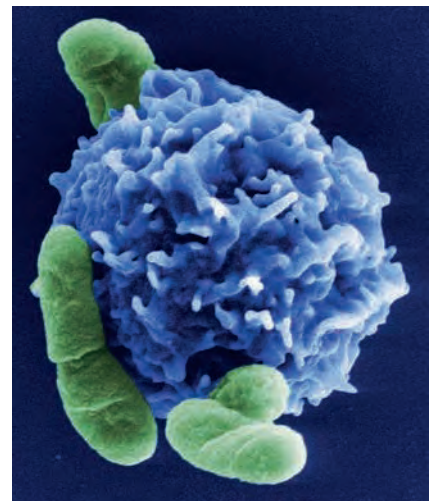
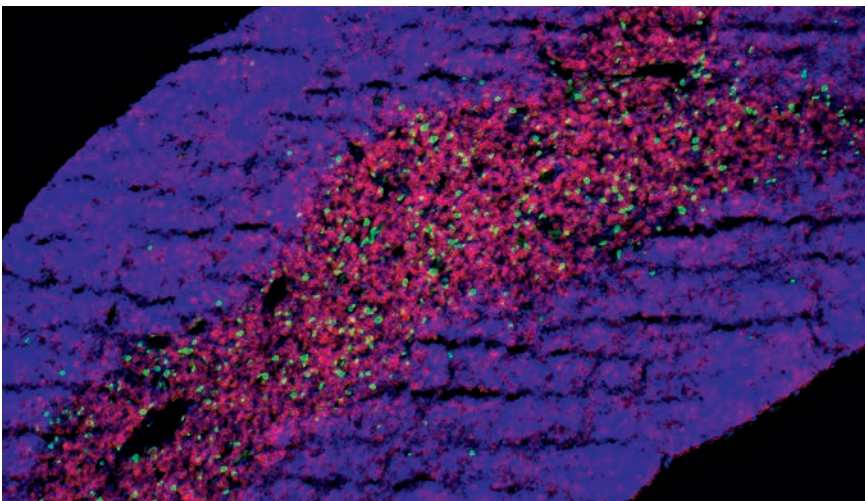

Results

To delineate those mechanisms leading to the epigenetic fixation of the Treg lineage, we aimed to identify the time point during Treg development at which the *Foxp3* gene becomes epigenetically modified. We could demonstrate that these modifications are introduced already during early stages of thymic Treg development and involve active demethylation mechanisms (Toker et al., 2013). Once being introduced, these and additional epigenetic modifications at other Treg-specific genes operate as a kind of molecular switch, leading to the fixation of the Treg lineage (Miyao et al., 2012; Ohkura et al., 2012).

The preferential *de novo* generation of Foxp3⁺ Tregs within gut-draining lymph nodes relies on unique properties of the lymph nodes' stromal cells, as we could demonstrate with the help of lymph node transplantations. Interestingly, microenvironmental factors, such as commensal microflora or vitamin A, positively influence the Treg-inducing properties of gut-draining lymph nodes by imprinting the tolerogenic phenotype within the stromal cells. In contrast, gastrointestinal infections were found to severely impair the Treg-inducing capacity of gut-draining lymph nodes.

Finally, proteomic and phosphoproteomic profiling of Foxp3⁺ Tregs led to the identification of putative molecular targets, which show unique expression or phosphorylation patterns in Tregs and which are probably of central importance for the Tregs' functional properties.

- The thymic microenvironment contributes to the epigenetic fixation of the Treg lineage. We will use this knowledge to generate stable Foxp3⁺ Tregs for the therapeutic treatment of patients suffering from immune-mediated diseases.
- Microenvironmental factors modulate the Treg-inducing capacity of gut-draining lymph nodes. We aim to better understand the molecular mechanisms behind this imprinting and will study the long-lasting effects of gastrointestinal infections.
- The unique protein expression and phosphorylation profiles of Foxp3⁺ Tregs will be used to develop Treg-modulating drugs that either selectively eliminate Tregs or transiently inhibit their suppressive capacity during vaccinations against tumors and chronic infections.



Project Members

Pedro Almeida, Carla Farah, Dr. Diana Fleißner, Dr. Stefan Flöß, Garima Garg, Dr. Lothar Gröbe, Dr. Yi-Ju Huang, Prof. Dr. Jochen Hühn, Devesha Kulkarni, Jörn Pezoldt, Dr. Lisa Schreiber, Dr. René Teich, Aras Toker, Bi-Huei Yang

Publications

Toker, A., Engelbert, D., Garg, G., Polansky, J.K., Floess, S., Miyao, T., Baron, U., Düber, S., Geffers, R., Giehr, P., Schallenberg, S., Kretschmer, K., Olek, S., Walter, J., Weiss, S., Hori, S., Hamann, A., & Huehn, J. (2013) Active demethylation of the Foxp3 locus leads to the generation of stable regulatory T cells within the thymus. *Journal of Immunology* **90**, 3180-3188.

Ohkura, N., Hamaguchi, M., Morikawa, H., Sugimura, K., Tanaka, A., Ito, Y., Osaki, M., Tanaka, Y., Yamashita, R., Nakano, N., Huehn, J., Fehling, H.J., Sparwasser, T., Nakai, K., & Sakaguchi, S. (2012) T cell receptor stimulation-induced epigenetic changes and foxp3 expression are independent and complementary events required for treg cell development. *Immunity* **37**, 785-799.

Miyao, T., Floess, S., Setoguchi, R., Luche, H., Fehling, H.J., Waldmann, H., Huehn, J., & Hori, S. (2012) Plasticity of Foxp3⁺ T cells reflects promiscuous Foxp3 expression in conventional T cells but not reprogramming of regulatory T cells. *Immunity* **36**, 262-275.



Project Leader

Prof. Dr. Ingo Schmitz

Research Group Systems-Oriented
Immunology and Inflammation Research
(SIME)
isc09@helmholtz-hzi.de

Cell Death Mechanisms in Immunity

An adaptive immune response against invading pathogens is orchestrated by T lymphocytes and their activation is enabled by two fundamental processes – apoptosis and autophagy. The latter is a lysosomal degradation pathway that generates metabolites for macromolecular synthesis and energy production during T cell activation. Moreover, autophagy can act as an “intracellular immune system” by degrading intracellular pathogens. Apoptosis is a form of programmed cell death that is important to down-regulate immune responses, which is required to prevent autoimmunity. Next to apoptosis, regulatory T (Treg) cells are important negative regulators of T cell responses. All three mechanisms – autophagy, apoptosis and Treg cells – can be targeted by pathogens. Our research tries to uncover molecular mechanisms that can be exploited for therapeutic interventions.

Transcriptional regulation of the Foxp3 gene. The forkhead (Foxp3) gene, which is located on the X chromosome, is evolutionary conserved. Next to the coding exons and the promoter, three additional conserved non-coding sequences (CNS) were identified that regulate Foxp3 expression. CNS1 is sensitive to Smad transcription factors, activated by transforming growth factor beta (TGFβ). CNS2 (Treg-specific demethylation region (TSDR)) is regulated by epigenetic modifications. CNS3 is a pioneer element involved in opening of the gene locus. All regulatory sequences contain binding sites for T cell receptor (TCR)-activated transcription factors such as NFAT and NFκB. The novel Foxp3 regulator, IκB_{NS}, is also induced by the TCR and binds via NFκB proteins to the Foxp3 locus. HZI

Apoptotic signal transduction

Death receptors such as CD95 (APO-1/Fas) play a crucial role in a number of immunological processes such as T cell-dependent immune responses. Our research concentrates on the FLICE-inhibitory proteins (FLIP) that are important regulators of CD95 signaling. FLIP proteins have been identified in mammalian cells (cellular FLIP = c-FLIP) as well as in γ-herpes viruses (v-FLIP). We showed

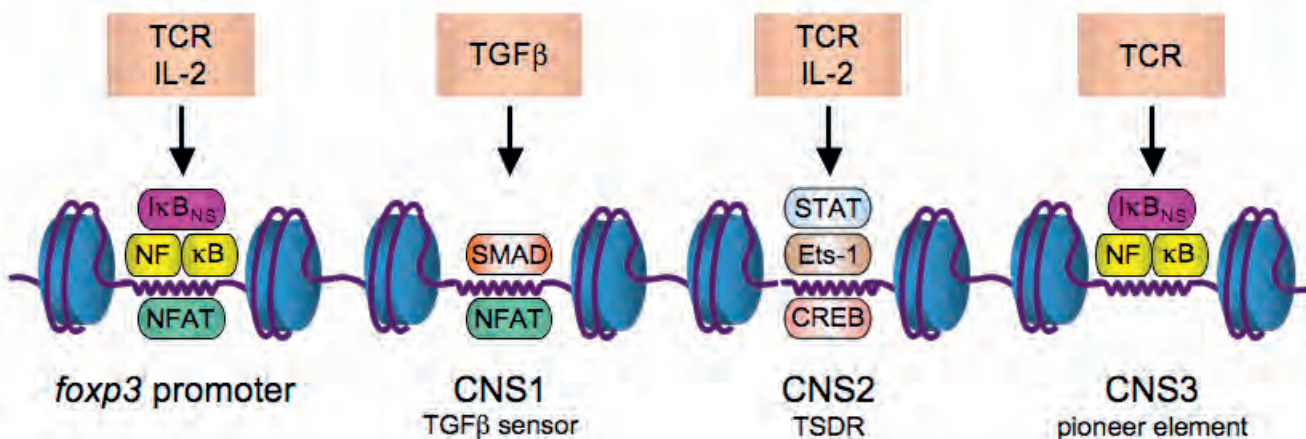

that the long and short splice variants of c-FLIP are of different importance for apoptosis resistance in different cells. Furthermore, we generated a novel transgenic mouse model and demonstrated that constitutive expression of the splice variant c-FLIP_R converses resistance to CD8⁺ cytotoxic T cells and thus, allows for a better immune response against the intracellular bacterium *Listeria monocytogenes*.

Autophagy

Autophagy is a lysosomal degradation pathway that is important for cellular homeostasis, mammalian development and immunity. On the one hand, autophagy is able to eliminate intracellular pathogens. On the other hand, however, some pathogens use the autophagic pathway to escape immune recognition. Though the process of autophagy has been elucidated on the molecular level in recent years, little is known about signalling mechanisms regulating the effector functions of these molecules. We have recently uncovered a novel signalling pathway involving Gadd45 β and the stress kinase p38 that inhibits Atg5 activity, which is an essential component of the autophagic pathway. We will address the role of autophagy regulation for the intracellular survival of *Staphylococcus aureus* in mammalian cells.

Regulatory T cells

The activity of the immune system is regulated by the balance of immunosuppressive regulatory T (Treg) cells and activated effector cells. Thus, Treg cells set a threshold for T cell activation and are involved in the down-regulation of an immune response. The transcription factor Foxp3 is essential for the regulation of Treg cell development and maintenance of their suppressive function. Recent studies demonstrated that activation of the NF κ B pathway is required for Foxp3 induction. Our research group could show that Foxp3 induction critically depends on the atypical NF κ B inhibitor I κ B_{NS} since it acts a transcriptional co-factor for NF κ B on the Foxp3 gene. As a consequence I κ B_{NS}-deficient mice display a strong reduction of mature regulatory T cells. We also found using a transfer colitis model an exacerbated disease course caused by the deficiency of I κ B_{NS}.



Project Members

Michaela Annemann, Svenja Bruns, Frida Ewald, Ralf Höcker, Tobias Lübke, Carlos Plaza, Dr. Yvonne Rauter, Prof. Dr. Ingo Schmitz, Dr. Marc Schuster, Tanja Telieps, Alisha Walker

Publications

Ewald, F., Ueffing, N., Brockmann, L., Hader, C., Telieps, T., Schuster, M., Schulz, W.A., & Schmitz, I. (2011) The role of c-FLIP splice variants in urothelial tumours. *Cell Death and Disease*, **e245**, doi: 10.1038/cddis.2011.131.

Guerrero, A.D., Schmitz, I., Chen, M., & Wang, J. (2012) Promotion of Caspase Activation by Caspase-9-mediated Feedback Amplification of Mitochondrial Damage. *Journal of Clinical & Cellular Immunology*, **3**, 126, doi: 10.4172/2155-9899.1000126.

Schuster, M., Glauben, R., Plaza-Sirvent, C., Schreiber, L., Annemann, M., Floess, S., Kühl, A.A., Clayton, L.K., Sparwasser, T., Schulze-Osthoff, K., Hühn, J., Siegmund, B., Pfeffer, K., & Schmitz, I. (2012) I κ BNS Protein Mediates Regulatory T Cell Development via Induction of the Foxp3 Transcription Factor. *Immunity* **37**(6), 998-1008, doi: 10.1016/j.immuni.2012.08.023.

Keil, E., Höcker, R., Schuster, M., Essmann, F., Ueffing, N., Hoffman, B., Liebermann, D.A., Pfeffer, K., Schulze-Osthoff, K., & Schmitz, I. (2013) Phosphorylation of Atg5 by the Gadd45-MEK4-p38 pathway inhibits autophagy. *Cell Death & Differentiation* **20**(2), 321-332, doi: 10.1038/cdd.2012.129.

Telieps, T., Ewald, F., Gereke, M., Annemann, M., Rauter, Y., Schuster, M., Ueffing, N., von Smolinski, D., Gruber, A.D., Bruder, D., & Schmitz, I. (2013) Cellular-FLIP, Raji isoform (c-FLIP(R)) modulates cell death induction upon T-cell activation and infection. *European Journal of Immunology*, doi: 10.1002/eji.201242819. [Epub ahead of print]



Project Leader

Dr. Siegfried Weiss

Research Group Molecular Immunology (MOLI)
siw@helmholtz-hzi.de

Immune Effectors: Molecules, Cells and Mechanisms

Upon pathogen challenge, the so-called innate immune system, to which specialized myeloid cells belong, reacts first. This normally results in an inflammatory reaction that enhances first line reactions and alerts the specific or adaptive immune system. The effector mechanisms elicited then, clear the pathogenic challenge unless the pathogen or pathogenic conditions subvert the reactions of the immune system.

Induction of type I interferon (IFN) is one of the first defense reactions. Although originally discovered as an anti-viral system, it is clear now that it plays also an important role during many other infectious processes. We recently have introduced a novel reporter/conditional knock-out mouse to determine cells that are responsible for the production of IFN- β , the most important type I IFN. Using such mice, we noticed that tumours grew faster in the absence of a functional IFN system. This was due to an increased influx of IFN regulated neutrophilic granulocytes. Besides an increase in pro-angiogenic factors, such neutrophils also produced more neutrophil-attracting chemokines (auto-attraction) and survived longer in the absence of IFN. Thus, IFN is one of the natural tumour surveillance systems that act partially via the regulation of neutrophil differentiation. These findings might eventually result in improved IFN cancer therapies.

Histology of the mesentery of a mouse chronically infected with MAP. Left panel: Zeel-Nielson staining. The red accumulations represent clusters of MAP's. Right panel: Hematoxilin-Eosin staining. The accumulation of stained cells represents a granuloma consisting of T cells and most likely neutrophilic granulocytes. HZI

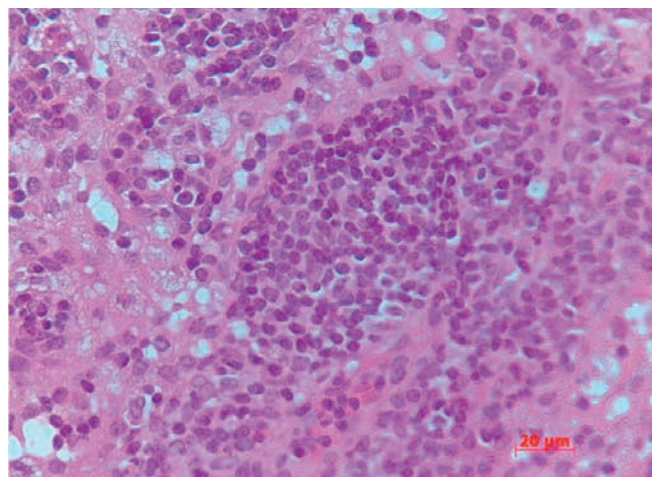
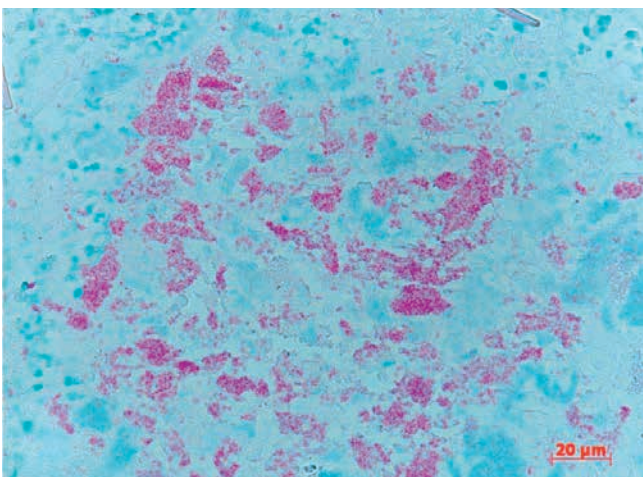

It is also one of our goals to use bacteria for therapy against solid tumours, in our case *Salmonella enterica* serovar Typhimurium and *Escherichia coli*. When applied intravenously to mice bearing a solid tumour, such bacteria selectively colonise the neoplastic tissue. Often this results in growth retardation of the tumour or even clearance. As a mechanism we could identify the induction of a strong T cell response by CD8 as well as by CD4 T cells. Apparently, when the bacteria invade the tumour and induce a large necrotic region tumour antigen is liberated. Then, together with the adjuvant effect of the bacteria, the therapeutic immune response is elicited. We want to elaborate on this finding in the future by strengthening the immune reaction in tumour systems which do not readily respond to the bacterial therapy. In addition, we want to use such bacteria as carriers for therapeutic molecules. For a tumour-specific therapy we have identified bacterial promoters that should restrict expression of toxic molecules exclusively to the neoplasia. A very interesting side aspect of this work is that many bacteria like *Pseudomonas aeruginosa* form biofilms in the neoplastic tissue. This allows us now to test parameters that are required for the bacteria to form biofilms but also to use it as an *in vivo* test system for anti-biofilm drugs. We have successfully started such experiments.

We developed an additional animal model for *Mycobacterium avium* subspecies *paratuberculosis* (MAP) infection. These bacteria are known to cause Johne's disease in ruminants and are suspected to initiate Crohn's disease in humans although this is still very controversial. To obtain more insight, we have intraperitoneally infected mice with MAP. Interestingly, when rechallenged by the same bacteria, mice developed a transient diarrhea and show strong indications of inflammatory bowel disease. As location where the bacteria chronically reside we could define the mesentery. These experiments should allow formulating testable hypothesis which should lead to novel diagnostic work with human patients to clarify whether MAP is the causative agent of Crohn's disease.



Project Members

Lisa Andzinski, Imke Bargaen, Sara Bartels, Anne-Margarete Brennecke, Katja Crull, Igor Deyneko, Dr. Sandra Düber, Michael Frahm, Aida Iljazovic, Dr. Jadwiga Jablonska-Koch, Nadine Kasnitz, Dino Kocijancic, Uliana Komor, Dr. Stefan Lienenklaus, Vinay Pawar, Dr. Bishnudeo Roy, Evgenyia Solodova, Christian Stern, Abdulhadi Suwandi, Dr. Siegfried Weiss, Kathrin Wolf, Ching-Fang Wu

Selected Publications

Zietara, N., Lyszkiewicz, M., Puchalka, J., Pei, G., Gutierrez, M.G., Lienenklaus, S., Hobeika, E., Reth, M., Martins Dos Santos, V.A.P., Krueger, A., & Weiss, S. (2013) Immunoglobulins drive terminal maturation of splenic dendritic cells. *Proceedings of the National Academy of Sciences*, Epub.

Bielecki*, P., Komor*, U., Bielecka, A., Müsken, M., Puchalka, J., Pletz, M.W., Ballmann, M., Martins dos Santos, V.A.P., Weiss#, S., & Häussler#, S. (2013) Ex vivo transcriptional profiling reveals a common set of genes important for the adaptation of *Pseudomonas aeruginosa* to chronically infected host sites. *Environmental Microbiology* **15**, 570-587. *joined first authorship; #joined last authorship.

Komor, U., Bielecki, P., Loessner, H., Rohde, M., Wolf, K., Westphal, K., Weiss*, S., & Häussler*, S. (2012) Biofilm formation by *Pseudomonas aeruginosa* in solid murine tumors – a novel model system. *Microbes and Infection* **14**, 951-958. *joined last authorship.

Leschner, S., Deyneko, I.V., Lienenklaus, S., Wolf, K., Bloecker, H., Bumann, D., Loessner, H., & Weiss, S. (2011) Identification of tumor specific *Salmonella* Typhimurium promoters and their regulatory logic. *Nucleic Acids Research* **40**, 2984-2994.

Crull, K., Rohde, M., Westphal, K., Loessner, H., Wolf, K., Felipe-López, A., Hensel, M., & Weiss, S. (2011) Biofilm formation by *Salmonella enterica* serovar Typhimurium colonizing solid tumors. *Cellular Microbiology* **13**, 1223-1233.



Project Leader

Dr. Andrea Kröger

Research Group Innate Immunity and Infection (IMMI)

akg@helmholtz-hzi.de

Interferons in Viral Defense and Immunity

During infection, a pathogen invades into the host. The host recognizes the pathogen and starts a defense programme to evade from the infection. The type I IFN System is the first line of defense against viral infections. Cells respond rapidly to infection with the induction of IFNs to protect themselves and to minimize damage to the organism. In addition, IFNs contribute to the coordination of a long lasting immune response and the elimination of infected cells. The aim of the project is the understanding of the regulation of the IFN response in single cells, cell populations and the whole organisms to open new opportunities for the prevention of infections and diseases.

The IFN network

A well-orchestrated regulation of the IFN response is required for a complete elimination of the infections and the induction of protective immune responses. By live-cell imaging, we show that key steps of virus-induced signal transduction, IFN- β expression, and induction of IFN-stimulated genes (ISGs) are stochastic events in individual cells. Mathematical modelling and experimental validation show that reliable antiviral protection in the face of multi-layered cellular stochasticity is achieved by paracrine response amplification. Achieving coherent responses through intercellular communication is likely to be a more widely used strategy by mammalian cells to cope with pervasive stochasticity in signalling and gene expression.

Fail-safe pathway for antiviral activity

Hepatitis C virus (HCV) is a major cause of chronic liver disease in humans. We found that the Interferon Regulatory Factor (IRF)-3 and the response to type I IFNs are crucial in limiting HCV replication. Like many other viruses, HCV developed strategies to inhibit the induction and function of type I IFN. We found that in addition to type I IFN-mediated antiviral responses, IRF-1 and IRF-5-dependent antiviral mechanisms restrict HCV replication. These IFN-independent mechanisms could be important to inhibit viral replication when the virus escapes antiviral function of the IFN system.

IRF-1 induces innate and adaptive immune responses

Circulating immune cells control the body to eliminate infected or transformed cells, a process known as immune surveillance. Using a lung metastasis model we could show that IRF-1 is important for IFN mediated immune surveillance in metastasis. IRF-1 leads to an attraction and activation of natural killer cells and thereby to the elimination of tumour cells. This mechanism is independent of inhibitory receptors and cytotoxic granules but dependent on DNAM-1. Detailed analysis of the microenvironment and the signalling cascades of the infiltrating immune cells will elucidate the mechanism of immune response induction in the future.

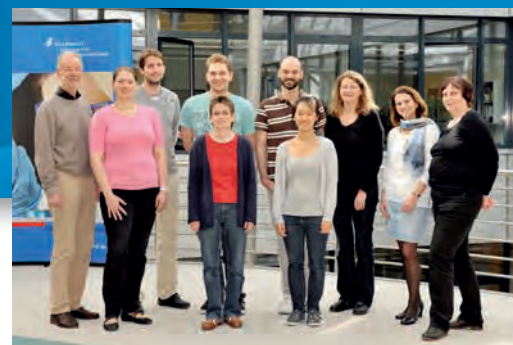

Project Members

Katja Finsterbusch, Prof. Dr. Hansjörg Hauser, Lucas Kemper, Dr. Mario Köster, Dr. Andrea Kröger, Dr. Ramya Nandakumar, Sharmila Nair, Johannes Schwerk, Danim Shin, Markus Wolfsmüller

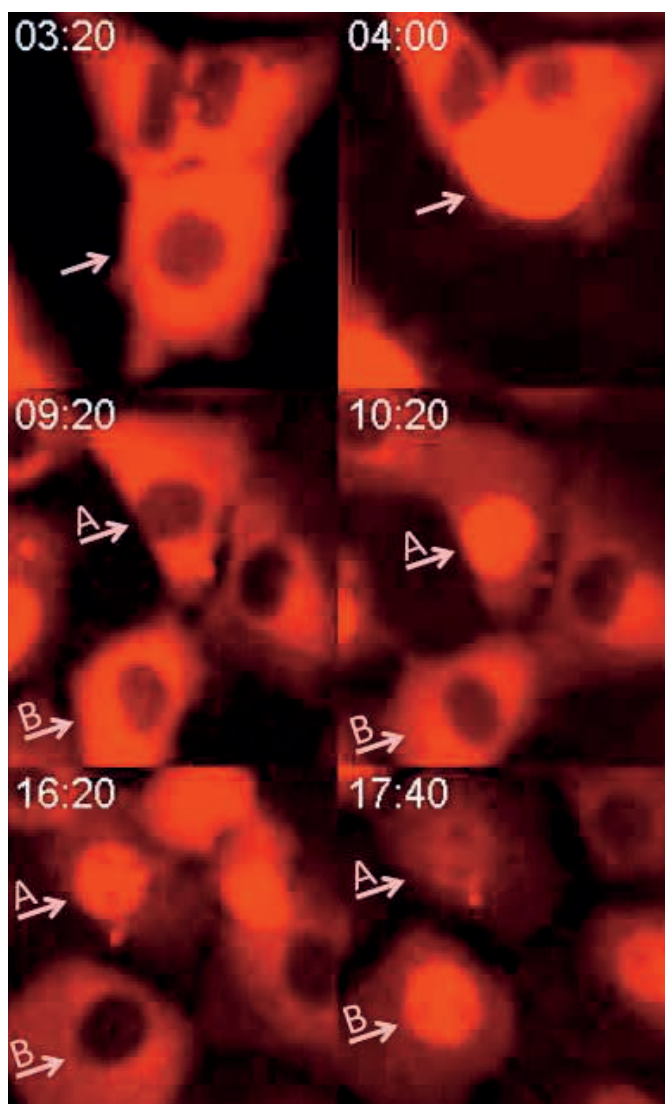

Temporal variability of signalling events in sister cells reveals stochasticity. Cells expressing IRF-7-RFP were infected with NDV and nuclear translocation was followed. A single cell (arrow) divides into two sister cells (A and B). Sister cells A react to virus infection with nuclear translocation of IRF-7 7 hours earlier than sister cells B. These data suggest variability in signalling by stochastic events rather than genetic events. HZI

Publications

Nandakumar, R., Finsterbusch, K., Lippsc C., Neumann, B., Grashoff, M., Nair, S., Hochnadel, I., Lienenklaus, S., Wappler, I., Steinmann, E., Hauser, H., Pietschmann, T., & Kröger, A. (2013) Hepatitis C Virus Replication in Mouse Cells is Restricted by IFN-Dependent and -Independent Mechanisms. *Gastroenterology*, doi:pii: S0016-5085(13)01230-4. 10.1053/j.gastro.2013.08.037. [Epub ahead of print]

Rand, U., Rinas, M., Schwerk, J., Nöhren, G., Linnes, M., Kröger, A., Flossdorf, M., Kály-Kullai, K., Hauser, H., Höfer, T., & Köster, M. (2012) Multi-layered stochasticity and paracrine signal propagation shape the type-I interferon response. *Molecular Systems Biology* **8**, 584. doi: 10.1038/msb.2012.17.

Ksienzyk, A., Neumann, B., & Kröger, A. (2012) IRF-1 is critical for IFN γ mediated immune surveillance. *Oncimmunology* **1**(4), 533-534.

Ksienzyk, A., Neumann, B., Nandakumar, R., Finsterbusch, K., Grashoff, M., Zawatzky, R., Bernhardt, G., Hauser, H., & Kröger, A. (2011) IRF-1 expression is essential for natural killer cells to suppress metastasis. *Cancer Research* **71**(20), 6410-6418. doi: 10.1158/0008-5472.

Datta, S., Hazari, S., Chandra, P.K., Samara, M., Poat, B., Gunduz, F., Wimley, W.C., Hauser, H., Koster, M., Lamaze, C., Balart, L.A., Garry, R.F., & Dash, S. (2011) Mechanism of HCV's resistance to IFN- α in cell culture involves expression of functional IFN- α receptor 1. *Virology Journal* **8**, 351. doi: 10.1186/1743-422X-8-351.



Project Leader

Prof. Dr. Lars Zender

former: Junior Research Group Chronic Infection and Cancer at HZI

current address: Division of Translational Gastrointestinal Oncology, University Hospital Tübingen

lars.zender@med.uni-tuebingen.de

Direct *InVivo* RNAi Screening for Therapeutic Targets to Increase Liver Regeneration

The liver harbours a distinct capacity for endogenous regeneration, however liver regeneration is often impaired in disease and, therefore, insufficient to compensate for the loss of hepatocytes and organ function. To identify potential targets for treating liver disease, we developed an unbiased screen to search for genes that regulate liver regeneration in animal disease models. After interfering with the expression of hundreds of genes in mouse livers, we found that MKK4 inhibition increased the regeneration and survival of hepatocytes after acute and chronic liver damage, resulting in healthier livers and an increase in the long-term survival of mice. Moreover, MKK4 inhibition increased the survival and long-term viability of hepatocytes in culture, offering a much-needed strategy for improving cell transplantation in patients with liver disease.

Pools of small hairpin RNAs (shRNAs) were directly and stably delivered into mouse livers to screen for genes modulating liver regeneration. The dual-specific kinase MKK4 as a master regulator of liver regeneration was identified. MKK4 silencing robustly increased the regenerative capacity of hepatocytes in mouse models of liver regeneration and acute and chronic liver failure. Mechanistically, induction of MKK7 and a JNK1-dependent activation of the AP1 transcription factor ATF2 and the Ets factor ELK1 are crucial for increased regeneration of hepatocytes with MKK4 silencing. HZI

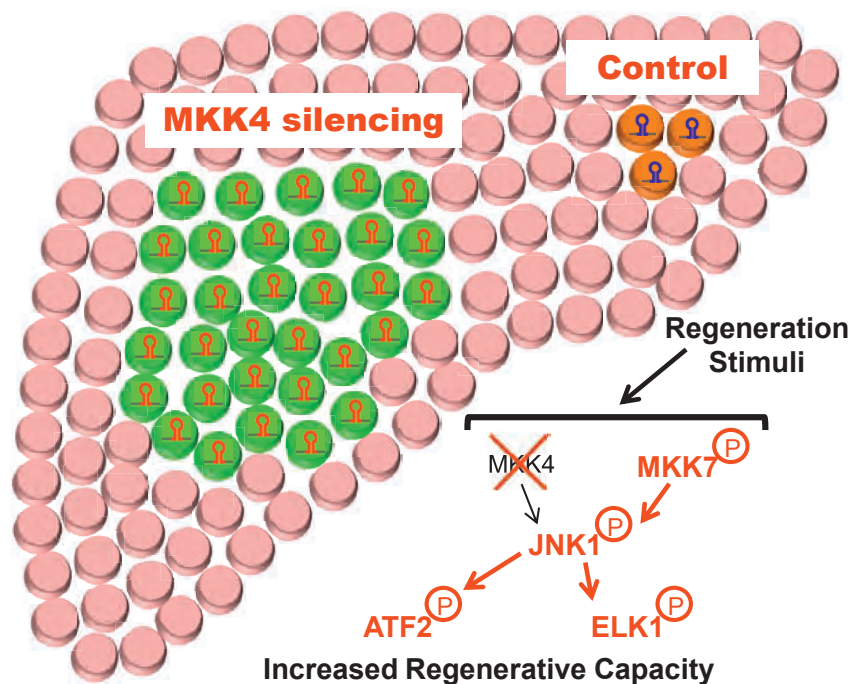

Highlights

Direct in vivo RNAi screening for modulators of liver regeneration is feasible

We established a system to conduct direct in vivo RNAi screens for genes that positively or negatively impact the regenerative capacity of hepatocytes. This system permits direct in vivo screening and target cells for shRNA expression, which are never taken out of their natural tissue microenvironment.

Identification of MKK4 as a master regulator of liver regeneration

We identified MKK4 as a master regulator of liver regeneration. MKK4 represents a dual-specific protein kinase that is essential for liver organogenesis. MKK4 inhibition in adult hepatocytes greatly enhances their proliferative and regenerative potential.

MKK4 is a potential therapeutic target in acute and chronic liver disease

MKK4 inhibition could mobilize regenerative reserves of hepatocytes under liver damage and showed robust therapeutic efficacy in mouse models of acute and chronic liver failure. Our data suggest that MKK4 suppression or altered function may contribute to tumour progression in some settings. We believe that a therapeutic window for transient and intermittent pharmacological MKK4 inhibition to increase liver regeneration exists.

In summary, we identified the dual-specific kinase MKK4 as a master regulator of liver regeneration. Our data shows that MKK4 inhibition increases the regenerative capacity of hepatocytes in settings of acute and chronic liver failure, and pharmacological MKK4 inhibitors may therefore represent a strategy for the treatment of patients with acute or chronic liver disease.



Project Members

Rishabh Chawla, Dr. Daniel Dauch, Jule Harbig, Florian Heinzmann, Lisa Hönicke, Anja Hohmeyer, Dr. Chih-Jen Hsieh, Dr. Tae-Won Kang, Marina Pesic, Ramona Rudalska, Katharina Wolters, Dr. Torsten Wüstefeld, Prof. Dr. Lars Zender

Publications

Wüstefeld T, Pesic M, Rudalska R, Dauch D, Longerich T, Kang TW, Yevsa T, Hei nzmann F, Hoenicke L, Hohmeyer A, Potapova A, Rittelmeier I, Jarek M, Geffers R, Scharfe M, Klawonn F, Schirmacher P, Malek NP, Ott M, Nordheim A, Vogel A, Manns MP, Zender L. A Direct in vivo RNAi screen identifies MKK4 as a key regulator of liver regeneration. *Cell*. 2013 Apr 11;153(2):389-401. doi: 10.1016/j.cell.2013.03.026. PubMed PMID: 23582328.

Wang J, Sun Q, Morita Y, Jiang H, Gross A, Lechel A, Hildner K, Guachalla LM, Gompf A, Hartmann D, Schambach A, Wüstefeld T, Dauch D, Schrezenmeier H, Hofmann WK, Nakauchi H, Ju Z, Kestler HA, Zender L, Rudolph KL. A differentiation checkpoint limits hematopoietic stem cell self-renewal in response to DNA damage. *Cell*. 2012 Mar 2;148(5):1001-14. doi: 10.1016/j.cell.2012.01.040. PubMed PMID: 22385964.

Liu L, Ulbrich J, Müller J, Wüstefeld T, Aeberhard L, Kress TR, Muthalagu N, Rycak L, Rudalska R, Moll R, Kempa S, Zender L, Eilers M, Murphy DJ. Deregulated MYC expression induces dependence upon AMPK-related kinase 5. *Nature*. 2012 Mar 28;483(7391):608-12. doi: 10.1038/nature10927. PubMed PMID: 22460906.

Xue W, Kitzing T, Roessler S, Zuber J, Krasnitz A, Schultz N, Revill K, Weissmueller S, Rappaport AR, Simon J, Zhang J, Luo W, Hicks J, Zender L, Wang XW, Powers S, Wigler M, Lowe SW. A cluster of cooperating tumor-suppressor gene candidates in chromosomal deletions. *Proceedings of the National Academy of Science USA*. 2012 May 22;109(21):8212-7. doi: 10.1073/pnas.1206062109. Epub 2012 May 7. PubMed PMID: 22566646; PubMed Central PMCID: PMC3361457.

Braumüller H, Wieder T, Brenner E, Abmann S, Hahn M, Alkhaled M, Schilbach K, Essmann F, Kneilling M, Griessinger C, Ranta F, Ullrich S, Mocikat R, Braungart K, Mehra T, Fehrenbacher B, Berdel J, Niessner H, Meier F, van den Broek M, Häring HU, Handgretinger R, Quintanilla-Martinez L, Fend F, Pesic M, Bauer J, Zender L, Schaller M, Schulze-Osthoff K, Röcken M. T-helper-1-cell cytokines drive cancer into senescence. *Nature*. 2013 Feb 21;494(7437):361-5. doi: 10.1038/nature11824. Epub 2013 Feb 3. PubMed PMID: 23376950.



Project Leader

Prof. Dr. Michael Meyer-HermannDepartment of Systems Immunology (SIMM)
michael.meyer-hermann@helmholtz-hzi.de

Systems Immunology

Steady state frequency of nodes of degree $k=1-3$ (red, green, blue) in dependence of the fusion and fission rates. Each pair of rates corresponds to a specific mitochondrial architecture, depicted in the black boxes. Generated by Valerii Sukhorukov, previously published in Sukhorukov et al, 2012. HZI

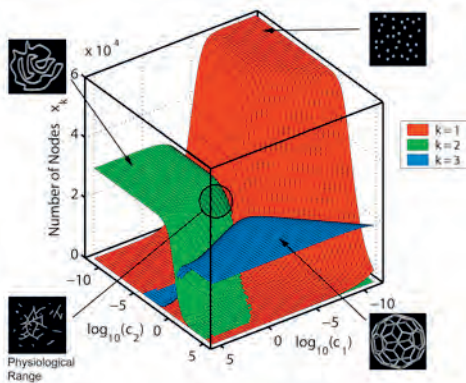

Photoactivation experiments in germinal centres *in silico*. Photoactivation in the LZ (upper row) and in the DZ (lower row) reveals asymmetric frequencies of transzone migration of B cells. Generated by Michael Meyer-Hermann, previously published in Meyer-Hermann et al, 2012. HZI

Systems Immunology describes the dynamics of the immune system with methods stemming from physics and mathematics. The project focus is on spatio-temporal multi-scale models of immune homeostasis, immune responses to pathogens, and deregulated immune responses in the context of diseases. The models help the understanding of mechanisms relevant for the dynamics of immune responses and help optimise disease treatment.

Mitochondrial network dynamics

Mitochondria are the key elements of energy supply in eukaryotic cells. Mitochondria organise as intracellular networks by fusion and fission. The dynamics of mitochondria fusion and fission is likely related to quality control of mitochondria but is not well understood. Starting from image analysis of confocal micrographs, we proposed a model for the network dynamics based on the simple processes of tip-to-tip and tip-to-side fusion and fission. Using an agent-based stochastic mathematical model a relation of the fusion and fission rates and the resulting mitochondrial network architecture could be identified. Interestingly, the network operates in the vicinity of a percolation threshold (Sukhorukov et al, 2012). This implies that cells can easily switch between fully fragmented and fully connected mitochondrial networks, as observed in the course of cell division. These results open a new perspective regarding mitochondria fragmentation during ageing.

Asymmetric division in germinal centres

Germinal centres are the sites of optimisation of antibodies for a specific pathogenic challenge and of memory formation, in particular, in the context of

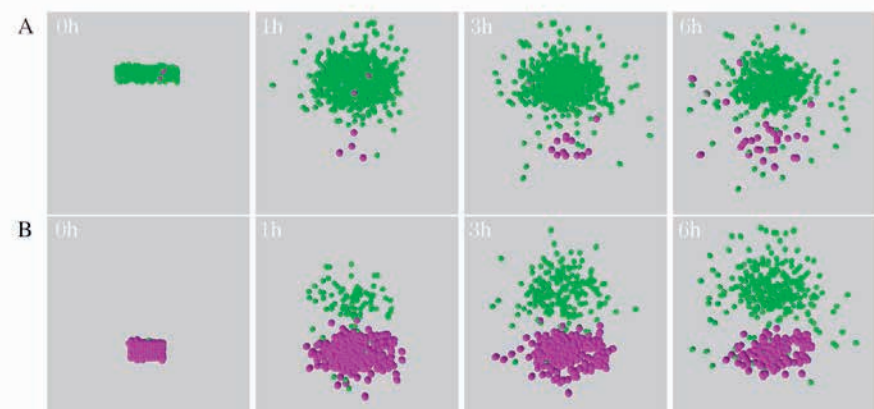

vaccination. Based on data from multi-photon imaging (Victoria et al, 2010) and asymmetric B cell division we have proposed a novel model of germinal centre B cell selection, division, and exit (Meyer-Herrmann et al, 2012), called the LEDA model, which predicts that B cells leave the germinal centre through the dark zone, in contrast to what was believed so far. It further shows that asymmetric division leads to faster generation of high-affinity clones (Meyer-Herrmann et al, 2012) and that this path induces a ten-fold larger population of antibody producing plasma cells (Dustin & Meyer-Herrmann, 2012). This result has major implications for the control of antibody responses and vaccination protocols.

Insulin carrying granule content of pancreatic β -cells

Pancreatic β -cells provide insulin in order to control metabolism. This is deregulated in type II diabetes. In a combined approach of electron microscopy, image analysis and 3D reconstruction of β -cells, we have found that the total amount of insulin carrying granules is more than two-fold less than taken for granted since 40 years (Fava et al, 2012) and that their size is substantially smaller. This result changes the view of how much insulin is carried by each granule and therefore redefines the impact of stimuli on insulin production and turnover.

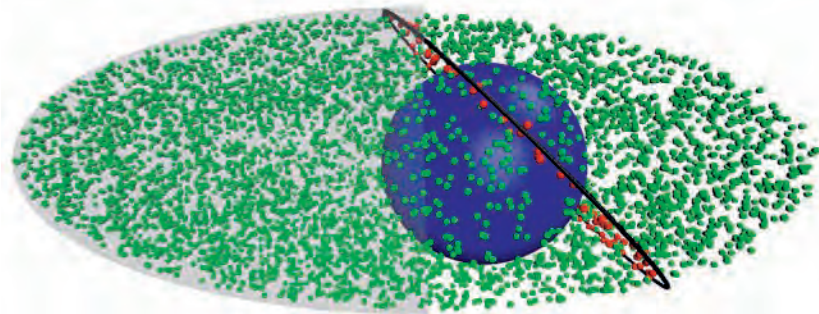

Project Members

Sebastian Binder, Florian Brennecke, Dr. Jaber Dehghany, Dr. Azadeh Ghanbari, Dr. Haralampos Hatzikirou, Matthias Haering, Prof. Dr. Michael Meyer-Herrmann, Steffen Mühle, Dr. Harald Kempf, Sahamoddin Khailaie, Philip Robert, Christine Schmeitz, Dr. Valerii Sukhorukov, Alexey Uvarovskij, Dr. Esteban Hernandez-Vargas, Dr. Gang Zhao

Granule in a virtual pancreatic beta-cell in 3D (left) and a quasi-2D slice (right), nucleus in blue, reveal their inhomogeneous distribution depending on the distance to the plasma membrane. Generated by Jaber Dehghany, previously published in Fava & Dehghany et al, 2012 HZI

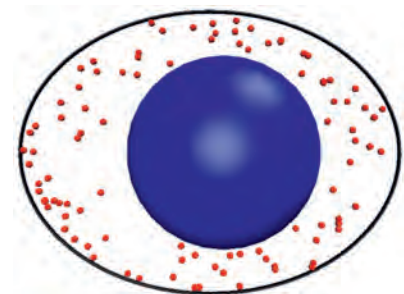

- Mitochondrial networks of eukaryotic cells function in the vicinity of a percolation threshold. Implications of this result on mitochondria quality control will be investigated.
- Asymmetric division and exit through the dark zone of germinal centre B cells induces faster and ten-fold stronger antibody responses. These results will be used to identify ways of improving antibody responses.
- Insulin carrying granules in pancreatic β -cells are less and smaller than believed so far. These results will be used to model the motility and the exocytosis dynamics of granules in β -cells with the aim of improving insulin turnover.

Publications

- Sukhorukov, V., Dikov, D., Reichert, A.S., & Meyer-Herrmann, M. (2012) Emergence of the mitochondrial reticulum from fission and fusion dynamics. *PLoS Computational Biology* **8**(10), e1002745.
- Victoria, G.D., Schwickert, T.A., Fooksman, D.R., Meyer-Herrmann, M., Dustin, M.L., & Nussenzweig, M.C. (2010) Germinal center selection mechanism revealed by multiphoton microscopy using a photoactivatable fluorescent reporter. *Cell* **143**, 592-605.
- Meyer-Herrmann, M., Mohr, E., Pelletier, N., Zhang, Y., Victoria, G.D., & Toellner, K.-M. (2012) A theory of germinal center B cell selection, division and exit. *Cell Reports* **2**, 162-174.
- Dustin, M.L., & Meyer-Herrmann, M. (2012) Antigen feast or famine. *Science* **335**, 408-409.
- Fava, * E., Dehghany, * J., Ouwendijk, J., Müller, A., Niederlein, A., Verkade, P., Meyer-Herrmann, * M., & Solimena, * M. (2012) Novel standards in the measurement of insulin granules combining electron microscopy, high-content image analysis and in silico modelling. *Diabetologia* **55**, 1013-1023. [*shared first and shared corresponding author]



Project Leader

Prof. Dr. Dr. Luka Cicin-Sain

Junior Research Group Immune Aging and
Chronic Infections (IMCI)

lcs09@helmholtz-hzi.de

Effect of Chronic Infections on the Adaptive Immune System

Epidemiological longitudinal studies of elderly volunteers identified immune-risk phenotypes that predicted poor survival, and these phenotypes coincided with seropositivity to cytomegalovirus (CMV). If a ubiquitous agent, such as CMV, would contribute to immune aging, this would have a huge impact on our understanding of the immune aging process in the general population. We have developed an *in vivo* model that allows us life-long immune monitoring of mice and we have used it to monitor the effect of CMV infection on the aging host.

CMV results in a significant increase of effector memory CD8 cells in the blood and spleen and of central memory CD8 cells in the lymph nodes of virus-infected mice. These increases are permanent because they are maintained upon the clearance of lytically replicating virus from the blood. Challenge of CMV-infected mice with emerging pathogens, such as the influenza or the West-Nile Virus, resulted in CD8 T-cell responses to the novel pathogen which were significantly reduced as compared to littermate controls which were not CMV infected. While the mechanism of this phenomenon remained elusive, we observed that CD8 T-cell recruitment and/or activation in the draining lymph nodes of CMV infected mice was reduced as compared to control mice (results published this year in PLOS Pathogens).

Immune dominance to CMV antigens critically depends on the context of gene expression. Immune responses to the SSIEFARL peptide upon infection with recombinant MCMVs expressing the peptide in the context of the immediate-early 2 gene (MCMVie2SL) or the M45 gene (MCMVM45SL) were measured in the CD8 subset of blood T-lymphocytes. Blood was harvested at day 180 post infection, leukocytes were in vitro re-stimulated with the SSIEFARL peptide for 6 h, and the fraction of CD8 T-cells responding to the peptide was measured by intracellular staining for interferon gamma (IFN γ) production. Numbers indicate the percentage of CD8 T-cells in the IFN γ positive gate adapted from

Dekhtiarenko et al. *J. Immunol.* 2013



More recently we identified the accumulation of memory CD8 cells as a major contribution to the weak responses to superinfecting pathogens. Namely, depletion of memory CD8 cells, by means of monoclonal antibody depletion resulted in a vigorous increase of relative and absolute counts of blood CD8 cells responding to challenge with Vesicular stomatitis virus. These effects were restricted to the CD8 compartment, as there was no loss in CD4 responses and were restricted to the CMV infection, because infections with other herpesviruses did not compromise the immune response upon challenge. Efforts to characterize the responses in various lymphatic compartments (*e.g.* spleen, lymph nodes, bone-marrow) are underway.

In parallel we have identified a novel mechanism by which the CMV evades the immune system. We showed that MCMV causes disease and death in mice lacking lymphocytes because its gene M36 blocks programmed cell death, or apoptosis. MCMV lacking the M36 gene grew thousand folds less well in these mice, which significantly improved survival. This was because M36 deletion made MCMV susceptible to the action of macrophages, cells that secrete soluble factors inducing apoptosis. Importantly, viral growth and virulence of the M36-deficient MCMV could be restored by blocking apoptosis by other means, showing that the block of apoptosis was critical for viral replication. Therefore, our data implies that viral inhibition of apoptosis may be a key molecular target for antiviral strategies in immunodeficient hosts.

- CMV infection induces a strong and permanent accumulation of effector/memory CD8 cells which impairs CD8 responses to challenge with live virus.
- To study the molecular mechanisms of this phenomenon we need to define the organs in which the changes take place.
- CMV blocks death-receptor apoptosis and thus protects itself from the antiviral activity of macrophages.
- It remains unclear if this mechanism impairs the antiviral activity of CD8 cells, which is part of our ongoing efforts.



Project Members

Dr. Lisa Borkner, Dr. Rosaely Casalegno-Garduno, Prof. Dr. Luka Cicin-Sain, Franziska Dag, Iryna Dekhtiarenko, Anja Drabig, Dr. Linda Ebermann, Julia Holzki, Dr. Bahram Kasmapour, Thomas Marandu, Jennifer Oduro, Dr. Adrien Weingärtner, Jennifer Wolf

Publications

Cicin-Sain, L., Hagen, S., Sylwester, A., Siess, D., Currier, N., Legasse, A., Fischer, M.B., Koudelka, C., Mori, T., Axthelm, M.J., Nikolich-Zugich, J., & Picker, L.J. (2011) Cytomegalovirus-Specific T-cell Immunity Is not Compromised in Old Rhesus Monkeys. *Journal of Immunology* **187**(4),1722-2732.

Cicin-Sain, L., Brien, J.D., Uhrlaub, J., Drabig, A., Marandu, T.F., & Nikolich-Zugich, J. (2012) Cytomegalovirus Infection Impairs Immune Responses and Accentuates T-cell pool Changes Observed in Aging Mice. *PLoS Pathogens* **8**, e1002849.

Solana, R., Tarazona, R., Aiello, A.E., Akbar, A.N., Appay, V., Beswick, M., Bosch, J.A., Campos, C., Cantisán, S., Cicin-Sain, L., Derhovanessian, E., Ferrando-Martínez, S., Frasca, D., Fulöp, T., Govind, S., Grubeck-Loebenstein, B., Hill, A., Hurme, M., Kern, F., Larbi, A., López-Botet, M., Maier, A.B., McElhane, J.E., Moss, P., Naumova, E., Nikolich-Zugich, J., Pera, A., Rector, J.L., Riddell, N., Sanchez-Correa, B., Sansoni, P., Sauce, D., van Lier, R., Wang, G.C., Wills, M.R., Zielinski, M., & Pawelec, G. (2012) CMV and Immunosenescence: from basics to clinics. *Immunity & Ageing* **9**(1), 23 (ePub ahead of Print).

Ebermann, L., Ruzsics, Z., Casalegno-Garduno, R., Guzmán, C.A., van Rooijen, N., Koszinowski, U., & Cicin-Sain, L. (2012) Block of Death-Receptor Apoptosis Protects Mouse Cytomegalovirus from Macrophages and is a Determinant of Virulence in Immunodeficient Hosts. *PLoS Pathogens* **8**, e1003062.

Dekhtiarenko I., Jarvis M.A., Ruzsics Z., Cicin-Sain L*. 2013 The Context of Gene Expression Defines the Immunodominance Hierarchy of CMV Antigens. *Journal of Immunology* 190(7):3399-409



Project Leader

Prof. Dr. Ulrich Kalinke

Research Group: Experimental Infection Research (EXPI) | ulrich.kalinke@twincore.de

Group leader: **Priv.-Doz. Dr. Frank Pessler**

Research Group: Biomarkers in Infectious Diseases | frank.pessler@twincore.de

Interaction between Innate and Adaptive Immunity

Usually, within hours following viral infection, type I interferon responses are induced which secure the initial survival of the host. It is approximately a week later that adaptive immunity is activated to an extent that it is able to eradicate the infecting pathogen. In earlier studies we found that upon viral infection a small number of highly specialised immune cells, also addressed as plasmacytoid dendritic cells (pDC), produce large quantities of protective type I interferon. Practically, all viruses that were examined more closely developed countermeasures that inhibit the induction or the function of such type I interferon responses. We are investigating how different viruses induce type I interferon responses, which strategies they deploy to undermine these responses and how interferons secure the survival of the host.

Fig. 1. Upon MVA challenge, depletion of CD4⁺ T cells (anti-CD4 treatment on day -2 and -1) significantly reduces the expansion of virus-specific CD8⁺ T cells (Kremer et al., 2012). In previous studies we found that also type I interferon signalling was needed for efficient T cell expansion. These experiments illustrate, that (i) MVA treatment induces massive expansion of antigen-specific T cells resulting in more than 20% of all endogenous CD8⁺ T cells being antigen-specific, and that (ii) T cell expansion not only depends on type I interferon as a third signal but also on the provision of sufficient T_{help}. These results qualify MVA as an excellent vaccination vector. HZI

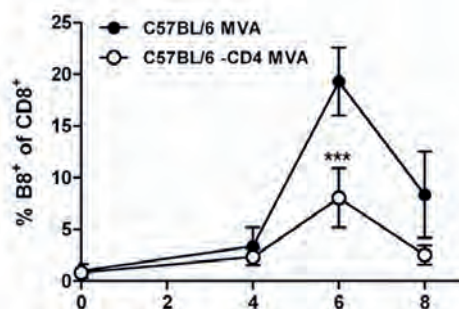
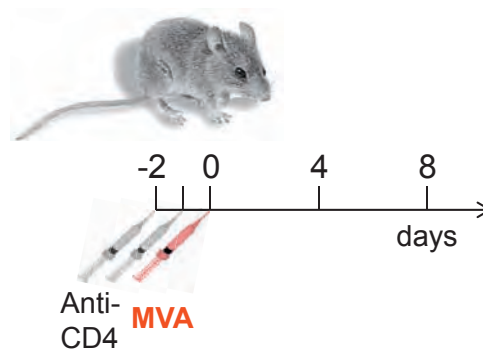

Mechanisms of type I interferon induction and its protective function

The molecular mechanism of type I interferon induction may vary depending on the inducing agent and the analysed tissues or cells. We study in the mouse model how viruses are recognized by cross-talk of Toll-like receptors and RIG-I like helicases and how the resulting type I interferon responses inhibit the entry of the vesicular stomatitis virus (VSV) into the central nervous system. Furthermore, we analyse which influence type I interferon responses may have on immune cell functions. In this context, we found that the attenuated vaccinia virus variant “modified vaccinia virus (MVA)” triggers strong type I interferon responses, which play a crucial role in the expansion of virus-specific T cells. Under such conditions, in addition to type I interferon stimulation of antigen-presenting dendritic cells and T cells, provision of T_{help} is needed (also see Fig. 1). Moreover, we investigate the influence of virus-induced type I interferon on hematopoietic stem cells and on the induction of long-lasting antibody responses. This work plays an important role for the development of new vaccination strategies.

Hepatitis C virus-mediated activation of human pDC

Depending on the genotype of hepatitis C virus (HCV), chronically infected patients show different response rates to interferon-alpha / ribavirin combination therapy. So far it is unclear whether acute HCV infection sufficiently triggers the body's own interferon system and whether different HCV variants induce interferon responses of different magnitudes. We investigate HCV and / or host encoded factors influencing the strength and composition of HCV-induced cytokine responses of human pDC. This work is carried out *in vitro* with primary human pDC isolated from blood samples from healthy donors. In the future also experiments with pDC from chronically HCV infected patients.

An improved understanding of the multiple functions of type I interferon can help to optimize type I interferon-based therapies of tumours, autoimmune diseases and viral infections. Furthermore, deeper knowledge of the viral mechanisms of immune stimulation and evasion will provide new approaches for vaccine development.



Project Members

Patrick Bartholomäus, Patrick Blank, Katharina Borst, Daniela Buschjäger, Chintan Chhatbar, Dr. Claudia Detje, Marius Döring, Dr. Theresa Frenz, Dr. Elena Grabski, Sabrina Heindorf, Julia Heinrich, Christoph Hirche, Prof. Dr. Ulrich Kalinke, Annett Keßler, Jennifer Knaak, Christian Mers, Mohammed Nooruzzaman, Jennifer Paijo, Dr. Claudia Soldner, Stephanie Vogel



Priv.-Doz. Dr. Pessler and his team (from left to right): Dr. Mahmoud Bahgat Riad, Frank Pessler, Mohammed Samir, Jens Schneider, Mohammed Tantawy

Baranek, T., Manh, T.P., Alexandre, Y., Maqbool, M.A., Cabeza, J.Z., Tomasello, E., Crozat, K., Bessou, G., Zucchini, N., Robbins, S.H., Vivier, E., Kalinke, U., Ferrier, P., & Dalod, M. (2012) Differential responses of immune cells to type I interferon contribute to host resistance to viral infection. *Cell Host Microbe* **12**(4), 571-584.

Kremer, M., Suezzer, Y., Volz, A., Frenz, T., Majzoub, M., Hanschmann, K.M., Lehmann, M.H., Kalinke, U., & Sutter, G. (2012) Critical role of perforin-dependent CD8+ T cell immunity for rapid protective vaccination in a murine model for human smallpox. *PLoS Pathogens* **8**(3), e1002557.

Chopy, D., Detje, C.N., Lafage, M., Kalinke, U., & Lafon, M. (2011) The type I interferon response bridges rabies virus infection and reduces pathogenicity. *Journal of Neurovirology* **17**(4), 353-367.



Project Leader

Dr. Andrea Scrima

Junior Research Group Structural Biology
of Autophagy (SBAU)
andrea.scrima@helmholtz-hzi.de

Structural Biology of Autophagy in Infection and Disease

Autophagy is a cellular process that is dedicated to the degradation of intracellular components. Autophagy activation leads to the formation of autophagosomes, specialized double membrane structures, which engulf cytoplasmic components and subsequently fuse with lysosomes, resulting in degradation of the engulfed cargo. Initially identified as a starvation induced process in yeast, autophagy has recently been shown to be involved in a large number of immunity-related processes in mammalian cells. Defects in autophagy have been implicated with cancer, neurodegeneration and chronic inflammatory diseases of the intestine. Autophagy emerged as powerful cellular defense mechanism to counteract infections and mediate pathogen clearance by direct engulfment and degradation via autophagy. However, various pathogens have evolved strategies not only to evade autophagic detection and degradation, but also to exploit autophagy for their own benefit. Despite the current research on autophagy, the basic processes that regulate different stages of autophagy, as well as the strategies pathogens use to evade or exploit autophagy, are not well understood. Using X-ray crystallography in combination with proteomics, biochemical/biophysical and cell biological methods, we want to gain an insight into the central processes in autophagy and the pathogenic evasion mechanisms.

Left: The autophagy pathway

Deretic & Levine, Cell Host & Microbe 2009, modified)

Right: Crystals of a regulatory ATG-protein

Photo: Stefan Leupold

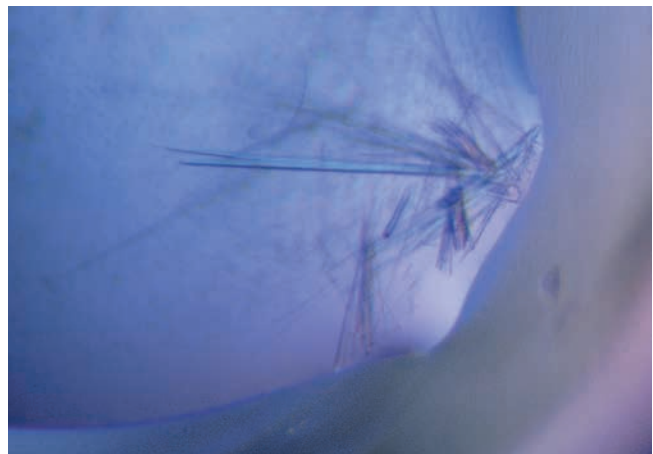
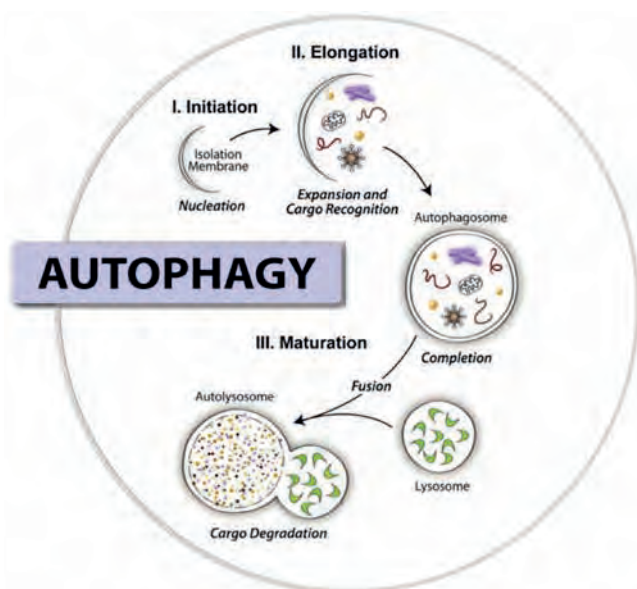

Regulation of autophagy

Autophagy is controlled by more than 30 autophagy proteins of the ATG-protein family. In order to understand how pathogens exploit autophagy and evade from autophagic detection and degradation, we first have to shed light onto the basic regulatory processes of autophagy controlled by the ATG-proteins during infection. Thus, we are currently investigating the interplay of the key regulatory ATG-proteins with cellular and pathogenic proteins in autophagy during infection with a particular focus on protein-protein interactions and post-translational modifications.

Pathogenic strategies to counteract or exploit autophagy

The co-evolution of pathogens and the human host has led to the development of sophisticated strategies used by pathogens to specifically counteract or even exploit the host cell defense mechanism autophagy. These strategies are not restricted to bacterial pathogens, such as *Shigella spp.*, *Listeria monocytogenes* and *Staphylococcus aureus*. Viral pathogens including herpesviruses, human immunodeficiency virus-1, influenza A virus and Hepatitis C virus have evolved a set of tools to modulate autophagy at various stages as well. We are currently expressing and purifying target proteins from pathogens that modulate autophagy and aim at structurally and biochemically characterizing their function in the context of host cell defense by autophagy and immune evasion.

The structural and functional characterization of host-derived and pathogenic proteins will greatly contribute to our understanding of pathogenic immune evasion strategies and may help to find novel ways of treatment of infectious diseases. Using a combination of protein biochemistry/ proteomics, cell and structural biology, we aim at:

- Analysing regulatory mechanisms in autophagy
- Understanding pathogen detection mechanisms at the molecular level
- Unravelling the structural basis of pathogenic evasion mechanisms
- Utilizing the gained knowledge to interfere with pathogenic evasion processes



Project Members

Archna, Milica Bajagic, Stefan Leupold, Dr. Stefan Schmelz, Dr. Andrea Scrima



Project Leader

Dr. Dagmar Wirth

Research Group Model Systems for Infection and Immunity (MSYS)
dagmar.wirth@helmholtz-hzi.de

Cellular Models

In this group we investigate the host response to infection with new experimental systems. *In vitro* cell systems as well as novel mouse models are specifically engineered with the aim to reflect natural processes. Thereby, novel experimental approaches are enabled to elucidate specific questions in infection biology.

Growth controlled cellular infection systems

To expand mammalian cells on command, we recently designed a strategy that enables controlled proliferation of cells. Primary cells of various species and differentiation states are immortalized upon lentiviral (co-)transduction of selected proliferation genes. Infected cells become immortalized and are characterized with respect to the cell type specific features. To timely restrict the action of the proliferator genes we employ expression modules that can be externally controlled by addition of Doxycycline. Importantly, since cellular proliferation is strictly dependent on Doxycycline, control of cell growth can be achieved. This allows expanding cell populations on command.

Conditionally immortalized endothelial cells form tube like structures in Matrigel (A). Upon transplantation into immune compromised mice, conditionally immortalized human endothelial cells form perfused vessels (B). Engraftment of luciferase tagged cells is detected upon staining with an anti-luciferase antibody (C). ^{HZI}

Following this strategy, we immortalized endothelial cells from mouse and man. The phenotypic properties and the function were confirmed *in vitro*. Moreover, the cells could be transplanted into immunodeficient mice and could establish functional vessels. Further, we investigated if these cells could be used as novel model systems for pathogens that specifically infect endothelial cells. We could show that HUVEC derived conditionally immortalized cells are readily infected

A

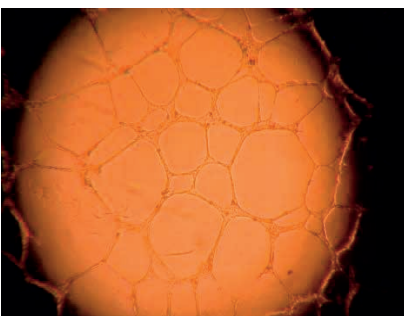

B

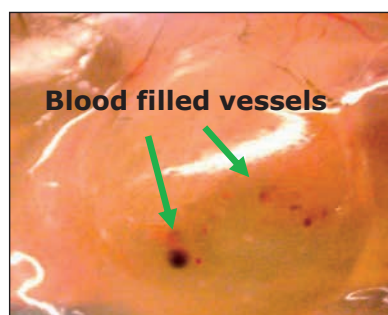

C

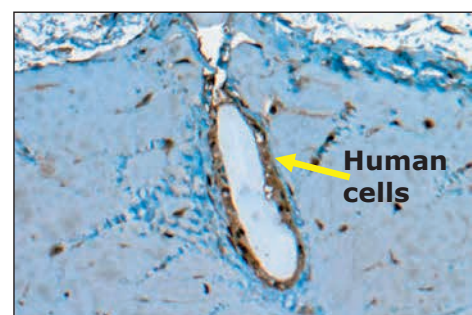

with Kaposi's sarcoma-associated herpesvirus (KSHV) as well as group A streptococci. Accordingly, conditionally immortalized liver endothelial cells from mouse can be infected with mouse cytomegalovirus (MCMV). These proliferation controlled cell lines represent model systems to elucidate the pathogenic mechanisms in controlled conditions as well as for screening approaches.

Mouse models for infection

Recently, we established murine embryonic stem cell lines in which the ubiquitously expressed Rosa26 locus is tagged with FRT sites. By Flp recombinase mediated cassette exchange (RMCE), cassettes can be specifically integrated into this chromosomal site with high efficiency (Sandhu et al., 2011). Various constitutive and inducible expression cassettes were validated in this site thereby allowing prediction of the expression characteristics in transgenic mice. Using this technology, we generated mouse models for tissue specific and inducible antigen expression that mimic hepatotropic viral antigen expression upon infection.

Prevention of microbial biofilms on medical implants

Another activity concern aims at developing strategies to prevent infections of medical implants. Slow release coatings were developed with the aim to provide bactericidal activity for a critical period after implantation. Several different strategies were employed. The most efficacious coatings were obtained from antibiotic loaded structured nanoparticle suspensions. These prevented infections by *P. aeruginosa* for over one week after implantation.

- Novel cell lines providing growth control serve as novel cellular models for infection and for screening
- Fast track to generate transgenic mouse models with predictable expression
- Improvement of medical implants by obviating microbial biofilms



Project Members

Dr. Muhammad Badar, Dr. Marcin Cebula, Dr. Pratibha Gaur, Dr. Upneet Hillebrand, Natascha Kruse, Christoph Lipps, Daniel Maeda, Aaron Ochel, Prof. Dr. Peter-Paul Müller, Shawal Spencer, Dr. Dagmar Wirth, Lisha Zha

Publications

- Sandhu, U., Cebula, M., Behme, S., Riemer, P., Wodarczyk, C., Reimann, J., Schirmbeck, R., Hauser, H. & Wirth, D. (2011) Strict control of transgene expression in a mouse model for sensitive biological applications. *Nucleic Acids Research* **39**(1), e1.
- Nehlsen, K., Herrmann, S., Zauers, J., Hauser, H. & Wirth, D. (2010) Toxin-antitoxin based transgene expression in mammalian cells. *Nucleic Acids Research* **38**(5), e32.
- May, T., Butueva, M., Bantner, S., Markusic, D., Seppen, J., Weich, H., Hauser, H., & Wirth, D. (2010). Synthetic gene regulation circuits for control of cell expansion. *Tissue Engineering Part A*. **16**(2), 441-452.
- Nehlsen, K., Schucht, R., Gama-Norton, L., Kromer, W., Baer, A., Cayli, A., Hauser, H. & Wirth, D. (2009) Recombinant protein expression by targeting pre-selected chromosomal loci. *BMC Biotechnology* **9**, 100.
- Mueller, P.P., Arnold, S., Badar, S., Bormann, D., Haferkamp, H., Drynda, A., Meyer-Lindenberg, A., Hauser, H., & Peuster, M. (2012) Vascular iron implant degradation kinetics, corrosion product localization and transcriptional response in a novel murine model. *Journal of Biomedical Materials Research: Part A*, in press.

The G-Swab study (G = “gold standard”)

This study (n=84) was conducted during the 2010/11 ARI season in order to compare pathogen detection rates in staff-collected and self-collected nasal swabs. Staff- and self-collected nasal swabs were obtained during ARI episodes in parallel from the participants and a trained staff member. Laboratory analyses demonstrated full equivalence of staff- and self-collected swabs.

The s-Swab study (s = “serial”) is included among the projects described on page 126-127 (Dept. of Epidemiology)

Infection risk questionnaire

A short (<10 minutes) questionnaire was devised to assess human susceptibility to a variety of common acute infections, including ARIs.

Micro RNAs in the host response to acute respiratory infection

miRNAs are small RNAs that play regulatory roles in nearly all aspects of biology and can be detected in tissue and blood samples that have been stored for several years. We are evaluating the expression of miRNAs in the host response to acute viral respiratory infections, aiming to identify miRNAs that play key roles in host defense and can also serve as markers for diagnosis and risk stratification of patients. Using lung tissue from inbred mouse strains with different susceptibility to influenza A virus infection, we are searching for miRNAs that are differentially regulated during infection and might also relate functionally to the host response against the virus.

Using lung tissue from different inbred mouse strains infected with influenza A virus, we found that miR-155-5p and miR-223-3p are induced within 48h of infection; importantly, both were induced to higher levels in the more susceptible (DBA/2J) than the resistant strain (C57B/6J). Using deep sequencing of small RNAs (RNAseq) to profile differential expression of miRNAs, we identified additional miRNAs that are induced during influenza A virus infection. In general, significantly regulated miRNAs were more abundant in the DBA/2J mouse strain.

We have developed cost-effective tools for epidemiological field research on respiratory infections in humans. We are now getting ready to apply these tools to large population-based studies, such as the National Cohort, in order to identify individuals with increased susceptibility to acute respiratory infections and to then search for the corresponding genetic and epigenetic determinants.

We have identified several miRNAs that are induced during influenza A virus infection in mice. We are now planning to evaluate their human counterparts as biomarkers for early diagnosis and/or risk stratification in influenza infection.



Project Members

Dr. Manas Akmatov, Priv.-Doz. Dr.
Frank Pessler, Matthias Preusse



Collection of a nasal swab. The soft tip of the swab is inserted into the anterior naris to obtain secretions that may contain particles of the causative virus. HZI

Publications

Akmatov, M.K., & Pessler, F. (2011) Self-collected nasal swabs to detect infection and colonization: a useful tool for population-based epidemiological studies? *International Journal of Infectious Diseases* **15**, e589-593.

Akmatov, M.K., Krebs, S., Preusse, M., Gatzemeier, A., Frischmann, U., Schughart, K. & Pessler, F. (2011) E-mail-based symptomatic surveillance combined with self-collection of nasal swabs: A new tool for acute respiratory infection epidemiology. *International Journal of Infectious Diseases* **15**, e799-803.

Von Jagwitz, M., Pessler, F., Akmatov, M., Li, J., Range, U., & Vogelberg, C. (2011) Reduced breath condensate pH in asymptomatic children with prior wheezing as a risk factor for asthma. *Journal of Allergy and Clinical Immunology* **128**, 50-55.

Akmatov, M., Gatzemeier, A., Schughart, K., & Pessler, F. (2012) Equivalence of self- and staff-collected nasal swabs for the detection of viral respiratory pathogens. *PLoS One* **11**, e48508.

Preusse, M., Della Beffa, C., & Pessler, F. (2013) Profiling of miRNA expression: spotlight on RNA sequencing. In: miRNAs in Medicine *Transworld Research Network*.



Project Leader

Prof. Dr. Martin Korte

Research Group Neuroinflammation and Neurodegeneration (NIND)
m.korte@tu-bs.de
martin.korte@helmholtz-hzi.de

Further Project Members

Dr. Anita Remus, Marianna Weller

Infection, Neuroinflammation and Neurodegeneration: A Highly Complex Interdependency

The focus of our group is to determine the influence of an infection and of the immune system on the onset and on the progression of neurodegenerative diseases. Particularly, we are investigating the role of the initiation and regulation of inflammatory processes and their involvement in the development of the Alzheimer's disease (AD). Thus, better understanding of the influence exerted by the immune system on the onset of neurodegenerative processes could improve the therapeutic approach in neurodegenerative disease.

Neurodegenerative diseases are the result of a progressive impairment in the structure and the function of neurons, leading to their death and resulting in an impairment of neurological functions, like memory loss. Learning and memory processes are most likely accomplished via activity-dependent changes in the strength of synapses called synaptic plasticity, which is investigated in our laboratory since many years. Taken together, we think that an inflammatory reaction may have detrimental effects on the central nervous system and we are applying two approaches to test this hypothesis:

1. Together with Dr. Ildiko Dunay/Prof. Drik Schlüter (University of Magdeburg) we study direct infections of the CNS caused by infection with *Toxoplasma gondii*.
2. In cooperation with the Prof. Michael Heneka (University of Bonn/DZNE) we are using different infection mouse models to analyse the initial phase and/or the progression of AD due to inflammatory responses due to a sepsis. Our working hypothesis is that an improper inflammatory response may lead to neurodegeneration through the activation of an inflammasome, which is responsible for activation of inflammatory processes. In the case of AD the activation of the inflammasome might result in negative effects on neurons and glia cells of the central nervous system. To assess the effect of NLRP3-inflammasome deficiency on neuronal function and structure in a murine model of AD, we determined

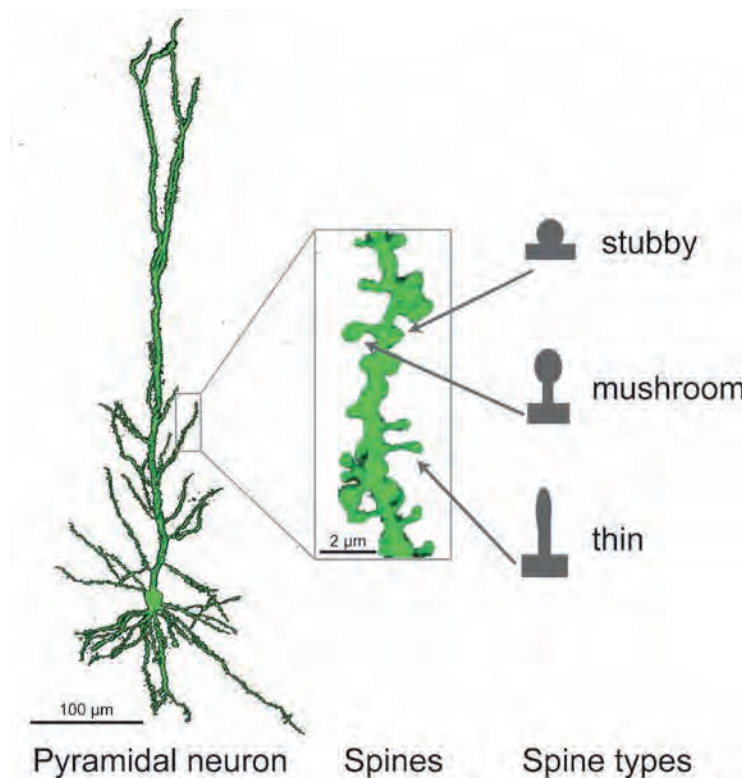

Picture of a typical CA1 pyramidal neuron of the hippocampus showing its very complex dendritic tree. In the insert a high magnification image of the dendrite showing several dendritic spines. Spines can be classified in thin-, mushroom- and stubby-type spines. HZI

hippocampal synaptic plasticity by measuring long term potentiation (LTP) and studying in detail the neuronal morphology (dendritic complexity, spine number and shape). NLRP3 deficiency completely prevented LTP suppression in hippocampal slices from APP/PS1 mice, a mouse model for AD typically showing memory impairment. An analysis of spine morphology revealed significant reduction of spine density in the pyramidal neurons of APP/PS1 mice, which was again prevented by NLRP3 deficiency (Heneka et al., 2013). These results reveal an important role for the NLRP3 in AD pathogenesis, and suggest that NLRP3 inflammasome inhibition might represent a novel therapeutic intervention for AD. It is also noteworthy, that this study implies that the inflammatory response might not only be important in the last phase of AD, but might also be involved in the origin of the disease. This is indicated by the fact, that different molecular species of A β , a peptide known as component of amyloid plaques associated with AD, might have a different toxicity. Indeed, we could show, again with the Heneka lab, that A β is changed to the more toxic form so called nitrosylated A β after Nitric oxide (NO) action, which is produced by immune cells in the brain that are activated as an inflammatory response (Kummer et al., 2011).

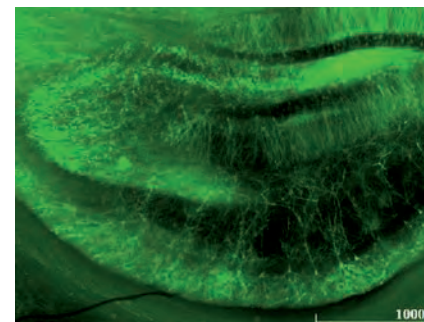

Acute hippocampal slice of a transgenic mouse showing GFP-fluorescent hippocampal neurons. HZI

Publications

Heneka, M.T., Kummer, M.P., Stutz, A., Delekate, A., Schwartz, S., Saecker, A.V., Griep, A., Axt, D., Remus, A., Tzeng, T.-C., Gelpi, E., Halle, A., Korte, M., Latz, E., & Golenbock, D. (2013) NLRP3 is activated in Alzheimer's disease and contributes to pathology in APP/PS1 mice. *Nature*, DOI: 10.1038/nature11729.

Kummer, M.P., Hermes, M., Delekate, A., Hamerschmidt, T., Kumar, S., Terwel, D., Walter, J., Pape, H.-C., König, S. Roeber, S., Jessen, F., Klockgether, T., Korte, M., & Heneka, M.T. (2011) Nitration of tyrosine 10 critically enhances amyloid beta aggregation and plaque formation. *Neuron* **71**(5), 833-844.

Delekate, A., Zagrebelsky, M., Kramer, S., Schwab, M.E., & Korte, M. (2011) Nogo-A restricts synaptic plasticity in the adult hippocampus on a fast time scale. *PNAS* **108**, 2569-2574.

Zagrebelsky, M., Schweigreiter, R., Bandtlow, C.E., Schwab, M.E. & Korte, M. (2010) Nogo-A stabilizes the architecture of hippocampal neurons. *Journal of Neuroscience* **30**, 13220-13234.

Korte, M., Carroll, P., Wolf, E., Brem, G., Thoenen, H., & Bonhoeffer, T. (1995) Hippocampal long-term potentiation is impaired in mice lacking brain-derived neurotrophic factor. *PNAS* **92**, 8856-8860.



Project Leader

Priv.-Doz. Dr. Gerhard Gross

Department of Gene Regulation and
Differentiation (RDIF)

gerhard.gross@helmholtz-hzi.de

Inflammation and Regeneration

Infection of tissues, trauma, shock and sepsis induce a severe inflammatory response. In contrast to acute inflammation, chronic inflammation leads to a progressive shift in the type of cells which are present at the site of inflammation and, in general, leads to the destruction of the tissue in or near the inflammatory process.

We follow the hypothesis that inhibition of the inflammatory signalling cascades will allow the design of new anti-inflammatory and therapeutic modalities. We investigate the role of caveolin-1 in inflammation in general and in virus infection in particular. Cav-1 represents a multifaceted membrane protein. It interacts with the human influenza virus (IAV) M2 matrix protein and supports virus production in MDCK cells. We found that Cav-1 restricts influenza A virus propagation in mouse fibroblasts. In line with the investigation on IAV restriction a new suspension duck cell line (sEFB1) could be established that gives rise to high titer of IAV particles (in cooperation with V. Jäger, RPEX). Thus, Cav-1 has the potential to serve as a new target for therapeutic intervention.

Rheumatoid arthritis (RA) is a severe chronic, systemic, inflammatory and autoimmune disorder that may affect many tissues and organs. This disorder may lead to a substantial loss of mobility and patients suffer from serious pain and are afflicted by an increased mortality. It is well known that multipotent

Murine lymphocytes (spleen; blue) adhere to an activated mesenchymal stem cell (MSC; green). MSCs were treated with LPS inducing an inflammatory response.

HZI / Manfred Rohde

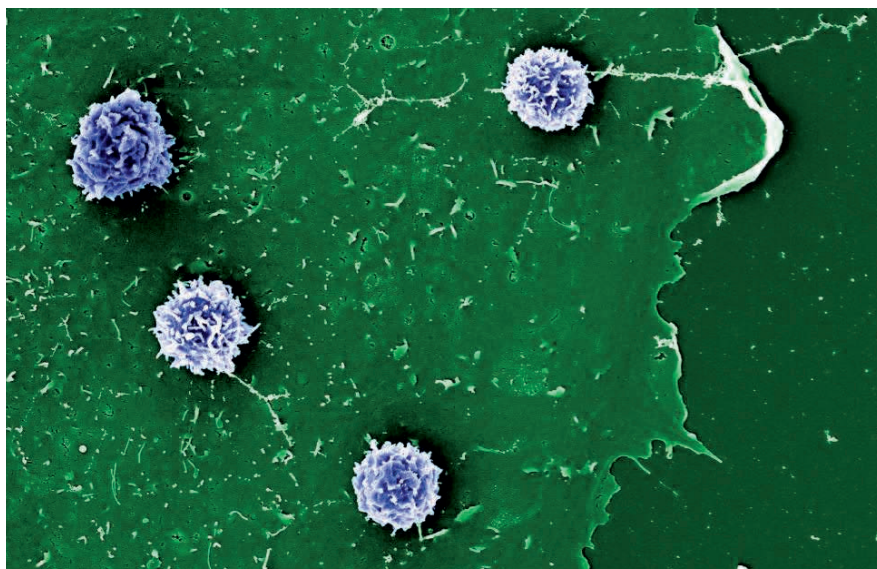

mesenchymal stem cells (MSCs) secrete factors which are able to exert immunosuppressive activities by interfering with T- and B-cell proliferation and inflammatory cytokine production. We developed the notion that expression of these factors in MSCs might be a promising tool for the therapy of autoimmune disorders.

Our hypothesis was tested in a mouse model for RA (collagen-induced arthritis in DBA/1 mice). After the onset of RA (curative treatment), native or modified MSCs expressing high levels of immunosuppressive factors were only able to exert moderate therapeutic effects. In contrast, when immunosuppressive factors were applied before onset of RA (preventive treatment), application of modified and native MSCs resulted in a therapeutic effect. Analyses of T-cell proliferation and mixed lymphocyte reactions (MLRs) showed that MSCs exert a biphasic effect. An immunostimulatory, inflammatory potential was evident at low cell numbers and the desired immunosuppressive activities only were observed with increasing cell numbers. Our investigation emphasizes the role of application time and MSCs numbers to exert anti-inflammatory and immunosuppressive properties in a chronic inflammatory disorder such as RA.

Induction of acute as well as chronic inflammation is often accompanied by an essential and massive increase of new blood and lymph vessel formation. With mouse endothelial precursors isolated from lung tissue we can induce the formation of both vessel types in mouse models if the microenvironment in the matrix is substituted with endothelial cell growth factors. However, mesenchymal stem cells (SMCs) from the bone marrow can release factors, inducing and activating endothelial cells to form new vessels in mouse models. Positive and negative regulators of blood and lymph vessels were detected by microarrays when released from MSCs into the supernatant. These factors were characterized and quantified by immunoassays. *In vivo* they produce blood vessels as well as lymphatic vessel-like structures. So far, we could not observe functional lymphatics by injection of fluorescent particles into new vascularised collagen implants.

As another anti-inflammatory strategy we are developing specific intrabodies which are able to retain the Toll-like receptors 2 and 9 (TLR2 / TLR9) in the endoplasmic reticulum (ER). We could already demonstrate that an adenovirus vector-dependent, systemic expression of an anti-TLR2 intrabody has the capacity to provide resistance to a lethal septic challenge with *Bacillus subtilis*. In another approach we could show that new intrabodies inhibit the polysialylation of the neural adhesion molecule expressed on the surface of rhabdomyosarcoma tumour cells. These intrabodies had an inhibitory effect on tumour metastasis in a xenograft tumour mouse model.



Project Members

Dr. Thomas Böldicke, Priv.-Doz. Dr. Gerhard Gross, Sandra Laggies, Dr. Virginia Seiffart, Dr. Herbert Weich, Dr. Manfred Wirth

Publications

Thiele, W., Krishnan, J., Rothley, M., Weih, D., Plaumann, D., Kuch, V., Uagliata, L., Weich, H.A., & Sleeman, J.P. (2012) VEGFR-3 is expressed on megakaryocyte precursors in the bone marrow and plays a role in megakaryopoiesis. *Blood* **120**, 1899-907.

Cudmore, M.J., Hewlett, P.W., Ahmad, S., Wang, K.-W., Cai, M., Al-Ani, B., Fujisawa, T., Ma, B., Sissaoui, S., Ramma, W., Miller, M.R., Newby, D.E., Gu, Y., Barleon, B., Weich, H.A., & Ahmed, A. (2012) The role of heterodimerization between VEGFR-1 and VEGFR-2 in the regulation of endothelial cell homeostasis. *Nature Communications* **3**, 772.

Seiffart, V., Laggies, S., & Gross, G. (2012) Mesenchymal Stem Cell-Dependent Formation and Repair of Tendon-Bone Insertions. In: *Stem Cells and Cancer Stem Cells* (Hayat, M.A., ed.), Springer-Verlag, Netherlands, Volume **3**, pp. 317-325.

Böldicke, T., Somplatzki, S., Sergeev, G., & Mueller, P.P. (2012) Functional inhibition of transitory proteins by intrabody-mediated retention in the endoplasmic reticulum. *Methods* **56**, 338-350.

European patent application EP12166489.0, May 2012: Avian cell line and its use in production of protein.



Project Leader

Dr. Werner Lindenmaier

Department of Gene Regulation and
Differentiation (RDIF)

werner.lindenmaier@helmholtz-hzi.de

Therapeutic Cellular Vaccines

Cell based immuno-therapeutics have great potential for the treatment of tumours and persistent infections. Vaccination with dendritic cells presenting the relevant antigens and adoptive transfer of antigen specific T-cells can help to overcome immune escape mechanisms in these conditions. However, such a strong induction of the immune response bears the danger of inducing pathogenic autoimmunity. These adverse events could be treated by immuno-suppressive cells like mesenchymal stromal cells (MSC). The aim of this project is to analyse the feasibility of these approaches for controlled activation and suppression of the immune response and to develop tools for the generation of the corresponding primary human cells according to regulatory requirements.

Fig. A. The osteogenic cell line MC3T3 was transduced with an adenoviral vector expressing a histone H2B-rfp-reporter protein. The red-fluorescent nuclei of the cells growing on the bars of the NH₂-modified scaffold are detected by fluorescence microscopy M. Genth, HZI and Fraunhofer IST

Fig. B. Scanning electron micrograph showing the 3D structure of a PEOT/PBT-scaffold seeded with an osteogenic cell line, bar represents 100 μ m. HZI

The influence of therapeutic vaccination and adoptive T-cell transfer was investigated in a transgenic murine model system based on the expression of influenza HA in islet cells and tumours in combination with adenovirally modified dendritic cells presenting HA and HA-specific T-cells. Protection against tumour could be achieved by vaccination and adoptive T-cell transfer. Control of autoimmunity requires further investigation. For the analysis of cell interactions, sophisticated

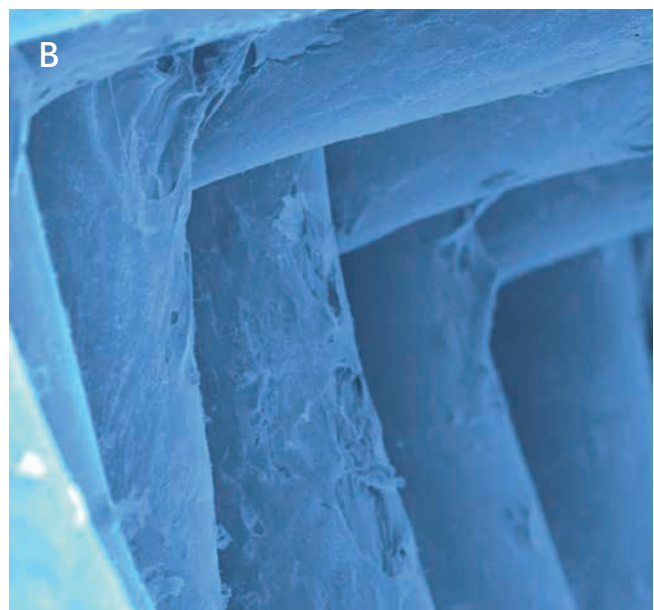
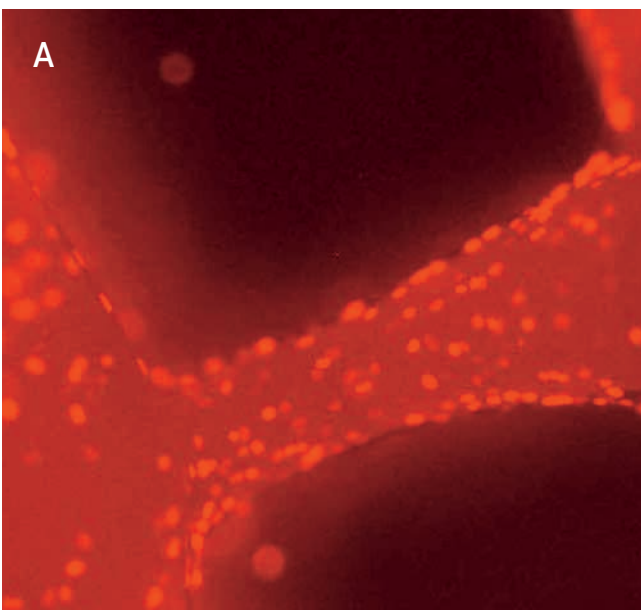

techniques for *ex vivo* and *in vivo* imaging were established covering the range from whole animals down to macromolecular structures. For this purpose luminescent nano-particles were developed for IVIS imaging (coop. C. Feldmann, KIT). Confocal laser scanning microscopy was applied for *in vivo* imaging and electron microscopy was used to visualise cell and tissue structures at high resolution (coop. M. Rohde, H. Lünsdorf, HZI).

For translation of cell therapy into clinical practice it is necessary to facilitate the generation of therapeutic primary human cells according to regulatory requirements. For this purpose we developed closed bag systems for the generation of dendritic cells. We extended this concept for adherently growing cells by specifically modifying the bag surface using dielectric barrier discharge to support growth of adherent primary human MSC (coop. M. Thomas, Fraunhofer IST, H. Garritsen, Klinikum Braunschweig).

Mesenchymal stromal cells derived from bone and from umbilical cord matrix could be expanded in the surface modified bags. MSC's grown on plasma-modified surfaces were compared extensively to conventional MSC cultures. Analysis of cell surface markers, adipogenic and osteogenic differentiation, adenoviral gene transfer efficacy and global expression profiles did not show significant differences.

Cultivation of adherent cells on plasma-modified surfaces was extended into the 3rd dimension. Surfaces of 3D-scaffolds (L. Moroni, Twente, NL) modified by plasma coating supported growth of adherent cell lines and primary MSC. The 3D structure of the cell culture will allow investigating cell behaviour in a more "natural" environment including diffusion barriers and gradients.

Analysis of the functional consequences of cell-cell and cell-surface interactions will be the focus of our research in the near future. Innovative nanoparticle based systems for the analysis of cell activation and surface modified bag cultivation systems will be developed further to support the generation of safe and functional therapeutic cells.



Project Members

Dr. Kurt E. J. Dittmar, Dr. Werner Lindenmaier, Claudia Preuß, Ellen Kuppe, Dr. Wilhelm Meyring

Publications

Müller,A.J., Kaiser,P., Dittmar,K.E., Weber,T.C., Haueter,S., Endt,K., Songhet,P., Zellweger,C., Kremer,M., Fehling,H.J., & Hardt,W.D. (2012) Salmonella Gut Invasion Involves TTSS-2-Dependent Epithelial Traversal, Basolateral Exit, and Uptake by Epithelium-Sampling Lamina Propria Phagocytes. *Cell Host and Microbe* **19** (11), 19-32.

Cruz,P.E., Cruz,H.J.S., Bárcia,R.N., Santos,M., Pohl,S., Gilljam,M., Dittmar,K., Lindenmaier,W., & Alici,E. (2012) Ex-vivo expansion of human mesenchymal stem cells. In: *The CliniBook: Clinical gene transfer* (Cohen-Haguenaer, O., ed.) Paris, pp. 111-117.

Lindenmaier,W., Macke,L., Meyring,W., Garritsen,H.S.P., Dittmar,K.E.J., Lachmann,K., & Thomas,M. (2012) Closed bag cultivation systems for the production of gene modified dendritic cells and MSC for clinical use. In: *The CliniBook: Clinical gene transfer* (Cohen-Haguenaer, O., ed.) Paris, pp. 121-127.

Lohmeyer,J.A., Liu,F., Krüger,S., Lindenmaier,W., Siemers,F., & Machens,H.G. (2011) Use of gene-modified keratinocytes and fibroblasts to enhance regeneration in a full skin defect. *Langenbeck's Archives of Surgery* **396**, 543-550.

Roming,M., Lünsdorf,H., Dittmar,K.E., & Feldmann,C. (2010) ZrO(HPO(4))(1-x)(FMN)(x): quick and easy synthesis of a nanoscale luminescent biomarker. *Angewandte Chemie International Edition* **49**, 632-637.



Project Leader

Prof. Dr. Rafael MikolajczykResearch Group Epidemiological and
Statistical Methods (ESME)

rafael.mikolajczyk@helmholtz-hzi.de

Clinical Outcomes of Infectious Diseases

One of the challenges of translational research is that interventions proven to be successful in experimental or even clinical trials might not translate into improvement of outcomes in routine care. A potential explanation is that transmission dynamics of infectious diseases in the real world differ from the experimental setting. We therefore use special epidemiological methods to address these phenomena and conduct studies in which also the natural variability of immune responses in humans is considered. The overall goal of this project is to apply epidemiological methods to improve our understanding of infection transmission, how infections lead to clinical diseases, how individual factors modify outcomes, and finally to improve individual outcomes. The project has also joint activities with the project “Epidemiological determinants for viral and bacterial infections in human populations”.

Viral shedding in respiratory infections as a component of transmission models

Viral shedding is one of the major components defining transmission dynamics of respiratory diseases. It might or might not be associated with clinical symptoms, and clinical symptoms might not be a sufficient proxy of infectiousness. Viral pathogens causing respiratory infections can have different characteristics with respect to duration of shedding. Furthermore, there can be individual differences in shedding duration and intensity. Preparatory work for studies addressing viral shedding was conducted by the Department of Epidemiology

(Krause) in collaboration with the Research Group “Molecular Epidemiology” (Pessler). A joint DFG project is being prepared, which will link determination of pathogens with symptom diaries and the measurement of the duration of viral shedding in a population based study in collaboration with the Robert Koch-Institute. Quantitative assessment of viral shedding will allow development of a novel class of mathematical models explicitly accounting for exposure parameters.

Fig. 1. Schematic model of varicella infection, immunity and vaccination effects ^{HZI}

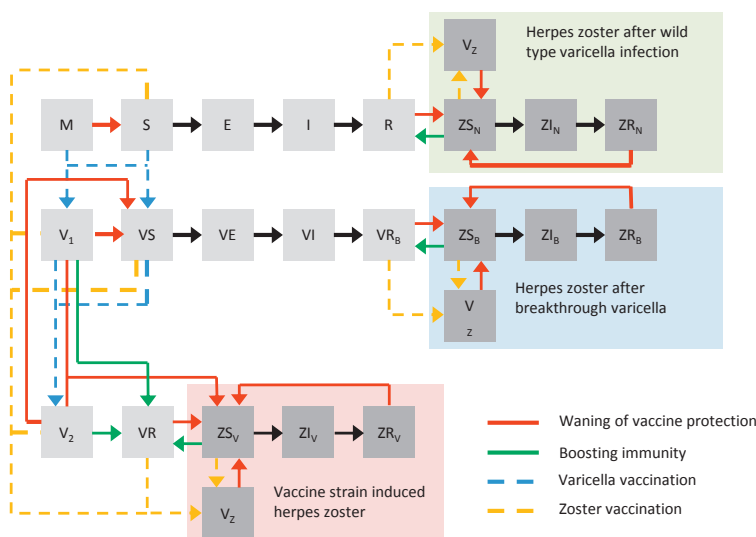

Modelling long-term effects of vaccination

Due to the dynamic nature of infections transmission, long-term effects of some vaccinations are particularly difficult to predict. For

example, a newly developed mathematical model predicted that it will take 80 years until all effects of HPV vaccines will become fully visible. The time horizon for the establishment of the effects of varicella vaccines on the herpes zoster incidence is even longer.

Development of immune response

Intra-individual development of immune response during childhood is a still unresolved mystery. We are currently establishing contacts with two birth cohorts about to start in order to supplement research questions related to infectious diseases. We are further preparing a new birth cohort dedicated solely to research on infectious diseases (Figure 2).

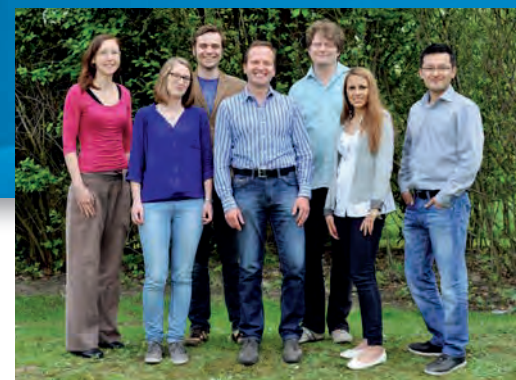
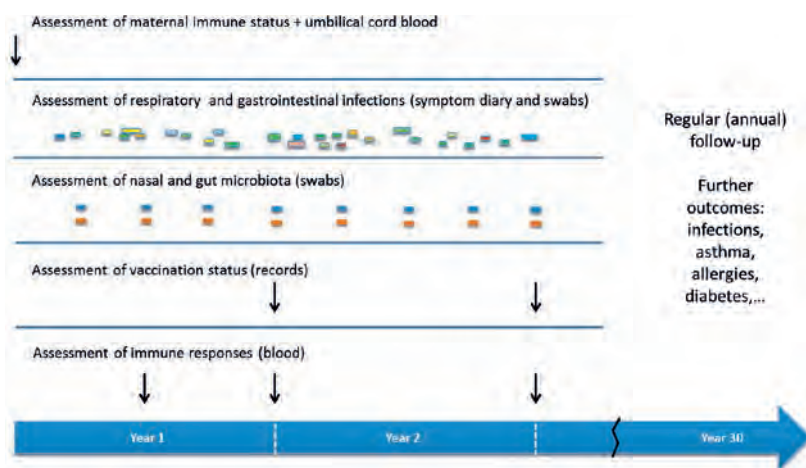

Project Members

Dr. Manas Akmatov, Dr. Stefanie Castell, Dr. Cristina Della Beffa, Johannes Horn, Dr. André Karch, Prof. Dr. Rafael Mikolajczyk, Beate Zoch

Fig. 2. Design of the planned birth cohort with focus on infections HZI

Individualized health care

Clinical outcomes are often determined not only by the available therapy but also how it is applied in routine settings. We work on the development of interventions which can effectively improve clinical practice and we designed a randomised intervention trial employing education measures to increase vaccination rates among asplenic patients in collaboration with the Integrated Research and Care Center for Sepsis in Jena.

We plan to continue the work on respiratory pathogens and link empirical estimates of viral shedding with transmission models.

We will proceed in applying mathematical models to study long-term effects of vaccination strategies.

We will deepen our focus on immune response during childhood.

We will continue our engagement in development of population level interventions to address individual patients needs.

Publications

Mikolajczyk RT, Kraut AA, Horn J, Schulze-Rath R, Garbe E. Changes in incidence of anogenital warts diagnoses after the introduction of human papillomavirus vaccination in Germany-an ecologic study. *Sex Transm Dis* 2013, 40:28-31.

Mikolajczyk RT, Zhang J, Betran AP, Souza JP, Mori R, Gulmezoglu AM, Meriardi M: A global reference for fetal-weight and birthweight percentiles. *Lancet* 2011, 377:1855-1861.

Kretzschmar M, Mikolajczyk RT. Contact profiles in eight European countries and implications for modelling the spread of airborne infectious diseases. *PLoS One* 2009;4(6):e5931.

Mossong J, Hens N, Jit M, Beutels P, Auranen K, Mikolajczyk R, Massari M, Salmaso S, Tomba GS, Wallinga J, et al: Social contacts and mixing patterns relevant to the spread of infectious diseases. *PLoS Med* 2008, 5:e74.

Kretzschmar M, Wallinga J, Teunis P, Xing S, Mikolajczyk R: Frequency of adverse events after vaccination with different vaccinia strains. *PLoS Med* 2006, 3:e272.



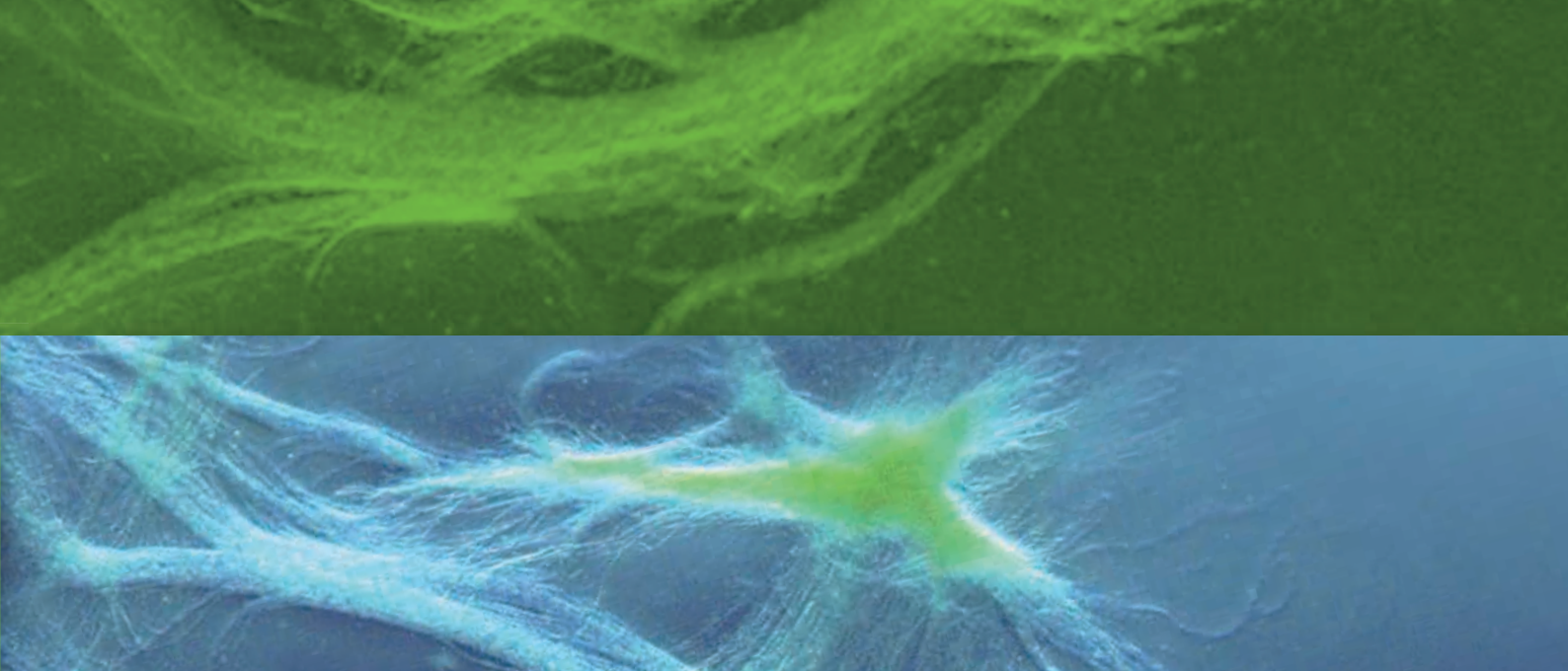

Anti-Infectives

The detailed understanding of the molecular basis of mechanisms of action and of biosynthetic processes offer unprecedented options to mine and manipulate microbial secondary metabolites. The long term objective of this Topic is to translate initial anti-infective hits into therapeutic leads for subsequent clinical evaluation. Therefore, special attention is drawn

- to natural product research at one of the worldwide leading natural products research units
- to rational drug design and the development of bioactive compounds
- to the elucidation of the relevance of respective targets for a phenotype of interest, whereas access to chemical libraries allows the identification of substances generating the phenotype of interest
- to investigate strategies to improve transport of drugs across biological barriers in particular of the gastro-intestinal tract, the skin and the lung

Photos from left to right:

Dr. Jutta Niggemann analyzing a new substance (HZI) | Diana Telkemeyer (l) and Birte Trunkwalter (r) are discussing the spread of myxobacterial fruiting bodies (HZI) | Chemical synthesis of small molecule antibacterial agents (HZI/HIPS)



Topic Speaker

Prof. Dr. Rolf Müller

Managing Director of Helmholtz-Institute for
Pharmaceutical Research Saarland (HIPS)

Department of Microbial Natural Products
(MINS)

rolf.mueller@helmholtz-hzi.de

Topic: Anti-Infectives

Historically, microbial organisms have proven to be the most prolific sources for anti-infective agents, leading to the discovery of numerous lead structures and marketed drugs. However, the number of new chemical entities that have reached clinical development and subsequently the market has substantially decreased over the past decades, despite the emerging resistance in human pathogenic bacteria against established antibiotics.

During the last decades academic research has focused on the development of holistic “omics“- technologies as the basis for innovative tools that allow the concise exploration of host-pathogen interactions (see Topics 1 and 2). Moreover, the detailed understanding of the molecular basis of mechanisms of action and of biosynthetic processes offer unprecedented options to mine and manipulate microbial secondary metabolites. The long-term objective of this Topic 3 is to translate initial anti-infective hits into therapeutic leads for subsequent clinical evaluation.

Natural product research at the HZI and HIPS

The natural products departments at the HZI/HIPS together form one of the world's leading natural products research units. They provide resources, infrastructure and know-how for the discovery, production, isolation and modification of novel anti-infective drug candidates. This work is very much related to basic and early exploratory research of the classical Hit-to-Lead evaluation process, which is indispensable in drug discovery. The HZI has successfully shown that it is possible to develop a natural compound from academia to market. Epothilone was detected in myxobacteria at the former GBF and launched into the market as a drug against advanced breast cancer by BMS in 2007 and today a variety of promising compounds are being developed in late preclinical trials.

The availability of highly diverse and well-selected strain and compound libraries is an absolute prerequisite for successful pharmaceutical screening, especially in the search for anti-infectives. The collection of gliding bacteria at the HZI constitutes an invaluable asset for the current research programme. Since 2009, strains are carefully pre-selected (exclusion of redundancies and degenerates) for a re-screening of the HZI strain collection targeted to the discovery of new anti-infectives. After growth optimization, microorganisms are subjected to fermentation and extraction, using well-established methods that have proven effective in the recent past. Various new and promising strains are being continuously isolated *de novo* from the natural environment using special

isolation methods. Connected to the bioactivity screening, these samples are characterized in parallel using a globally accepted, unique and sophisticated HPLC based de-replication methodology.

At the HZI, “classical” strain improvement methods (e.g. non-directed mutagenesis, single colony productivity screening, media optimization) are well established to prepare for scale-up of hit compounds. Skilled analytical chemists in both the HIPS and HZI are in charge of bioassay-guided HPLC fractionation and the isolation/structure elucidation of bioactive compounds. The major contributions of the natural product groups to translational research are related to the development of sustainable biotechnological and chemical processes to make the lead compounds accessible (in optimized form) to late preclinical and clinical research.

In addition to expertise in chemical derivatization and synthesis, the Topic has a strong background with biotechnology driven efforts towards structural modification and yield optimization of complex natural products, which are not easily accessible by total synthesis (e.g. large molecules exhibiting various stereocentres). For such compounds, fermentation is the preferred mode of production. Engineering technologies for microbial producers were implemented. Furthermore, systems biology studies on regulation of secondary metabolite biosynthesis in native and heterologous hosts provide information on the bottlenecks of production and enable deliberate genetic engineering of producers to increase production titers and change biosynthesis yielding optimized compounds for further development processes.

Rational drug design

For rational design and development of bioactive compounds, structure- and ligand-based optimization of lead structures, not only of their pharmacodynamics but also their ADME/T properties, is essential. The department of drug-design and optimization at the HIPS has over 20 years of experience with relevant protein targets in pertinent systems. The expertise gained, for instance,

Formation of stress granules is a strategy of infected cells to arrest protein translation and viral propagation, but diverse viruses interfere with this cellular defence reaction. Some small molecules, like the HIV inhibitor aetheramide B, also induce stress granules (white arrows) and can help to better understand the viral interference. HZI

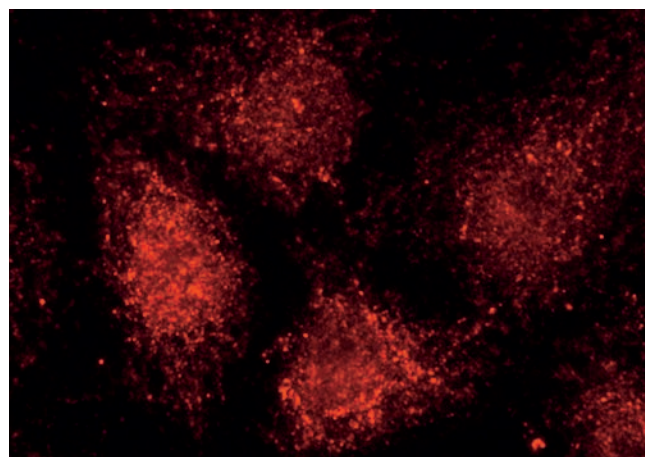
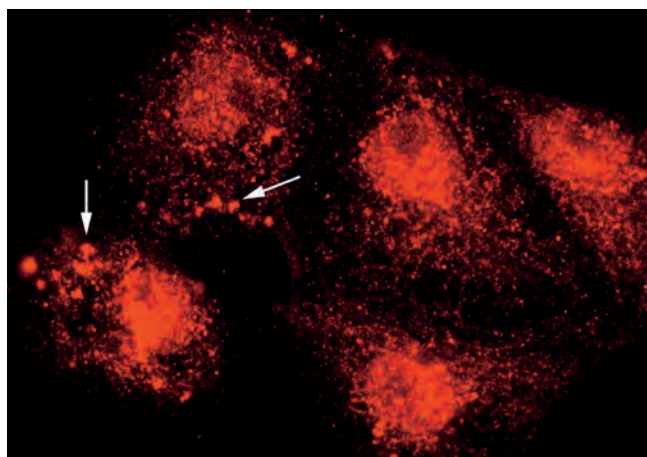

in assay development, synthesis of heterocyclic compounds and Computer-Aided Drug Design (CADD), has been applied to targets of anti-infectives to prevent the emergence of pathogens resistant to current antibiotics.

In a complementary effort, the department of medicinal chemistry at the HZI has focused on natural products syntheses. Aside from myxobacterial metabolites, marine natural products (which are hardly accessible by fermentation) are addressed. The challenge of the seen endeavours is to provide synthetic access to natural products, to improve activity and enhance pharmacological characteristics. Consequently, a variety of analogues and variants of different natural products have been synthesized, leading to improved selectivity, simplified structures and a detailed understanding of the mode of action. Moreover, natural product analogues and variants serve as molecular tools to probe their target receptors, allowing a detailed structural as well as mechanistic biochemical understanding.

Chemical biology

Low molecular weight chemical compounds are used as probes to modulate proteins and thus, modify the activity of the respective pathways or functions. The availability of known and specific inhibitors within the Topic allows the elucidation of the relevance of respective targets for a phenotype of interest, whereas access to chemical libraries allows the identification of substances generating the phenotype of interest. These small molecule probes are potential lead structures for new drugs; hence chemical biology approaches are directly linked to pharmaceutical drug development.

Epothilone B –an approved anti-cancer drug developed at the HZI. ^{HZI}

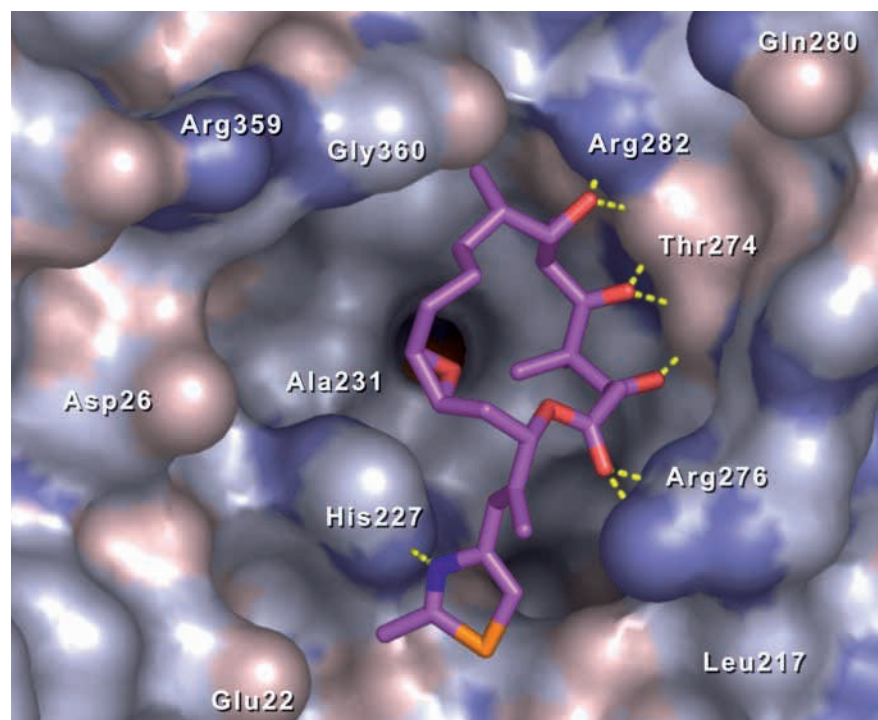

The natural compound library comprising currently approximately 400 proprietary secondary metabolites and over 2,000 extracts is complemented by a predominantly synthetic library of approximately 90,000 small molecules. It is continuously expanded by chemical and biochemical synthesis, cooperation with partners and inclusion of new isolated natural products and their derivatives. A robotics facility is established for screening campaigns mainly with cell-based assays, which were historically more related to cancer and antimicrobial activity but will be predominantly related to infection relevant processes in the future. Viral and microbial targets as well as host factors have been addressed. For in-depth analysis of the biological profile of compounds of interest, phenotypic characterization by an automated fluorescence microscope and by real-time impedance measurements has been established. Moreover, “omics” profiling, with emphasis on gene expression analysis, allows further insights into the biological effects of different compounds. Next to the experimental protocols, the respective bioinformatic tools have been developed for comprehensive analysis of profiles and comparison to reference compounds by cluster analysis.

Drug delivery

To facilitate the translation of newly discovered compounds into the clinic, the drug delivery group of the HIPS is investigating strategies to improve transport across biological barriers, in particular of the gastro-intestinal tract, the skin and the lung. Epithelial barriers may represent a serious delimiter for drug molecules to become biologically available at their target site. Established organ-specific *in vitro* models contribute to a more rapid translation of advanced drug delivery technologies into the clinic, and may at the same time represent superior alternatives to animal testing.

Taken together, the groups of Topic 3 together with their partners provide all required expertise to first identify and then move early hits in anti-infective research into lead structures in clinical research. By close interaction with Topics 1 and 2 prioritized targets can be addressed in a wide array of screens.



Project Leader

Prof. Dr. Marc Stadler

Department of Microbial Drugs (MWIS)

marc.stadler@helmholtz-hzi.de

Biodiversity Mining, Secondary Metabolomics and Applied Microbiology of Novel Anti-infective Natural Products

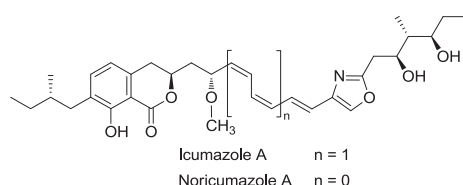
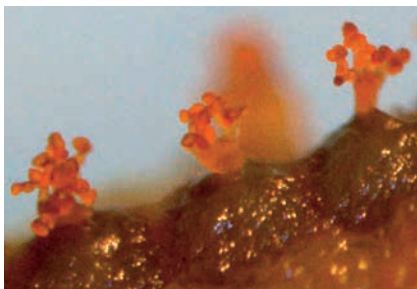

Icumazoles and Noricumazoles from Sorangium cellulosum HZI

Our research focuses on the discovery of novel anti-infective natural compounds to overcome the innovation gap in anti-infective therapy. For this purpose, the comprehensive in-house collection of myxobacteria is being revived by the Research Group “Microbial Strain Collective” (MISG / see this chapter pp 202/203) and subjected to a highly sophisticated screening and dereplication process to simplify the discovery of novel anti-infective lead candidates. In addition, the in-house strain collection and corresponding screening libraries are being substantially expanded by including fungi and unusual bacteria, such as rare actinomycetes. Data from biodiversity research (molecular phylogeny, chemical ecology, ethnopharmacology) are utilized for pre-selection of the most suitable organisms for screening. An international collaboration network and the implementation of standards from industrial research scenarios facilitate the transfer of exploratory projects into translational research including production scale-up of candidate compounds to multi-gram scale. The lead compounds are being evaluated and optimised in close collaboration with the department “Microbial Natural Products” and other researchers at the HZI and associated institutions, as well as with industrial partners.

Our major aim is to establish a sustainable pipeline of anti-infective candidate compounds for translational anti-infective drug research.

Elansolids from Chitinophaga sancti HZI

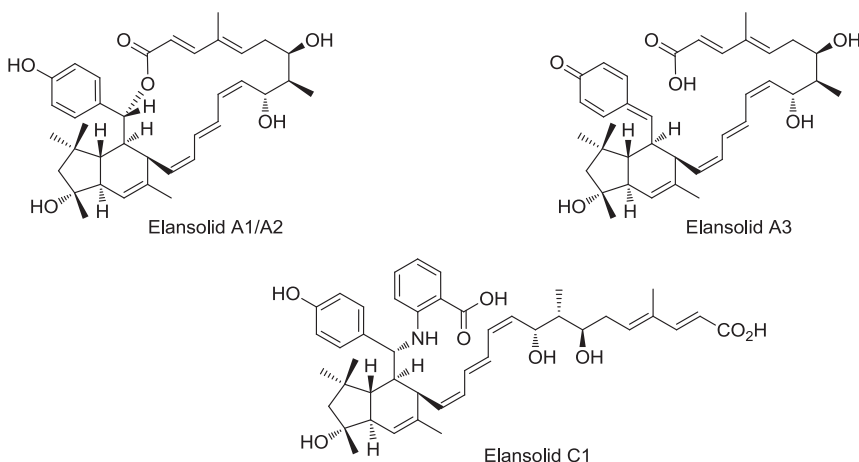

Our ongoing screening has yielded numerous unprecedented natural products with interesting biological effects, of which the proteasome inhibitors argyryns and the tubulin-depolymerizing disorazols are currently in late preclinical development as anticancer agents. One of our recent major accomplishments was the elaboration of a production process to provide disorazol Z in multi-gram scale to an industrial partner for late preclinical studies. Such laborious tasks are indispensable in translational drug research, even though they may never result in any publication in high-ranking scientific journals. The antifungal icumazols and noricumazols are additional recent examples of our interdisciplinary work on novel natural product classes, whose structure elucidation was published along with their biosynthesis and total synthesis. As exemplified by the antibacterial elansolids, our current focus on anti-infectives from rarely screened sources has already resulted in highly interesting lead compounds with novel mode-of-action. While the natural elansolids - especially the reactive quinone methide - proved too unstable in biological systems, their pharmacokinetic properties could be optimized using a precursor-directed biosynthesis approach.

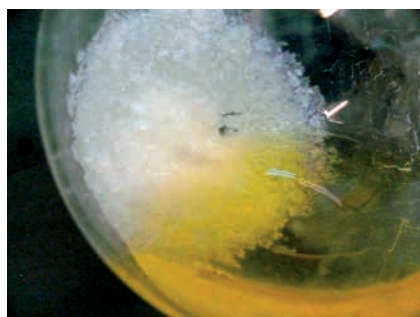

Crystallization of the anticancer lead compound Disorazol Z ^{HZI}

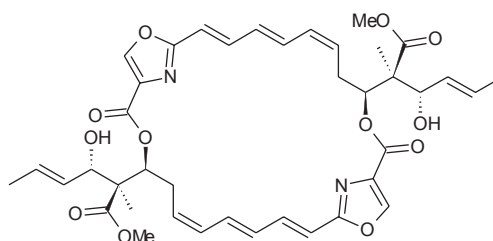

Structure of Disorazol Z ^{HZI}

As exemplified by the bottromycins, potent antibiotics from actinomycetes are also being evaluated. As with the above mentioned myxobacterial metabolites, elucidation of their biosynthesis and application of functional genomics have opened interesting new avenues to optimize the target compounds and reach a better understanding on how to improve productivity of biotechnological processes.

Following the rationale that chemical diversity of natural products parallels biodiversity, our work focuses on the isolation of novel producer organisms, their pre-selection and fermentation for anti-infective screening, the isolation and characterisation of novel secondary metabolites with interesting, selective bioactivities, and the sustainable production of these compounds for translational research.



Project Members

Steffen Bernecker, Dr. Smita Bhuyan, Sandra Halecker, Dr. Rolf Jansen, Dr. Matthias Keck, Wolfgang Kessler, Eric Kuhnert, Dr. Kathrin Mohr, Dr. Jutta Niggemann, Christian Richter, Sakshi Sood, Prof. Dr. Marc Stadler, Dr. Enge Sudarman, Dr. Frank Surup, Dr. Kathrin Wittstein, Sabrina Wolpers

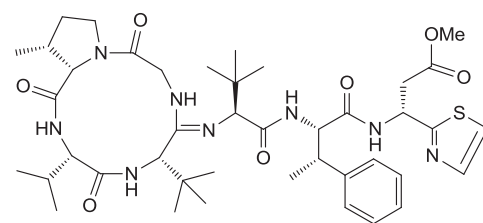

Bottromycin A2 from *Steptomyces* ^{HZI}

Publications

Barbier, J., Jansen, R., Irschik, H., Benson, S., Gerth, K., Böhlendorf, B., Höfle, G., Reichenbach, H., Wegner, J., Zeilinger, C., Kirschning, A., & Müller, R. (2012) Isolation and total synthesis of icumazoles and noricumazoles - antifungal antibiotics and cation-channel blockers from *Sorangium cellulosum*. *Angewandte Chemie - Int. Ed.* **51**, 1256-1260.

Steinmetz, H., Zander, W., Shushni, M.A.M., Jansen, R., Gerth, K., Dehn, R., Dräger, G., Kirschning, A., & Müller, R. (2012) Precursor-directed syntheses and biological evaluation of new elansolid derivatives. *ChemBioChem* **13**, 1813-1817.

Steinmetz, H., Gerth, K., Jansen, R., Dehn, R., Reinecke, S., Kirschning, A., & Müller, R. (2011) Elansolid A, a unique macrolide antibiotic from *Chitinophaga sancti* isolated as two stable atropisomers. *Angewandte Chemie - Int. Ed.* **50**, 532-536.

Bills, G.F., González-Menéndez, V., Martín, J., Platas, G., Fournier, J., Peršoh, D., & Stadler, M. (2012) *Hypoxylyon pulvicidum* sp. nov. (Ascomycota, Xylariales), a Pantropical Insecticide-Producing Endophyte. *PLoS ONE* **7**, e46687.

Huo L., Rachid S., Stadler M., Wenzel S.C., & Müller R. (2012) Synthetic biotechnology to study and engineer ribosomal bottromycin biosynthesis *Chemistry & Biology* **19**, 1278-1287.



Project Leader

Prof. Dr. Rolf W. Hartmann

Department of Drug Design and Optimization,
HIPS (DDOP)
rolf.hartmann@helmholtz-hzi.de

Development of Anti-Infectives with Novel Modes of Action

*Ligand-based drug design: Starting from the signal molecule HHQ of *P. aeruginosa*, the first PqsR antagonists were developed and optimized regarding physicochemical parameters. HZI*

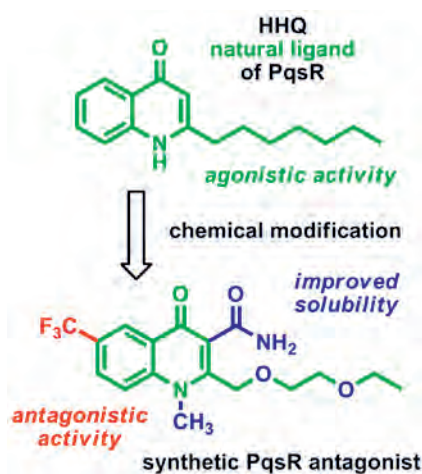

Development of anti-infectives with novel modes of action

The emergence and spread of bacteria resistant to current antibiotics are a serious and growing health problem worldwide. The major objective of our department is the rational development of novel antibacterial compounds. Here, iterative cycles of rational design and synthesis of compounds followed by biological evaluation are applied to optimize compounds to drug-like lead structures with good pharmacodynamic (PD) and pharmacokinetic (PK) properties. This is supported by computer-aided drug design approaches. Currently the research group is working on two projects: synthesis of compounds targeting either the bacterial growth or the cell-to-cell communication.

Targeting RNA polymerase (RNAP)

RNAP is an essential enzyme and an attractive validated drug target. To overcome existing resistance, we aim to develop inhibitors with alternative modes of action. In a ligand-based approach, hit compounds showing moderate activity have been discovered and rationally optimized. The inhibitors were active against bacteria such as *Multi-resistant Staphylococcus aureus (MRSA)* strains. A structure-based approach is focused on compounds targeting the “switch region” of RNAP to avoid cross-resistance with clinically used drugs. Applying a pharmacophore-based virtual screening we identified novel bioactive

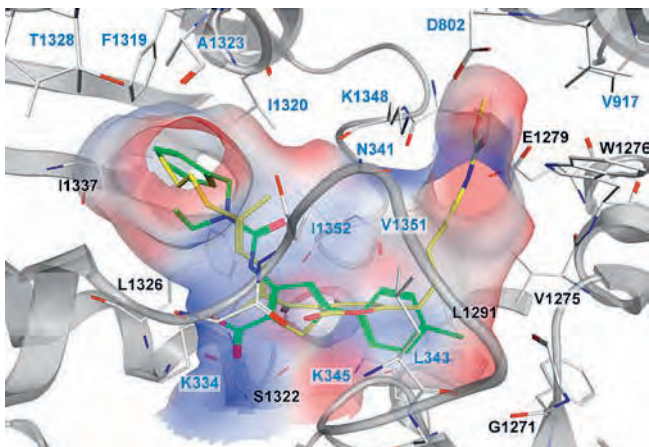

Structure-based drug design: The structural information of the binding mode of myxopyronin B (in yellow) within the RNAP, guided the optimization of a hit compound (in green). After structural modifications, potent RNAP inhibitors with antibacterial activity were obtained.

HZI

compounds, validated their binding mode and subsequently optimized their PD and PK profile. Furthermore, small peptides have been designed based on the structure of the interface of RNAP and σ , the dissociable factor responsible for transcription initiation. Thus, potent RNAP inhibitors were obtained.

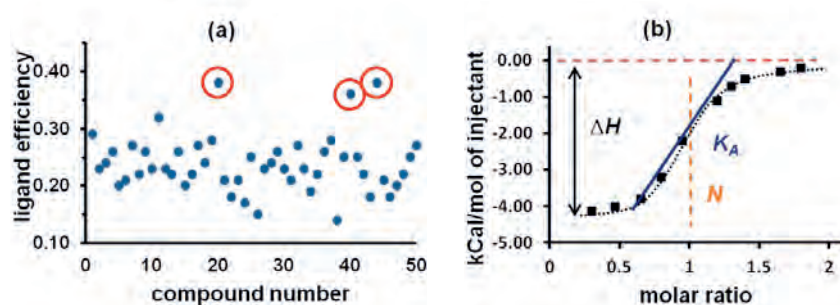

Targeting cell-to-cell communication in *Pseudomonas aeruginosa*

Another special focus is on *P. aeruginosa* that causes, among others, severe pneumonia in people suffering from cystic fibrosis. It is difficult to be eradicated especially when present in biofilm communities. Biofilm formation and virulence factor production are regulated by intercellular signal molecules. A selective blockade of this so called quorum sensing system is considered a novel therapeutic approach to limit pathogenicity and delay resistance development. Two proteins are targeted, PqsD, the enzyme for biosynthesis of signal molecules, and their receptor PqsR. In our group the first highly potent antagonists of PqsR have been developed by structural modification of the natural ligand that were further optimized regarding physicochemical properties. Furthermore, a rational design strategy and surface plasmon resonance (SPR) biosensor experiments led to the discovery of highly efficient PqsR binders with low molecular weights including antagonists. Site-directed mutagenesis combined with isothermal titration calorimetry led to insights into the binding mode. Both compound classes can effectively reduce the production of the virulence factor pyocyanin. In a ligand-based approach targeting PqsD we have designed the first inhibitors of this key enzyme. They were based on transition state analogues of the enzymatic reaction. These small molecules inhibit the production of the signal molecule PQS and reduce the biofilm formation of *P. aeruginosa*.

Using ligand- and structure-based design, as well as virtual and biophysical screening, novel RNAP inhibitors and compounds interfering with *P. aeruginosa* cell-to-cell communication were discovered and rationally optimized. They will serve as leads for further anti-infective drug development and as scientific tools to understand interbacterial processes.



Project Members

Dr. Andrea Braunschauen, Christian Brengel, Dr. Martin Empting, Martina Fruth, Dr. Matthias Groh, Prof. Dr. Rolf W. Hartmann, Dr. Jörg Haupenthal, Stefan Hinsberger, Kristina Hüsecken, Benjamin Kirsch, Cenbin Lu, Christine K. Maurer, Walid Mohammad, Dr. Matthias Negri, Jan Henning Sahner, Dr. Anke Steinbach, Michael Storz, Andreas Thomann, Michael Zender, Weixing Zhu

Biophysical Methods: An SPR based fragment screening (a) followed by the thermodynamic profiling of ligand binding using ITC titration (b) led to the discovery of novel lead compounds. HZI

Publications

Storz, M.-P., Maurer, C.-K., Zimmer, C., Wagner, N., Brengel, C., de Jong, J.-C., Lucas, S., Müsken, M., Häussler, S., Steinbach, A., & Hartmann, R.W. (2012) Validation of PqsD as an anti-biofilm target in *Pseudomonas aeruginosa* by development of small-molecule inhibitors. *Journal of the American Chemical Society* **134**, 16143-16146.

Klein, T., Henn, C., de Jong, J.-C., Zimmer, C., Kirsch, B., Maurer, C.-K., Pistorius, D., Müller, R., Steinbach, A., & Hartmann, R.W. (2012) Identification of small-molecule antagonists of the *Pseudomonas aeruginosa* transcriptional regulator PqsR: biophysically guided hit discovery and optimization. *ACS Chemical Biology* **7**, 1496-1501.

Lu, C., Kirsch, B., Zimmer, C., de Jong, J.-C., Henn, C., Maurer, C.-K., Müsken, M., Häussler, S., Steinbach, A., & Hartmann, R.W. (2012) Discovery of antagonists of PqsR, a key player in 2-alkyl-4-quinolone-dependent quorum sensing in *Pseudomonas aeruginosa*. *Chemistry & Biology* **19**, 381-390.

Hüsecken, K., Negri, M., Fruth, M., Boettcher, S., Hartmann, R.W., & Haupenthal, J. (2013) Peptide-based investigation of the *Escherichia coli* RNA polymerase $\sigma 70$: core interface as target site. *ACS Chemical Biology*, PubMed PMID: 233303640.



Project Leader

Prof. Dr. Markus Kalesse

Department of Medicinal Chemistry (MCH)

markus.kalesse@helmholtz-hzi.de

marcus.kalesse@oci.uni-hannover.de

Medicinal Chemistry of Natural Products

The quest for new antibiotics has emerged as one of the pivotal challenges in anti-infectives research. New molecules addressing specific targets are needed as well as their synthetic access and structure-activity relationship. In this context, the unique architectures of natural products provide an entry to potential new drugs. The task of medicinal chemistry is to probe whether these compounds can be further developed into pharmaceutical drugs and to probe their biological potential as well as their mode of action. Additionally, natural products are pre-optimized by evolution and have “seen” a biological target already. This background sets the starting point for natural products to potentially become drugs at an entry level with high biological activity. In contrast, compounds derived from chemical libraries need to be optimized to reach the high biological activity that natural products naturally possess. The research of the Medicinal Chemistry group is focused on providing synthetic access of natural products in order to allow their pharmacodynamic, as well as pharmacokinetic, optimization. To enable synthetic access to accomplish these goals, efficient and selective syntheses are required. Because most of the natural products isolated at the HZI are of polyketid or peptide origin, we focus our synthetic contributions to specifically allow access to these natural products. Noteworthy are vinylogous strategies, which allow constructing polyketides rapidly.

Corallopyronin und Myxopyronin HZI

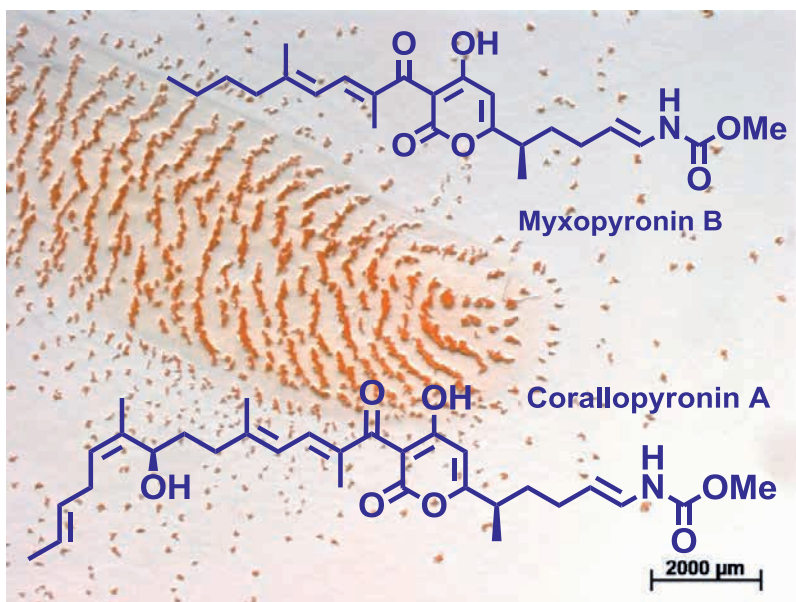



Project Members

Christina Brünjes, Nicole Bruns, Jan Geldsetzer, Prof. Dr. Markus Kalesse, Hao Lu, Dr. Evgeny Prusov, Wufeng Tang, Johanna Trenner, Anne Wodtke

The synthesis of three inhibitors of bacterial RNA-polymerases was one of our primary goals and could be accomplished recently. With the natural products corallopyronin, myxopyronin and ripostatin we can address a new binding site and potentially overcome resistance. The future direction of this research will be to produce more effective and stable analogues that unfold their activity *in vivo* and exhibit improved pharmacokinetic properties.

The argyryns were shown to address a new target in bacteria (FusA). In previous contributions, we were able to provide the synthesis of the argyryns and to establish a GMP protocol. FusA was found to be the target of the argyryns and to coincide with fusidinic acid which inhibits bacterial translation. In collaboration with Susanne Häußler (TWINCORE) we will unravel the structure-activity relationship of the argyryns for this new target and elaborate this hit to advanced stages of drug development.

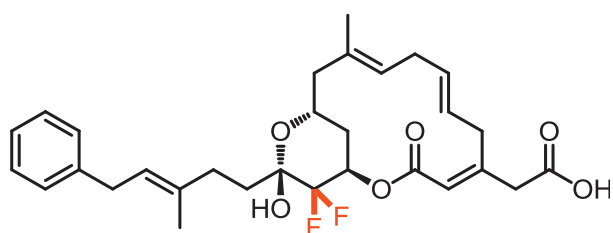

Optimized Ripostatin HZI

Haprolid is a novel natural product isolated at the HZI. It shows antiviral effects against hepatic virus C (HCV). No synthesis or SAR studies have put forward so far and we, therefore, plan to provide a stereoselective synthesis that allows for the rapid assembly of this natural compound and additionally of its isomers and analogues. Most of the work will go into the polyketide portion. Vinyllogous aldol transformations could be the way to get the desired polyketide segment.

Our future research will also incorporate technological contribution to advance polyketide synthesis to automation protocols. On these new protocols, not only the argyryns but also the vioprolides and the haprolids could be synthesized efficiently.

The Argyryns HZI

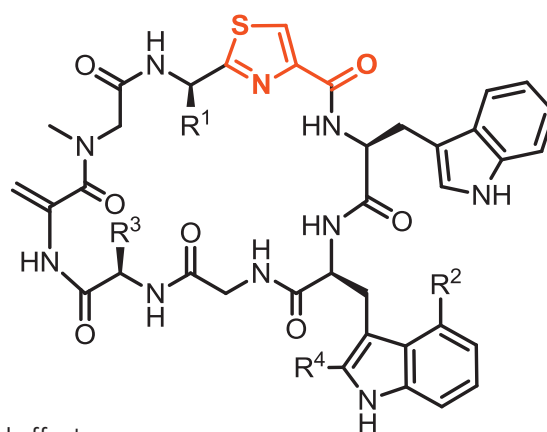

Publications

Rentsch, A., & Kalesse, M. (2012) The total synthesis of corallopyronin A and myxopyronin B *Angewandte Chemie Int. Ed.* **51**, 11381-11384.

Jahns, C., Hoffmann, T., Müller, S., Gerth, K., Waschausen, P., Höfle, G., Reichenbach, H., Kalesse, M., & Müller, R. (2012) Pellasoren: Structure Elucidation, Biosynthesis, and Total Synthesis of a Cytotoxic Secondary Metabolite from *Sorangium cellulosum* *Angewandte Chemie Int. Ed.* **51**, 5239-5243.

Schäckel, R., Hinkelmann, B., Sasse, F., & Kalesse, M. (2010) The synthesis of novel disorazoles *Angewandte Chemie Int. Ed.* **49**, 1619-1622.

Brodmann, T., Janssen, D., & Kalesse, M. (2010) Total synthesis of chivosazole F *Journal of the American Chemical Society* **132** (39), 13610-13611.

Eggert, U., Diestel, R., Sasse, F., Jansen, R., Kunze, B., Kalesse, M. (2008) Chondramide C: Synthesis, configurational assignment, and structure-activity relationship studies *Angewandte Chemie Int. Ed.* **47**, 6478-6482.



Project Leader

Prof. Dr. Rolf Müller

Department of Microbial Natural Products,
HIPS (MINS)
rolf.mueller@helmholtz-hzi.de

Metabolomics and Synthetic Biotechnology Tools for Novel and Optimised Natural Products

Natural products of microbial origin continue to be very promising sources for the development of pharmaceuticals. Natural products can exhibit diverse biological activities and modes-of-action making them useful for numerous therapeutic applications like the treatment of infections or cancer. Research in the department “Microbial Natural Products” aims at exploiting the rich biosynthetic potential of microorganisms, especially soil-dwelling myxobacteria like *Myxococcus xanthus* or *Sorangium cellulosum*, for the production of novel natural products. With a broad spectrum of techniques, including microbiological, molecular-biological, genetic, biochemical, analytical and bioengineering methods, microbial natural products are exploited for drug discovery and development approaches.

Results

Deciphering the genetic information of bacteria to obtain comprehensive insights into their theoretical metabolic capabilities currently represents the first step in natural products research. However, genome sequencing of myxobacteria is still a formidable task due to the size, GC-richness and the occurrence

Left: Red/ET recombineering mediated direct cloning and heterologous expression for genomic-based bioprospecting. HZI

Right: Role of CinF in cinnabramide bioynthesis with display of crystals of CinF. HZI

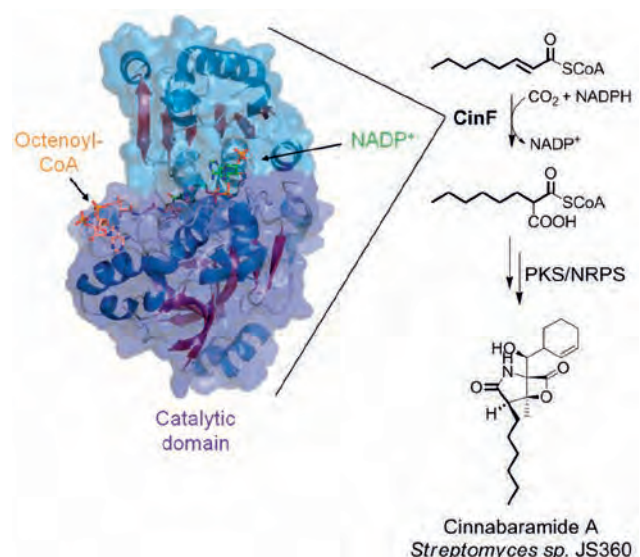
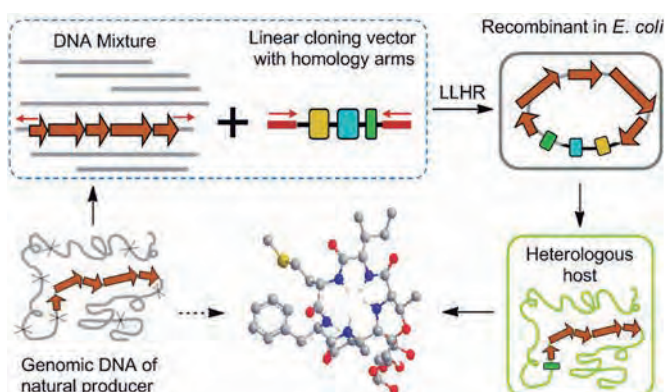



In depth metabolome analysis by straight forward analytical methods for the discovery of novel bioactive compounds.

HZI

of repeats in their DNA, just to name a few of the issues bringing complexity. In general, genome analyses have shown that the hidden biosynthetic potential of these bacteria is enormous and thus development of novel technology to harvest this treasure of hypothetical compounds is the focus of our work. Recently, significant progress has been made on two aspects: Direct cloning of large biosynthetic pathways and subsequent heterologous expression plus biostatistics based mass spectrometry analysis of secondary metabolomes to yield novel natural products.

Our results show that large secondary metabolite pathways can be cloned directly from chromosomal DNA using advanced recombineering technologies. The resulting DNA constructs can directly be engineered in *E. coli* to yield novel and altered natural products in optimized host strains. This methodology circumvents tedious and difficult preparations of large insert libraries from which target gene clusters previously had to be identified.

Moreover, we have shown that biostatistics can be used in a semi-automated fashion to analyze complex secondary metabolomes for the presence of novel natural product scaffolds, even if produced in very small amounts and if masked by other metabolites. This strategy enabled the identification of three new classes of compounds from *Myxococcus xanthus* alone.

In terms of biosynthesis and engineering perspectives we identified a novel class of enzymes involved in the formation of extender units in secondary metabolite biosynthesis. Based on the crystal structure of the crotonyl-CoA carboxylase/reductase, the stage is now set to generate enzymes with altered substrate promiscuity to supply novel extender units for polyketide biosynthesis. Introduction of such into the antifungal cinnabaramide scaffold already yielded novel derivatives of this compound class.

Our work focuses on the identification of novel natural product scaffolds, the elucidation of their structure and mode of action, as well as development of synthetic biotechnology based tools to increase yields and optimize the pharmaceutical properties of natural products aiming at translating early natural product hits into clinical application.

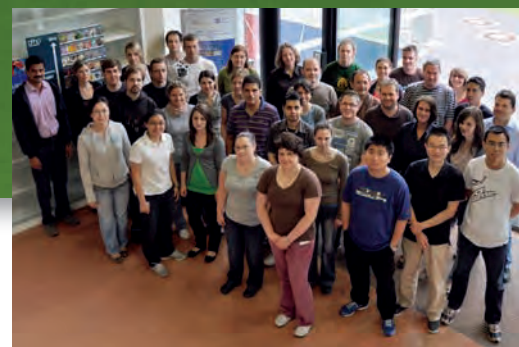

Project Members

Srikanth Duddela, Lena Etzbach, Simon Frewert, Dr. Chengzhang Fu, Dr. Ronald Garcia, Dr. Kirsten Harmrolfs, Dr. Jennifer Herrmann, Thomas Hoffmann, Stephan Hüttel, Katrin Jungmann, Angela Kling, Dr. Daniel Krug, Prof. Dr. Rolf Müller, Dr. Alberto Plaza, Dr. Kannan Ponnasamy, Dr. Ritesh Raju, Ullrich Scheid, Hilda Sucipto, Qiang Tu, Konrad Viehrig, Dr. Carsten Volz, Dr. Silke Wenzel

Publications

Quade, N., Huo, L., Rachid, S., Heinz, D.W.* & Müller, R.* (2012) Unusual carbon fixation giving rise to diverse polyketide extender units. *Nature Chemical Biology* **8**(1), 117-124.

Fu, J., Bian, X., Hu, S., Wang, H., Huang, F., Seibert, P. M., Plaza, A., Xia, L., Müller, R.* & Stewart, A. F.* & Zhang, Y.* (2012) Full-length RecE enhances linear-linear homologous recombination and facilitates direct cloning for bioprospecting. *Nature Biotechnology* **30**(5), 440-446.

Cortina, N.S., Krug, D., Plaza, A., Revermann, O. & Müller, R.* (2012) Myxoprincomide: a natural product from *Myxococcus xanthus* discovered by comprehensive analysis of the secondary metabolome. *Angewandte Chemie Int. Ed.* **51**(3), 811-816.

Katsuyama, Y., Harmrolfs, K., Pistorius, D., Li, Y. & Müller, R.* (2012) A semipinacol rearrangement directed by an enzymatic system featuring dual-function FAD-dependent monooxygenase. *Angewandte Chemie Int. Ed.* **51**(37), 9437-9440.

Jahns, C., Hoffmann, T., Müller, S., Gerth, K., Washausen, P., Höfle, G., Reichenbach, H., Kalesse, M.* & Müller, R.* (2012) Pellarsoren: structure elucidation, biosynthesis, and total synthesis of a cytotoxic secondary metabolite from *Sorangium cellulosum*. *Angewandte Chemie Int. Ed.* **51**(21), 5239-5243.



Project Leader

Dr. Florenz Sasse

Department of Chemical Biology (CBIO)

fsa@helmholtz-hzi.de

Chemical Biology of Infectious Diseases

The aim of the project is to elucidate the molecular mechanisms of infection processes by utilizing interfering small molecules. A library of 90,000 substances is available and can be screened for interesting biological activities with especially designed assays. Active compounds are used as tools to get deeper insights into infection mechanisms and can be lead structures for the development of new anti-infectives.

Novel routes of chemo-enzymatic synthesis

In order to enhance our compound library, we converted so-called privileged structures by bacterial enzymes to dihydroxylated molecules that possess a cyclic diene structure. Cyclo-addition reactions resulted in many new products that are of particular interest due to their rigid and space-filling bridged bicyclic core structures. A high percentage of these molecules showed biological activity.

Novel DUB assays

Deubiquitinating enzymes (DUBs) regulate many cellular functions linked with disease pathologies, thus representing promising therapeutic targets. We have engineered novel branched Ubiquitin Isopeptide Activity Based Probes (UIPPs) to profile ubiquitin linkage specificity of DUBs in cell extracts. The UIPPs constitute the first activity-based probes to characterize substrate specificities of DUBs in cell lysates. The technology is now applied to elucidate the role of DUBs in infection processes.

New drugs to fight cholera

The diarrheal disease cholera, which is caused by the bacterium *Vibrio cholerae*, is a severe health problem, especially in underdeveloped countries, causing more than 100,000 deaths annually. Due to the development of resistances of the bacterium against available antibiotics, treatment of heavily infected

Cycloaddition between dienes and *N*-substituted maleimides as reaction partner, including protection and deprotection of the hydroxyl groups. ^{HZI}

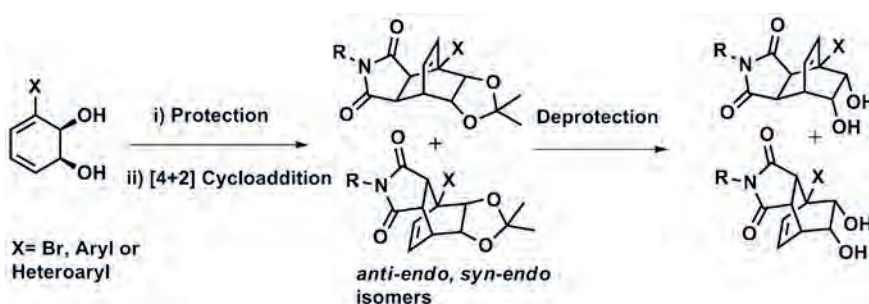

patients is increasingly difficult. Using new assay systems we screened about 30,000 substances for growth- and pathogenicity inhibitors of the bacterium. Several promising new structures were discovered. One compound inhibited the production of cholera toxin, which is causing the massive diarrhea during an infection. Another substance potently killed the bacteria by a new mode of activity. Using whole genome sequencing of mutants resistant to the drug, the target could be identified to be a histidine kinase, which is a promising new target for further drug development.

New antiviral translation inhibitors

After identifying an interesting anti-infective activity we want to find out the mode of action and the target of the active compound. Using newly developed methods, we were able to elucidate the mode of action of four new antiviral compounds. All substances inhibit the translation machinery of the host cell, but they each do it in a different way. Each compound has its specific target. These findings help to understand the interplay between translation and viral infection. A primary antiviral response of host cells to viral infection is to switch off the translation machinery, thereby globally inhibiting viral and cellular protein synthesis. Many viruses have evolved strategies for antagonizing this emergency reaction of the host. One of the discovered substances, gephyronic acid, inhibits the translation initiation by binding to eIF2 α . It is the first compound with this mode of activity. Inhibiting the eIF2 complex could be a new way of breaking the viral infection strategies.

In summary, chemical biology can provide new compounds which help to elucidate infection processes, finding new targets and lead structures. Future research will show which of the compounds can be further developed as anti-infectives.



Vibrio cholerae, the causative agent of cholera. HZI



Project Members

Ulrike Beutling, Aman Bhasin, Suryanarayana Birudukata, Dr. Michelle Fountain, Dr. Ronald Frank, Dr. Raimo Franke, Dr. Bernd Hofer, Yazh Muthukumar, Aruna Raja, Dr. Florenz Sasse, Dr. Thomas Schneider, Dr. Galina Sergeev, Dr. Werner Tegge



Docking model of gephyronic acid binding to the translational initiation factor eIF2 α .

HZI

Publications

Iphöfer, A., Kummer, A., Nimtz, M., Ritter, A., Arnold, T., Frank, R., van den Heuvel, J., Kessler, B.M., Jänsch, L., & Franke, R. (2012) Profiling ubiquitin linkage specificities of deubiquitinating enzymes with branched ubiquitin isopeptide probes. *ChemBioChem* **13**, 1416–1420.

Muthukumar, Y., Roy, M., Raja, A., Taylor, R.E., & Sasse, F. (2013) The marine polyketide myriaporone 3/4 stalls translation by targeting the elongation phase. *ChemBioChem* **14**, 1439–7633.

Diaz, N., Zhu, M., Ehrlich, G., Eggert, U., Muthukumar, Y., Sasse, F., & Kalesse, M. (2012) An improved route to (+)-tedanolide and analysis of its subtle effects controlling conformation and biological behaviour. *Chemistry* **18**, 4946–4952.

Schneider, T., Muthukumar, Y., Hinkelmann, B., Franke, R., Döring, M., Jacob, C., & Sasse, F. (2012) Deciphering intracellular targets of organochalcogen based redox catalysts. *MedChemComm* **3**, 784–787.



Project Leader

Prof. Dr. Ursula BilitewskiResearch Group Biological Systems Analysis
(BISA)

ursula.bilitewski@helmholtz-hzi.de

Identification of Molecular Targets of Anti-Infectives

The treatment of infectious diseases requires the identification of new anti-infectives with novel modes of action. Whereas classical screening relies on growth inhibition in rich media, we take the adaptability of microorganisms to current environmental conditions into account. Opportunistic pathogens, such as the yeast *Candida albicans* and the bacterium *Staphylococcus aureus*, are adapted to the presence of host cells and asymptotically colonize different body niches. These vary in pH, oxygen concentration, availability of nutrients and essential elements, or the presence of antimicrobial compounds. Thus, the environment, to which these microorganisms are usually exposed or which they experience during infection, is significantly different from the conditions, which are used during screening. Thus, pathways and functions may be relevant during infection but are not essential under classical screening conditions. Hence, we established cell culture based infection models and also mimicked selected aspects of the infectious situation *in vitro* to be able to identify respective inhibitors.

Fig. 1. Scheme showing the interaction between epithelial cells and *Candida albicans* (Ca) in the presence of neutrophils (PMN). Epithelial cells and PMNs or macrophages express on the surface similar receptors for the recognition of pathogens, e.g. toll-like receptors and C-type lectins. The basal expression level of receptors is much lower in epithelial cells than in PMNs / macrophages, but this level is significantly enhanced when pathogens are recognized which stimulates the expression and secretion of cytokines (OSM, $TNF\alpha$), chemokines (IL8) and antimicrobial peptides (AMP), such as LL37. The interaction of Ca with PMNs additionally activates signalling to the actin cytoskeleton so that pathogens are internalized by phagocytosis and killed by reactive oxygen species (ROS). HZI

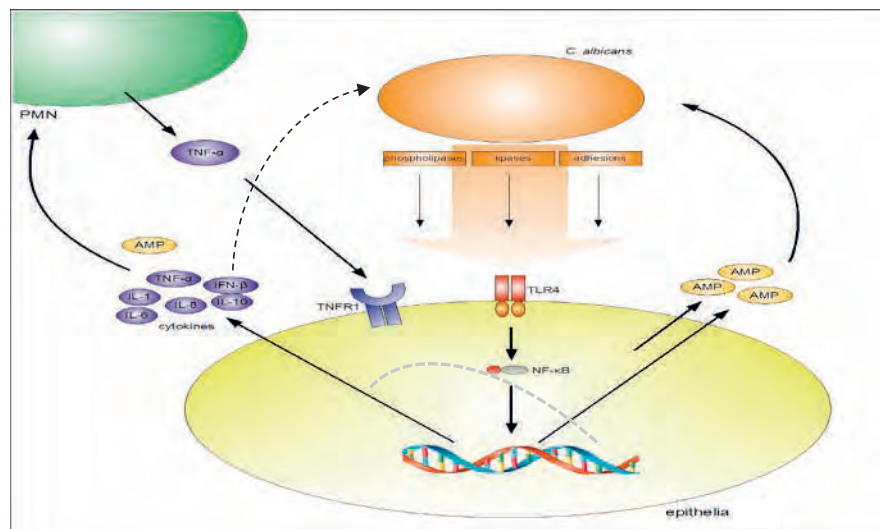

Investigations on host-pathogen interactions, the example *Candida albicans*

We used epithelial and macrophage cell lines as representatives of host cells, as they are the first cell types which interact with *C. albicans* *in vivo* during tissue colonization and after cell layer penetration. Major phenotypic responses are adhesion of pathogens on host cells and activation of immune defense reactions.

It had been shown that epithelial cells produce antimicrobial peptides, such as the cathelicidin LL37, when incubated with neutrophils (PMNs) and *C. albicans* [1] (Fig. 1). We proved antifungal properties of LL37, as it reduced growth rates of *C. albicans*, but, surprisingly, also adhesion of *C. albicans* to epithelial cells and secretion of the inflammation marker interleukin-8 by epithelial cells were enhanced. However, these effects were also influenced by the presence of serum so that further studies on the physiological relevance are required.

One of the prominent immune defense reactions of macrophages and PMNs is the clearance of pathogens by phagocytosis (Fig. 1). Previously we had found that compounds directly interfering with dynamics of the actin cytoskeleton reduced the efficiency of *C. albicans* phagocytosis [2]. Using chemical inhibitors targeting specific signal transduction cascades we identified previously unreported essential roles of the small G-protein rac1 and of glycogen synthase kinase 3 for phagocytosis. Whereas these treatments inhibited immune functions, we found that phagocytosis efficiency could be enhanced by targeting *C. albicans*. Some single gene deletion mutants had modified cell wall structures, which correlated with enhanced activation of the C-type lectin dectin-1 and enhanced phagocytosis [3]. We observed similar effects when we incubated the fungus with the isoflavone genistein or the respiratory chain inhibitor antimycin A.

To improve understanding of the underlying regulatory mechanisms we constructed a first draft of a signal transduction network model, largely based on available literature information.

- Environmental conditions mimicking the infectious situation are used during screening.
- The biological activity of chemical compounds is analyzed to discover compounds with anti-infective properties and to elucidate underlying modes of action.
- Specific chemical inhibitors contribute to the knowledge on signaling pathways, which are relevant for host-pathogen interactions.
- Network models will be constructed and further refined to allow prediction of putative drug targets.



Project Members

Prof. Dr. Ursula Bilitewski, Dr. Anna Buschart, Dr. Daniela Evers, Dr. Katja Gremmer, Mohammed El-Mowafy, Hani Kaba, Carolin Lewark

Publications

Weindl, G., Wagener, J., & Schaller, M. (2010) Epithelial cells and innate antifungal defense. *Journal of Dental Research* **89**, 666-675.

Klippel, N., & Bilitewski, U. (2007) Phagocytosis assay based on living *Candida albicans* for the detection of effects of chemicals on macrophage function. *Analytical Letters* **40**, 1400 - 1411.

Klippel, N., Cui, S., Gröbe, L., & Bilitewski, U. (2010) Deletion of the *Candida albicans* histidine kinase gene CHK1 improves recognition by phagocytes through an increased exposure of cell wall β -glucans. *Microbiology* **156**, 3432 - 3431.



Project Leader

Dr. Andriy Luzhetskyy

Junior Research Group Actinobacteria
Metabolic Engineering, HIPS (AMEG)
andriy.luzhetskyy@helmholtz-hzi.de

Actinobacteria Biosynthetic Potential: Bridging *in silico* and *in vivo*

For a long time, actinobacteria were considered as an important source of natural products, but nevertheless in the last years interest in them reduced as a consequence of a decrease of new antibiotics of actinomycetal origin introduced into the market. It was even regarded that actinomycetes are an exhausted source of natural products; however the results of sequencing data give completely opposite evidence. Genomes of actinobacteria contain huge under-explored potential to produce secondary metabolites. Most genomes contain more than twenty gene clusters responsible for production of secondary metabolites with only few being active and explored. One of the most important current tasks of streptomycetes genetics is to unveil their full potential as a source of new biologically active compounds.

Host optimization

Since most streptomycetes species are rather difficult to manipulate genetically, the easiest and the most common way to discover products encoded by “sleeping” cryptic secondary metabolite gene clusters is to express them in a heterologous host. The host should have a well-developed system for genetic manipulation for easy engineering of newly introduced biosynthetic pathways. Among all streptomycetes strains used as heterologous hosts so far, *Streptomyces albus* J1074 seems to be one of the best and most widely used. The host optimization process requires resolution of three main tasks: deletion of all secondary metabolite clusters, overall genome minimization and its metabolic engineering to meet all requirements for overproduction of target heterologous compounds.

Such tasks are almost impossible to accomplish using traditional genome engineering approaches. Here we use our “in-house” developed technology for the DNA manipulations in actinomycetes exploiting recombinogenic engineering (FLP-FRT, Cre-loxP, Dre-rox, Tn5, Himar1 and I-SceI systems).

Standard biological parts for actinobacteria

Alias, ease of engineering and tuning the introduced biosynthetic pathways does not come naturally. At the very least, controlling gene expression requires the use of proper promoters, ribosome binding sites and terminators. This is where the design and construction of standardized, modular biobrick libraries help minimize routine efforts. Applying sensitive, reliable, and easy to use reporter gene systems based on the synthetic β -glucuronidase, we have generated and characterized several libraries of synthetic promoters, ribosome binding sites and terminators for use in actinobacteria.

The genomic era in Actinobacteria research unveiled enormous hidden potential of these bacteria to produce multiple secondary metabolites with new structures and biological activities. The first step to explore the potential of these bacteria is the development of an effective toolbar of genetic manipulations with the final goal of obtaining a universal host for expression of heterologous secondary metabolites genes. This will open new horizons in studying of cryptic secondary metabolites gene clusters from different sources leading to production of novel biologically active compounds.

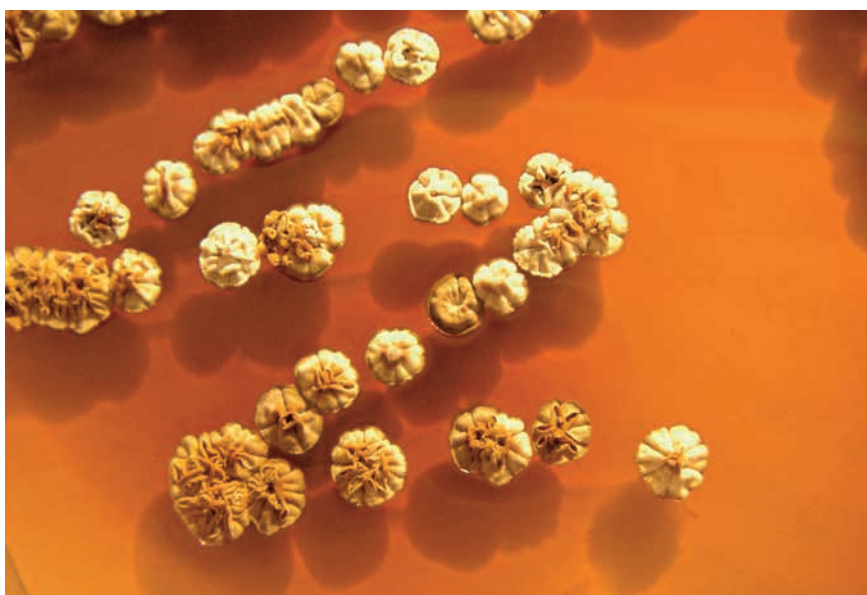

Project Members

Bohdan Bilyk, Oksana Bilyk, Dr. Elke Brötz, Dr. Lilya Horbal, Dr. Andriy Luzhetskyy, Niko Manderscheid, Dr. Maksym Myronovskiy, Dr. Yuriy Rebets, Dr. Bogdan Tokovenko

Streptomyces sp. isolated in the Nikitsky Botanical Garden of Crimea (Ukraine)

HIPS/Luzhetskyy

Publications

Herrmann, S., Siegl, T., Luzhetska, M., Petzke, L., Jilg, C., Welle, E., Erb, A., Leadlay, P.F., Bechthold, A., & Luzhetskyy, A. (2012) Site-specific recombinase strategies for engineering actinomycetes genome. *Applied and Environmental Microbiology* **78**, 1804-1812.

Bilyk, B., Weber, S., Myronovskiy, M., Bilyk, O., Petzke, L., & Luzhetskyy, A. (2012) In vivo random mutagenesis of streptomycetes using mariner-based transposon Himar1. *Applied Microbiology and Biotechnology* **97**, 351-359.

Myronovskiy, M., Welle, E., Fedorenko, V., & Luzhetskyy, A. (2011) Beta-glucuronidase as a sensitive and versatile reporter in actinomycetes. *Applied and Environmental Microbiology* **77**, 5370-5383.

Petzke, L. & Luzhetskyy, A. (2009) In vivo Tn5-based transposon mutagenesis of *Streptomyces*. *Applied Microbiology and Biotechnology* **83**, 979-986.

Fedoryshyn, M., Petzke, L., Welle, E., Bechthold, A., & Luzhetskyy, A. (2008) Marker removal from actinomycetes genome using Flp recombinase. *Gene* **419**, 43-47.



Project Leader

Prof. Dr. Claus-Michael Lehr

Department of Drug Delivery, HIPS (DDEL)
claus-michael.lehr@helmholtz-hzi.de

Nanotechnology and Cell Culture Models of Biological Barriers

Advances in molecular biotechnology and medicinal chemistry have led to the discovery of new drug candidates. However, developing these molecules into drug products requires investigating their biopharmaceutical properties as well as novel formulation strategies. Our aim is to establish new technologies to ensure the safe and effective delivery of drug candidates to the site of action, such as the site of infection or components of the immune system. Thus, our main focus is on the exploration of the biological barriers between the sites of drug administration and drug action, and on (nano)technology-based formulations to improve the delivery of biomolecules.



Rod-like nanoparticle assemblies from silica for targeting the deep lung may facilitate the treatment of pulmonary infections.

M. Schneider/cc-NanoBioNet/Deutscher Verband

Disease-relevant *in vitro* models to reduce animal experiments

The major routes for application of medicines are the oral, pulmonary and dermal route. We are investigating cell culture models to study the epithelial barriers of the lungs, the gastro-intestinal tract and the skin under controlled conditions *in vitro*. Disease-relevant *in vitro* models for infections and/or inflammation of the respective barriers allow demonstrating therapeutic efficacy of novel drug candidates via adequate bio-markers without animal experiments. Such models are useful for pre-screening or high throughput screenings of drug candidates as well as a detailed investigation of transport mechanisms in a less complex environment compared to *in vivo*.

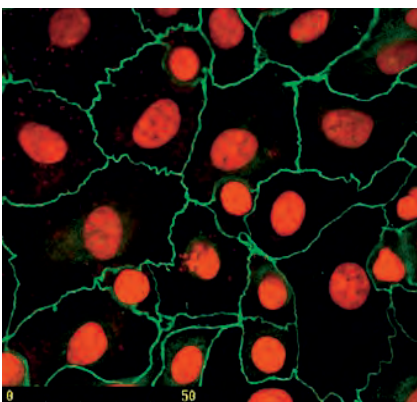

A cell culture model of the deep lung: human primary alveolar epithelial cells. (Green: distribution of tight junction protein ZO-1, red: nuclei) HZI

Our group has developed an *in vitro* co-culture model of the inflamed intestinal mucosa. The model, distinguished by two animal welfare awards of the Federal Ministry of Food, Agriculture and Consumer Protection (BMELV) and of the state of Rheinland-Pfalz, was successfully applied to test first anti-inflammatory formulations. Together with other groups at the HZI, this *in vitro* model will be applied to identify epithelial inflammation markers and to study mechanisms of bacterial adhesion and invasion of enteropathogens. Understanding and mimicking the bacterial invasion pathway will allow more effective targeting of diseased areas and increased cellular internalization of drug carriers e.g. using invasins decorated particles. Other complex disease relevant *in vitro* models, currently under investigation, are concerned with the air-blood-barrier of the lungs and pulmonary biofilms.

Carrier systems crossing biological barriers

Our second major research line focuses on innovative drug carrier systems that are capable of crossing biological barriers and thereby improving the delivery of the active molecule to the target. This is particularly relevant in the context of macromolecular biopharmaceuticals such as peptides, proteins, and RNA or DNA based drugs. The carrier systems must be safely eliminated from the body, preferably by biological degradation of its constituents. In this regard we have developed biodegradable nanoparticles for transcutaneous vaccination. Together with partners at the HZI (Department of Vaccinology, C.A. Guzmán) we could demonstrate superior immunological activity and the needle free delivery of the nano-encapsulated vaccine to the immune cells.



Project Members

Sarah Barthold, Dr. Nicole Daum, Christina Draheim, Dr. Sarah Gordon, Dr. Steffi Hansen, Marius Hittinger, Stephanie Kletting, Anna Kühn, Nicole Kuntschke, Dr. Hagar Labouta, Prof. Dr. Claus-Michael Lehr, Dr. Brigitta Loretz, Nico Mell, Babak Mostaghaci, René Rietscher, Sandra Sapich, Dr. Carolin Thiele, Hiroe Yamada

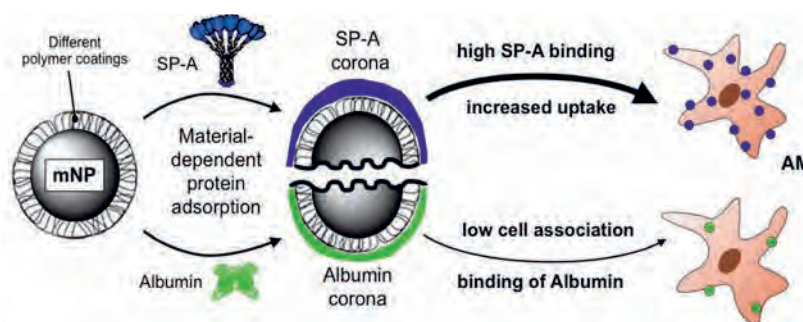
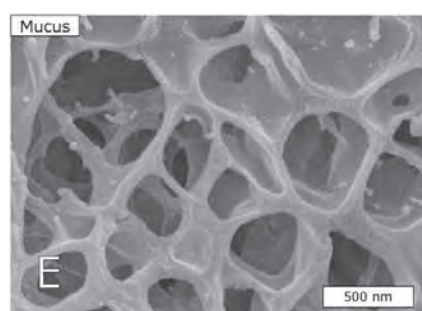

Left: Bronchial Mucus builds up a non-cellular barrier towards drug delivery. Right: The interaction between mucus surfactant proteins and nanoparticulate drug carriers may change the carrier properties and thus influence drug delivery. HZI

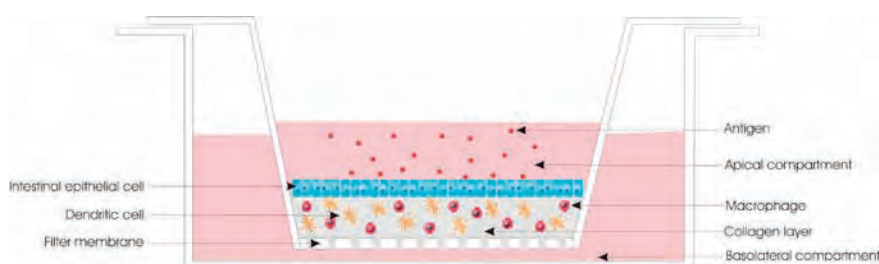

A 3D cell culture model of the inflamed intestinal epithelium to evaluate formulations of anti-inflammatory drugs. HZI

In summary we are interested in a deeper understanding of the function of biological barriers in healthy and diseased state as well as in their interaction with (nano) particulate drug carriers. Furthermore, such advanced formulation technologies may salvage molecules with promising anti-infective activity but difficult biopharmaceutical profile where classical approaches from medicinal chemistry and bioengineering fail and thus decrease the drop-out rate of drug candidates.

Publications

- Mittal, A., Raber, A.S., Ebensen, T., Schulze, K., Weissmann, S., Guzmán, C.A., Schaefer, U.F., Lehr, C.-M., & Hansen, S. (2013) Non-invasive delivery of nanoparticles to hair follicles - a perspective for transcutaneous immunization. *Vaccine* **31**(2013), 3442-3451
- Kirch, J., Schneider, A., Abou, B., Hopf, A., Schaefer, U.F., Schneider, M., Schall, C., Wagner, C., & Lehr, C.-M. (2012) Optical tweezers reveal relationship between microstructure and nanoparticle penetration of pulmonary mucus. *Proceedings of the National Academy of Sciences of the United States of America* **109**(45), 18355-18360.
- Ruge, C.A., Schaefer, U.F., Herrmann, J., Kirch, J., Canadas, O., Echaide, M., Perez-Gil, J., Casals, C., Mueller, R., & Lehr, C.-M. (2012) The interplay of lung surfactant proteins and lipids assimilates the macrophage clearance of nanoparticles. *PLoS ONE* **7**(7), e40775.
- Schmidt, C., Lautenschlaeger, C., Collnot, E.M., Schumann, M., Bojarski, C., Schulzke, J.D., Lehr, C.-M., Stallmach, A. (2013) Nano- and microscaled particles for drug targeting to inflamed intestinal mucosa-A first in vivo study in human patients. *Journal of controlled release* **165**(2), 139-145.
- Schaefer, J., Schulze, C., Marxer, E.E.J., Schaefer, U.F., Wohlleben, W., Bakowsky, U., Lehr, C.-M. (2012) Atomic force microscopy and analytical ultracentrifugation for probing nanomaterial protein interactions. *ACS Nano* **6** (6), 4603-4614.



Project Leader

Priv.-Doz. Dr. Joachim Wink

Research Group Microbial Strain
Collection (MISG)
joachim.wink@helmholtz-hzi.de

Microbial Strain Collection

■ Myxobacteria from the GBF
■ Myxobacteria New Isolates (HIPS)
■ Actinomycetales Reference Strains
■ Actinomycetales New Isolates (HIPS)

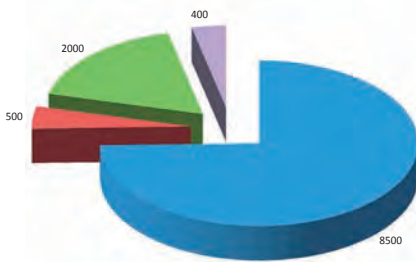

Strains in our collection. HZI

The microbial strain collection of the HZI has its focus on Myxobacteria and other uncommon microorganisms, especially rare Actinobacteria. Our myxobacterial strain collection comprises approximately 8500 strains from the GBF collection. In the course of an antimicrobial discovery programme, the re-activation of nearly 2000 strains of a diverse, in terms of species and global sampling sites, basic collection has already been accomplished. Myxobacterial crude extracts are prepared in standardized procedures and undergo routine biological and chemical screening. In addition, we have about 500 new isolates of Myxobacteria, isolated from various resources. Many of these isolates represent unexplored genera and families in unexpected novel myxobacterial groups. Also the collection includes about 2000 reference strains of the class Actinobacteria and 400 new isolates of uncommon genera.

1. Myxobacteria and Actinobacteria - Novel isolates as source for new antibiotics

During the last decades many pharmaceutical companies have terminated their antibiotic research activities and the general assumption that microorganisms exhibit only minor unexploited potential for antibiotic discovery became entrenched. However, at the same time more and more of the so called “neglected” genera which were previously difficult to cultivate have become accessible by the use of new techniques enabling the screening and detection of their secondary metabolite profiles. Also by use of new and uncommon isolation methods, new species can be extracted from biological samples. Despite the tremendous developments originating from genomics, isolation of new genera and subsequent screening for the production of new metabolites is still the most successful way of finding novel antibiotic scaffolds that often exhibit new modes of action.

2. Induction of „silent“ genes

Although the isolation of novel species and families significantly increases the chances of the discovery of novel chemical entities, most of the already known and well described species also harbor a huge “hidden” biosynthetic potential in their genome. For the induction or enhancement of the production of these potential metabolites, a wide spectrum of techniques has successfully been used. Beside large media composition changes, single chemical inductors like DMSO are found to act as production enhancers and rare earth elements

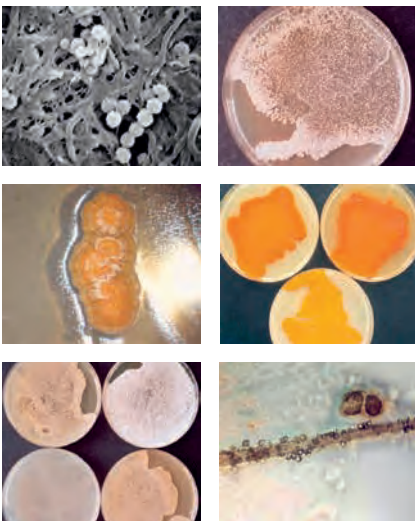

Some examples of uncommon actinomyces Wink / Compendium of Actinobacteria;

<http://www.dsmz.de/bacterial-diversity/compendium-of-actinobacteria.html>

activate secondary metabolite-biosynthetic gene clusters in *Streptomyces* species. There is a wide range of external cues and stress factors that influence secondary metabolite production. Also, microbial inducers play an important role; many different approaches have shown the influence of living or dead cells on potential metabolite producing microorganisms. Chemical signals from the induced metabolite producing strain towards the stimulator strain have been observed. Such signalling factors are widespread in microbial communication.

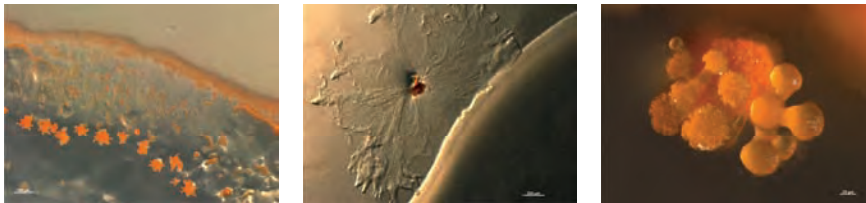

3. Extract Screening

For the extract screening the production of myxobacterial extracts by use of our standardized process has to be continued and the use of incubation systems in microtiter format for Myxobacteria and Actinomycetes will be established.

4. The strain collection database „Myxobase“

With Myxobase, we have an in-house developed database for the microbiological and compound data of our strains. Especially the microbial part including cultivation and the compiling of characterization data will be extended and the data of Actinobacteria will be included.

Biodiversity guided expansion of existing microbial strain collections is seen as one of the most promising ways forward for generating novel antibiotic scaffolds. Coupled to more sophisticated screening efforts for bioactivity and more comprehensive analysis of each species, bacterial secondary metabolites offer great potential for the discovery and development of leads in anti-infective research. Although intensively studied, the actinomycetes, and the much less analyzed myxobacteria, are far from being exhausted as resources of novel chemistry and compounds exhibiting new modes of action. In contrast, recent research has shown their enormous potential for future discoveries.



Project Members

Wiebke Landwehr, Heinrich Steinmetz,
Priv.-Doz. Dr. Joachim Wink

Three examples of myxobacteria shown with their fruiting bodies on the agar surface belonging to the families where as yet only one species is known or to new families which await valid description. HZI

Publications

Gerth, K., Pradella, S., Perlova, O., Beyer, S., & Müller, R. (2003) Myxobacteria: proficient producers of novel natural products with various biological activities – past and future biotechnological aspects with the focus on the genus *Sorangium*. *Journal of Biotechnology* **106**, 233-253.

Wink, J., Kroppenstedt, R.M., Ganguli, B.N., Nadkarni, S.R., Schumann, P., Seibert, G., & Stackebrandt, E. (2003) Three New Antibiotic Producing Species of the Genus *Amycolatopsis*, *Amycolatopsis balhimycina* sp. nov., *A. tolypomycina* sp. nov., *A. vancoresmycina* sp. nov. and Description of *Amycolatopsis keratiniphila* subsp. *keratiniphila* subsp. nov. and *A. keratiniphila* subsp. *nogabecina* subsp. nov.. *Systematic and Applied Microbiology* **26**, 38-46.

Wink, J. (2003) Polyphasic Taxonomy and Antibiotic Formation in some Closely Related Genera of the Family Pseudonocardaceae. In: Recent Research Developments in Antibiotics (Pandalai, S.G., ed.), Transworld Research Network, Kerala India, pp. 97-140

Wink, J. (2011) How can Actinomycetes Taxonomy and Natural Product Research work together? *Microbiology Australia* **32**, 81-85.

Müller, R. & Wink, J. (2013) Future Potential for Anti-Infectives from Bacteria – How to exploit Biodiversity and Genomic Potential. *International Journal of Medical Microbiology*, submitted.

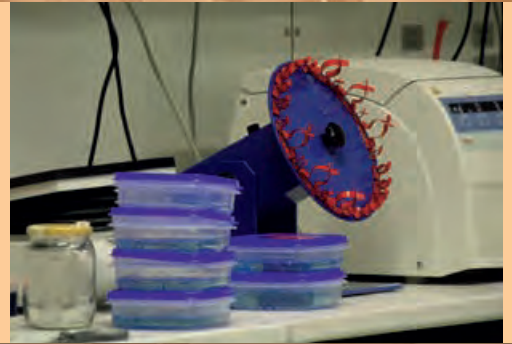
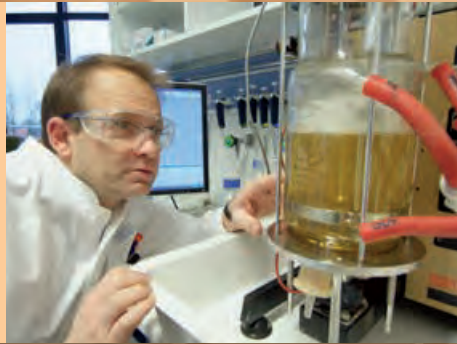

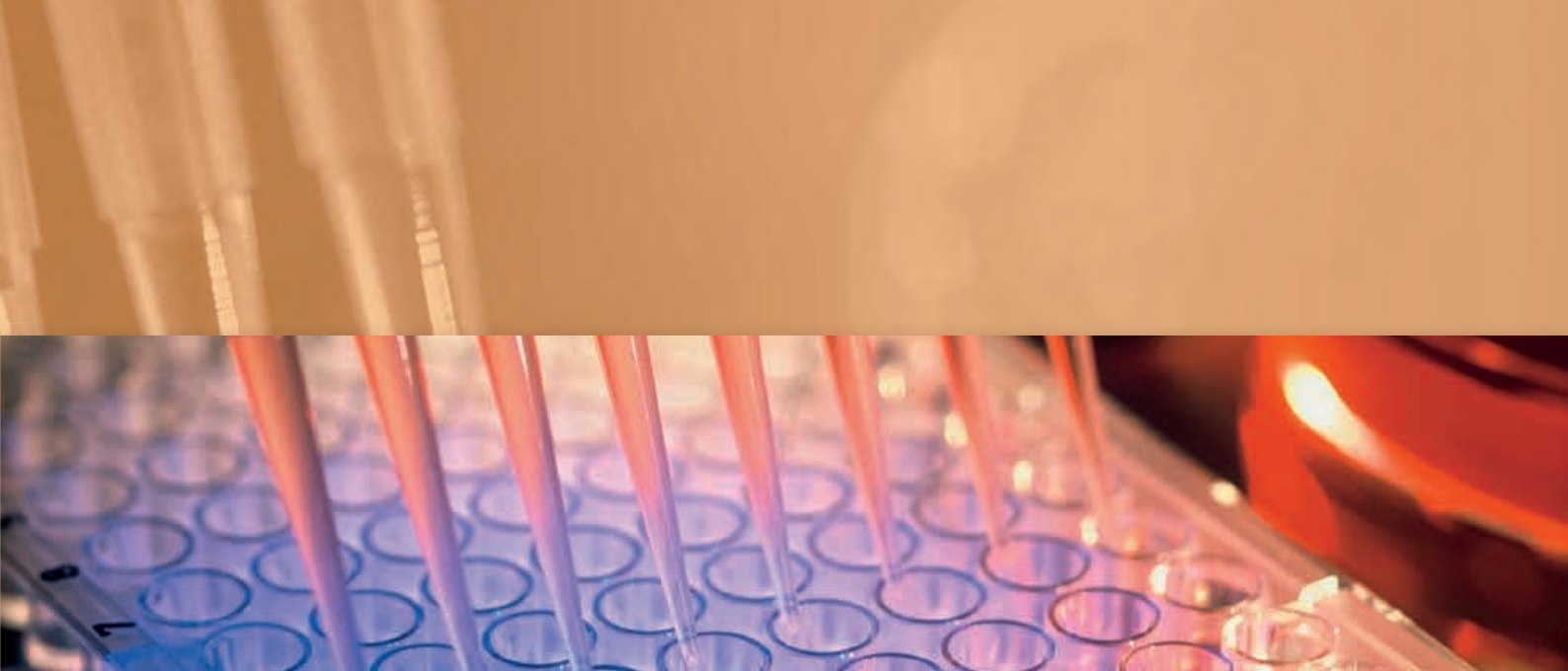

Platforms

A number of platform technologies essential for research and development carried out at the Helmholtz Centre for Infection Research are made available to the scientific projects as centralised facilities. In the context of national and international research programmes, these platforms provide services not only to internal projects, but also to scientific collaborators from other Helmholtz research centres, universities, other public research institutes, and industry. On the following pages the most important platforms are described in detail.

Photos from left to right:
The Mouse House, animal facility – awarded for its architecture (HZI/Schughart) |
Dr. Joop van den Heuvel controlling a fermentation process (HZI) |
Imagines from a laboratory (HZI/Bischof)



Head

Dr. Hermann Riedesel

Central Animal Facility (TEE)
hri07@helmholtz-hzi.de

Central Animal Facility

The Central Animal Facility provides state of the art laboratory animal care and services for the scientific needs of the HZI and TWINCORE in compliance with the German and European animal welfare guidelines and regulations. All staff members are committed to maintain the best hygienic quality standards and to ensure that all animal care and use procedures are conducted within the highest scientific, humane and ethical principles, which are essential prerequisites for biomedical research.

At the HZI Braunschweig, the TEE facilities consist of 21 animal rooms, 6 animal labs and 10 adjacent procedure rooms with a total capacity of 15,000 cages, which equals 37,500 mice. These rooms are located in four buildings (K, T1, T2 and D annex), which comprise of a 961 m² animal holding area. Almost all animals housed are laboratory mice complemented by a few rats and hamsters. All animals are kept in individually ventilated cage (IVC) systems in seven holding units of five different hygiene and three biosafety levels. Five units are constructed as a complete specific-pathogen-free (SPF)-barrier. Two units are registered as animal biosafety level 2 (ABSL2) and one as ABSL3 facility for infection experiments. The average daily animal census is currently about 32,000 mice consisting of 584 different strains and genetically engineered lines. The health status, which is monitored on a quarterly basis by a dirty bedding sentinel programme, fully complies with the FELASA recommendations. Staff includes two lab animal veterinarians, one animal welfare expert, 2.5 organization staff (1 facility manager, 1 animal welfare assistant, 0.5 secretary), 4.75 lab technicians for the histopathological and the biotechnical lab, 21 animal caretakers and 7.25 cage washing personnel.

A mouse from the Central Animal Facility
HZI



The satellite mouse facility at TWINCORE in Hannover consists of four animal rooms and two procedure rooms with floor area of 96.5 m² and a cage capacity of 2,300 IVC cages with ABSL 1, 2 and 3** capabilities. The core breeding of all TWINCORE lines is performed at the HZI, so that the TWINCORE facility will be mainly used for expansion breeding and experimental holding. In this way, mice kept at TWINCORE exhibit the same hygienic status as at the HZI. 4.5 animal technicians are working at the TWINCORE facility offering basic animal care, breeding and colony management and experimental assistance. All the other services are performed by the HZI animal facility.

The following services are offered by TEE:

Animal welfare services | Basic animal care | Breeding services and colony management (according to the order of the scientists) | Assistance with experimental procedures (compound administration, sampling of blood and tissue, immunization) | Organization of national and international mouse shipments | Training programme for animal care technicians (6 apprentices) | Consultation and training in laboratory animal science (basic and FELASA B courses) | Animal procurement | Quarantine and re-derivation of imported lines | *In vitro* fertilization for rescue, speed expansion and re-derivation of mouse lines | Embryo-cryopreservation of mouse lines and banking of germplasm | Health monitoring | Histopathological services

Table 1 summarizes the TEE services over the past three years, which are steadily increasing. By the end of 2012, all breeding, holding and experimental units of the Central Animal Facility at the HZI and TWINCORE have been fully in use. Thus, the enlarged and improved animal facilities will be able to offer several new choices for scientific users like increased cage capacity, more ABSL 2 space, a better hygienic zoning by strict separation of breeding and experimental units and the possibility to perform preliminary studies with animals from external sources.

Service	2010	2011	2012
Cage census HZI	5500	6350	7250
Cage census TCOR	600	1400	1150
Mouse lines	450	473	584
Mouse shipments national	65	67	88
Shipments international	25	31	42
Active animal protocols	59	63	107
Mouse lines embryo transferred	50	72	67
IVF on mouse lines	25	20	26
Mouse lines cryoperserved	16	12	47
Training courses	0	6	22

To fulfil the steadily increasing scientific needs of the HZI the following goals will be achieved in the animal facility in 2013:

- Extension and continuous improvement of all TEE services offered
- Increased cage capacity and better utilization of TEE
- Start of the ABSL3 unit in the first half of 2013
- Construction and operation of a germfree unit for colonization experiments
- Extended animal welfare services and implementation of the EU directive 2010/63 without negatively affecting biomedical research at the HZI and TWINCORE



The crew of the Central Animal Facility

HZI / Hallbauer & Fioretti



Head

Dr. Joop van den Heuvel

Research Group Recombinant Protein
Expression (RPEX/PSPF)
joop.vandenheuvel@helmholtz-hzi.de

Helmholtz Protein Sample Production Facility

The PSPF is dedicated to develop and provide infrastructure for the production of biomacromolecules for structural biology research. The decentralized facility is shared since 2007 between the Helmholtz Centre for Infection Research (HZI) in Braunschweig and the Max-Delbrück-Center (MDC) in Berlin.

The PSPF facility in Braunschweig is providing the Department of Molecular Structural Biology with high quality protein samples for structural and biochemical studies. Currently 50% of the capacity of the unit is used for internal HZI projects. Projects from other research institutions as well as universities can be applied for.

Additionally, the PSPF develops new and fast strategies to overcome protein sample production limitations for complex targets like mammalian receptor proteins and multi-protein complexes using mammalian protein production systems.

The PSPF platform is a partner in the EU-Programme Instruct (Integrated structural biology infrastructure for Europe) as a centre for mammalian protein production. Since April 2012 Instruct offers grants for training internships, practical courses and access to the Instruct infrastructure for peer-reviewed applications. Two access applications have been allocated to the HZI. Additionally, support for the organization of an international course in “mammalian protein expression in animal cell culture” in 2013 has been assigned to the PSPF.

A further successful international cooperation of the PSPF is within the ComplexInc EU-FP7 Health 2011.1.1.1 project: “New technologies and production tools for complex protein biologics”.

Recombinant protein expression research group (RPEX)

The PSPF is an integral part of the RPEX research group, which is focusing on the development of a new and fast multi-Host strategy. The mHost XS system allows fast screening of many constructs in parallel to identify the optimal expressible construct using the licensed HEK 293 transient transfection system. Thereafter, a direct transfer to our in-house RMCE master cell lines for CHO or insect expression is possible. Additionally, the multiprotein Baculoviral Expression Vector System can be used without additional recloning. This system has

been evaluated for intracellular expression using fluorescent proteins (EGFP, mCherry and tdTomato) as well as secretory proteins like TLR2 and scFv-FC recombinant antibodies. Some of the producing cell lines have been developed to produce protein for cooperation partners within the HZI (DC-LAMP, LAMP-2, hsE2, TLR1, TLR5). The expression level varies between 0.5 - 3 mg/L and can be easily and reproducibly scaled up to 10-100 L. In cooperation with our project partner, the protein complexes are prepared for crystallographic analysis.

As a powerful tool for rapid expression of recombinant proteins using mammalian cells, the transient transfection of HEK293 EBNA1 cells has been established and further optimised with regard to high level protein expression. In this process there is no need for media exchange between the phases of cell transfection and recombinant protein production thus making it highly convenient for both small-scale production in shaker flasks as well as up scaling in bioreactor systems. While including a specific strategy of consecutive feeding steps of nutrients and productivity enhancers during the protein production phase it was possible to obtain recombinant antibody product concentrations well in excess of 650 mg L⁻¹.

Intrabody Facility

A new intrabody facility has been established at the beginning of 2013. The aim of the facility is the *in-vitro* knockdown of infection relevant proteins in cell lines as well as in transgenic intrabody mice. We will focus on ER intrabodies, which mediates functional inhibition of transitory proteins passing through the ER (for example cell surface and intracellular receptors, Golgi located enzymes) by preventing them to reach their site of action. The new facility is working together with the recombinant antibody selection group of Prof. S. Dübel at the TU Braunschweig and the transgenic mouse facility of Dr. D. Wirth. This cooperation leads to a unique pipeline comprising recombinant antibody selection technology, ER intrabody generation and transgenic intrabody mice.

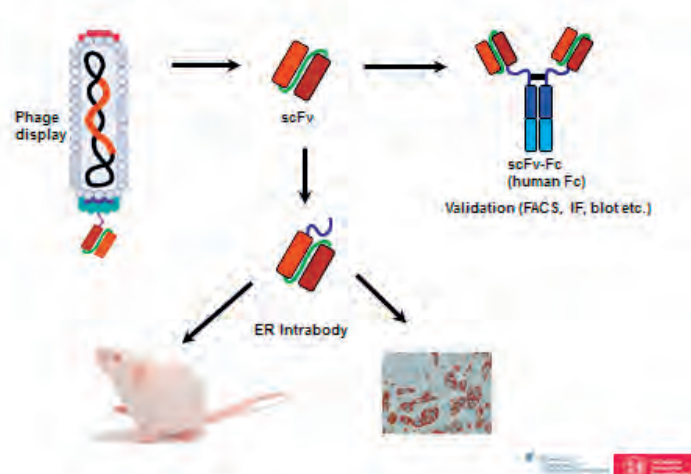

Recombinant Antibody and intrabody development. HZI



Scientific Collaborators

Bahar Baser, Maren Bleckmann, Dr. Thomas Böldicke, Dr. Konrad Büssow, Thomas Heidler, Dr. Volker Jäger, Katharina Karste, Dr. Steffen Meyer, Christian Schinkowski



HEK293-6E cell pellets 168h post transfection with pFlpBtM-II-mCherry, tdTomato & -eGFP (left to right). HZI

Publications

De Groot, J.C., Weidner, C., Krausze, J., Kasamoto, K., Schroeder, F.C., Sauer, S., & Büssow K. (2013) Structural Characterization of amorfrutins bound to the peroxisome proliferator-activated receptor. *Journal of Medicinal Chemistry* **56**, 1535-1543.

Kugler, J., Schmelz, S., Gentsch, J., Haid, S., Pollmann, E., Van Den Heuvel, J., Franke, R., Pietschmann, T., Heinz, D.W., & Collins, J. (2012) High affinity peptide inhibitors of the hepatitis C virus NS3-4A protease refractory to common resistant mutants. *Journal of Biological Chemistry* **287**(46), 39224-39232.

Wilke, S., Krausze, J., & Büssow, K. (2012) Crystal structure of the conserved domain of the DC lysosomal associated membrane protein: Implications for the lysosomal glycoalkal. *BMC Biology* **10**, 62.

Weidner, C., De Groot, J.C., Prasad, A., Freiwald, A., Quedenau, C., Kliem, M., Witzke, A., Kodelja, V., Han, C.-T., Giegold, S., Baumann, M., Klebl, B., Siems, K., Muller-Kuhrt, L., Schürmann, A., Schüler, R., Pfeiffer, A.F.H., Schroeder, F.C., Büssow, K., & Sauer, S. (2012) Amorfrutins are potent antidiabetic dietary natural products. *Proceedings of the National Academy of Sciences* **109**(19), 7257-7262.

Böldicke, T., Somplatzki, S., Sergeev, G., & Mueller, P.P. (2012) Functional inhibition of transitory proteins by intrabody-mediated retention in the endoplasmic reticulum. *Methods* **56**, 338-350.



Head

Dr. Robert GeffersResearch Group Genome Analytics (GMAK)
rog@helmholtz-hzi.de

Genome Analytics

In November 2011 the Gene Expression platform was extended by modern high-throughput next generation sequencing systems (HiSeq2500, MiSeq) as well as by standard sequencing systems for custom DNA sequencing (ABI 3730xl). Together with well-established and proven concepts of microarray technology, the newly founded technology group GMAK (Genome Analytics) provides state of the art technology for applications in the field of genomics, epigenomics and transcriptomics.

Genomics:

Copy number variation (CNV) is an important source of genetic diversity in the human genome, and this type of variation cannot only induce phenotypic changes but can also affect an individual's susceptibility to disease. Tiling arrays were used to analyse in a comparative setting genomic variations causative for tumour development during cancerogenesis.

Human exome sequencing on a IlluminaHiSeq system were applied to extend resolution of genetic variations down to nucleotide level. In a customized setting of exome sequencing, each genomic region of interest can be analysed and used for later genotype-phenotype correlations, even in larger cohorts, within a reasonable time frame.

Genome sequencing/re-sequencing: Due to the enormous capacity of the Illumina Next Generation Sequencer (600Gb/10d) we could analyse numerous

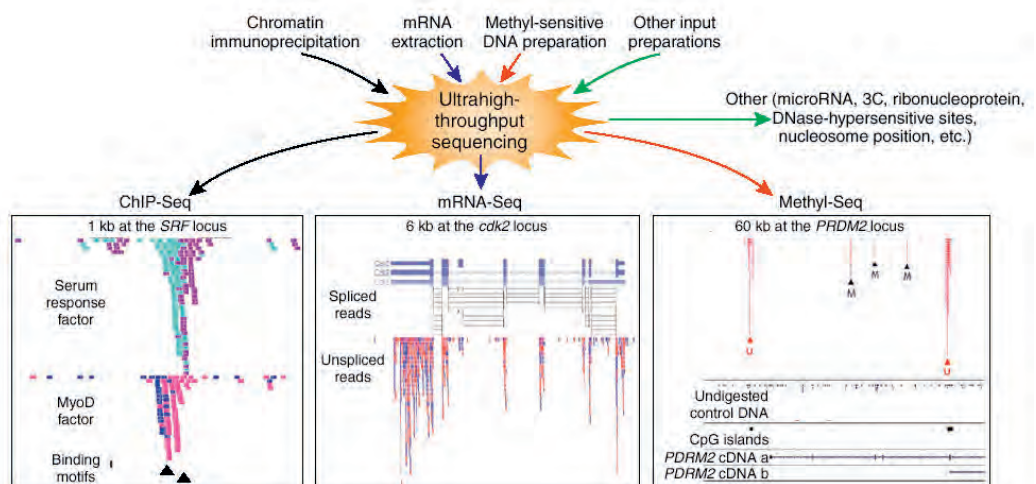

microbial genomes by *de novo* sequencing or re-sequencing strategies. One prominent project initiated recently was the identification of genomic antibiotic resistance markers (SNP, SNV) in clinical strains of *Pseudomonas aeruginosa* using comparative genome sequencing (→ MOBA, Prof. S. Häußler).

Transcriptomics

The transcriptome analysis has been an established application for many years and was widely used in numerous projects either initiated by HZI researchers or by external cooperation partners. The technologies behind are represented by Agilent microarray platform and the Affymetrix GeneChip® System. Both technologies belong to the superior class of microarray analytics systems and allow the investigation of the transcriptome of all common species (human, mouse, rat) as well as for customized microarray designs. Researchers have selected microarray formats allowing not only for transcript counting (gene arrays), but also the identification of splice variants (exon arrays). More recently a new technology was added to supplement the existing microarray technology. RNA-Seq allows the direct measurement of RNA transcripts by sequencing and, in addition, provides information about structure and sequence variation. In contrast to exon arrays, RNA-Seq shows also information about new, previously unknown splice variants. RNA-Seq can be used for any organism of interest.

Furthermore, the same strategies and technologies (microarray & sequencing) were successfully applied to micro RNA profiling.

Epigenomics

Epigenomic approaches analyse transcription factor binding, histone modification status (ChIP: Chromatin Immuno-Precipitation) and DNA methylation (MeDIP: methyl-DNA Immuno-Precipitation) of a particular genomic region. Researchers could select for two methodologies: Microarray based or Sequencing by Illumina HiSeq System. While the microarray system provides sample specific information about known epigenetic regions, sequencing allows in addition the detection of epigenetic modification of so far unknown genomic regions. Furthermore, due to sequencing of the DNA fragments, individual Cytosine modifications in CpG islands can be detected. Both technologies were applied to profile clinical samples (human tumours) as well as to analyse methylation pattern of immune cells derived from mouse model systems (→ EXIM, Prof. J. Hühn).

During the past years the GMAK has participated in a number of internal and external scientific projects as a collaboration partner, providing not only the technology but also supporting the data analysis and its interpretation. The major part of the projects engaged in include host-pathogen interactions, chronic diseases, tumour development, tumour typing, pathogen typing and the immune biology of the host organism.



Scientific Collaborators

Dr. Peter Husemann, Michael Jarek,
Prof. Dr. Frank Klawonn

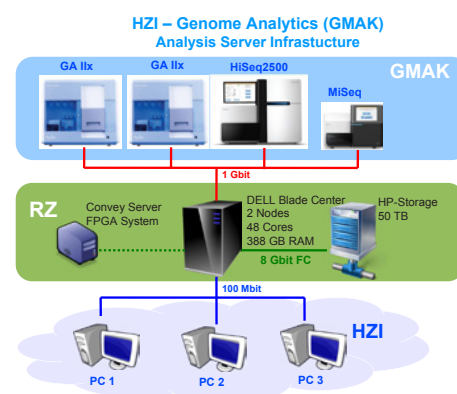

Genome Analytics HZI



Head

Dr. Dr. Werner Tegge

Department of Chemical Biology (CBIO)
werner.tegge@helmholtz-hzi.de

Peptide Synthesis

Since its inauguration as a service unit in 1990, the platform generates synthetic peptides, both in soluble form and immobilised in the form of arrays, for many different HZI projects and external collaborations. State-of-the-art equipment is employed for the synthesis, characterisation and purification. By participation in research projects, the methodological repertoires are continuously updated and extended.

Developments in this context include:

- New methodologies for the generation of peptide arrays, e.g. the SPOT method and the SC2 method for miniaturized arrays on glass slides
- Methods for the preparation of phosphorylated and thiophosphorylated peptides
- The utilisation of new biocompatible solid supports
- New selectively cleavable peptide linkers
- Methods for the synthesis of branched peptides
- Methods for the generation of libraries of linear and cyclic peptides
- Assays for the utilisation of soluble and immobilised peptides in biological systems
- Development of antimicrobial peptides and pathoblockers

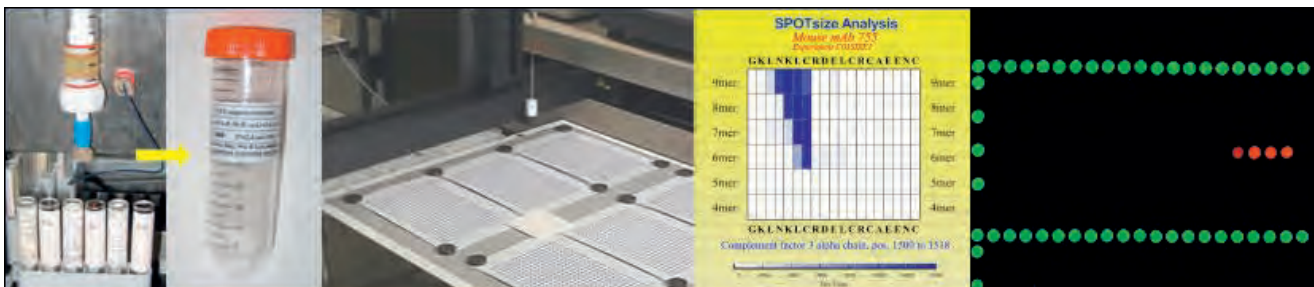

Soluble peptides (left two pictures) are prepared in dedicated synthesizers on polymeric solid supports and obtained after purification and lyophilization as white powders. Peptide arrays on cellulose membranes (SPOTs, middle picture) are assembled by pipetting activated amino acids onto the support. The arrays can be used e.g. in the elucidation and sizing of antibody epitopes (second picture from the right). The miniaturized arrays on glass slides (SC2 method, right picture) are used with fluorescent or chemoluminescent probes. HZI

Soluble peptides

To date, over 3,500 soluble peptides with a length of two to over fifty amino acids have been generated in the platform. Soluble peptides are characterized using HPLC and mass spectrometry. If necessary, further characterization is carried out by amino acid analysis, protein sequencing, special mass spectrometry techniques and NMR in the HZI Division of Structural Biology.

Depending on the intended usage and desired quality of the products, purifications are carried out, usually by preparative HPLC. For special applications, the platform also offers peptide modifications such as fluorescence labelling, phosphorylation, biotinylation, lipid conjugation, PEGylation, branched peptides and cyclisations.

SPOT-arrays

In the platform, immobilised peptides in the form of arrays are generated to facilitate the systematic and empirical search for ligands, enzyme substrates and inhibitors. For the successful design of such arrays, a thorough understanding of the biological context is essential, which is attained via close co-operation and collaboration with the users. The SPOT-arrays are generated semi- and fully automatically on cellulose membranes or glass slides. Each year, thousands of peptides and peptide mixtures are generated in an array format and utilised for the investigation of e.g. protein-protein interaction, including epitope mapping, and enzyme-substrate recognition.

Recent developments are miniaturized peptide arrays on glass supports that allow the expansion of individual synthesis products to thousands of probes.



Scientific Collaborator

Dr. Ronald Frank

Publications

Beutling, U. & Frank, R. (2010) Epitope analysis using synthetic peptide repertoires prepared by SPOT synthesis technology. In: Springer Protocols: Antibody Engineering (Kontermann, R. and Dübel, S., eds.), 537-572.

Tegge, W., Bonafe, C.F.S., Teichmann, A., & Erck, C. (2010) Synthesis of peptides from α - and β -tubulin containing glutamic acid side chain linked oligo-Glu with defined length. *International Journal of Peptides*, Article ID 189396.

Nickl, C.K., Raidas, S.K., Zhao, Sausbier, M., Ruth, P., Tegge, W. Brayden, J.E. & Dostmann, W.R. (2010) (D)-Amino acid analogues of DT-2 as highly selective and superior inhibitors of cGMP-dependent protein kinase I- α . *Biochimica et Biophysica Acta (BBA) – Proteins and Proteomics* **1804**, 524-532.

Weiß, S.M., Ladwein, M., Schmidt, D., Ehinger, J., Lommel, S., Städing, K., Beutling, U., Disanza, A., Frank, R., Jänsch, L., Scita, G., Gunzer, F., Rottner, K. & Stradal, T.E.B. (2009) IRSp53 links Tir to EspFU/N-WASP-mediated actin assembly in EHEC pedestal formation. *Cell Host & Microbe* **5**, 244-258.

Dikmans, A., Beutling, U., Schmeisser, E., Thiele, S., & Frank, R. (2006) SC2: A novel process for manufacturing multipurpose high-density chemical microarrays. *QSAR and Combinatorial Science* **25(11)**, 1069-1080.



Head

Dr. Marina Pils
 Mouse-Pathology Platform
 marina.pils@helmholtz-hzi.de

Mouse-Pathology

The mouse-pathology platform aims to provide state-of-art histo-pathological services and to contribute expertise in mouse-pathology to ongoing research projects at the HZI, TWINCORE and HIPS. Basic services include the preparation of histological slides with several standard, histo-chemical and immune-histo-chemical staining procedures. The platform provides expertise in mouse-pathology ranging from the preparation of organs via suitable staining methods to the evaluation of histological slides. Furthermore, the service unit offers equipment for cryo-sectioning and macroscopic, as well as microscopic, documentation.

Results

The most frequently used techniques included paraffin-embedding, sectioning and H&E-staining of formalin fixed organs. Aside from these basic techniques, the demand for special services such as the establishment of new histo-chemical and immune-histo-chemical (IHC) stainings, cyrosectioning and double IHC stainings is increasing. A modified Gram staining for the detection of bacteria in tissue, the massontrichrome staining for the differentiation of fibrin and collagen, the Giemsa/Pappenheim staining for differentiation of leukocytes, the combined PAS/Alcain blue staining for detection of glycoproteins and the kongored staining for amyloid were established according to the demand of the

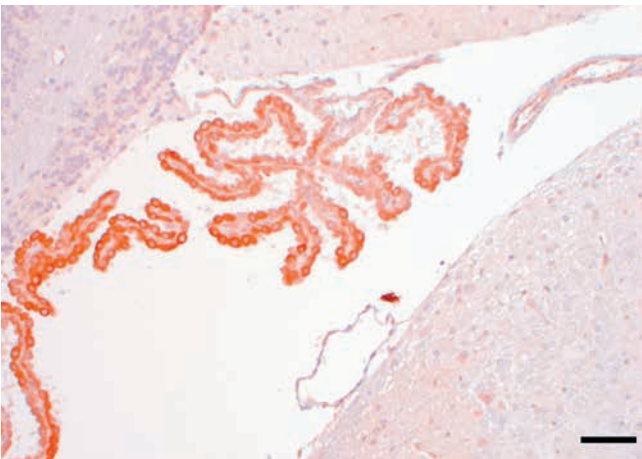

Anti-GFP staining (brown), choroid plexus, GFP transgenic mouse, bar = 50 μm HZI

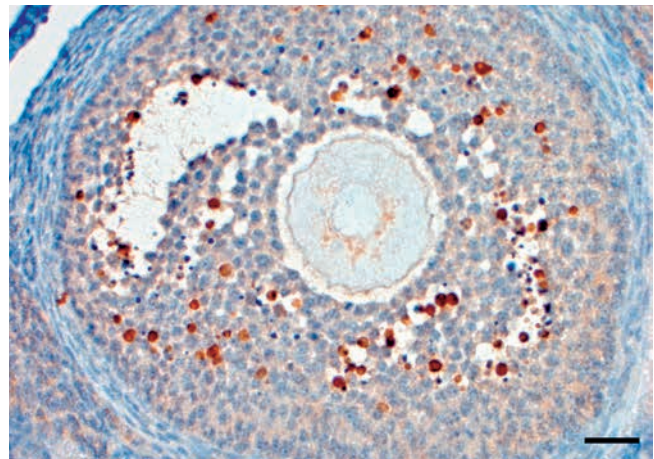

Anti-Caspase 3 staining (brown) showing apoptotic cells, ovary, wild-type mouse, bar = 25 μm HZI

research groups. Moreover, an anti-GFP, anti-MAC3, anti F4/80 and a CD3/B220 double staining were developed. In order to limit exposure to formaldehyde the standardized mouse necropsy was optimized by the acquisition of a down-ventilated bench, which allows preparation of mouse organs and perfusion fixation for neuronal pathology. Furthermore, the mouse-pathology platform invested in a new hybridizer to provide *in situ* hybridizations (ISH) to research groups. The main focus of the ISH will be the detection of nucleic acids from bacteria in tissue. Samples of more than 20 different research projects were analysed histo-pathologically. The analysis was mainly done with specifically developed semi-quantitative scores. Moreover, two transgenic mouse strains were subjected to histo-pathological phenotyping. An external cooperation with the Helmholtz Centre München, Institute of Pathology, was set up for scientific exchange.

The aim is to further adapt services to the requirements of the research groups and to increase the contribution to publications. Thus, the demand for histo-pathological service will be re-evaluated annually. Further special staining methods will be established according to the needs of the research groups.

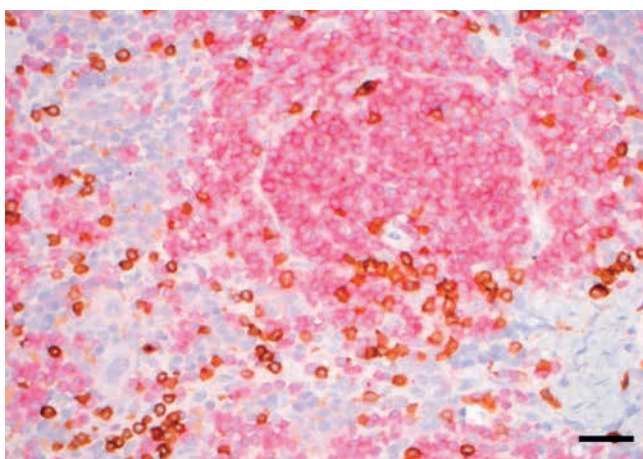

CD3/B220 double staining (brown = CD3 showing T-cells; blue = B220 showing B-cells), spleen, wild-type mouse, bar = 25 μ m HZI



Scientific Collaborator

Dr. Katrin Schlarmann

Publications

Avalos, A.M., Kirak, O., Oelkers, M., Pils, M.C., Kim, Y.M., Glage, S., Ottinger, M., Jaenisch, R., Ploeg, H.L. & Brinkmann, M.M. (2012) Cell-Specific TLR9 Trafficking in Primary Antigen Presenting Cells of Transgenic TLR9-GFP Mice. *The Journal of Immunology* **190**(2), 695-702.

Pils, M.C., Bleich, A., Prinz, I., Fasnacht, N., Bollati-Fogolin, M., Schippers, A., Rozell, B., & Müller, W. (2011) Commensal gut flora reduces susceptibility to experimentally induced colitis via T-cell derived Interleukin-10. *Inflammatory Bowel Diseases* **17**(10), 2038-2046.

Pils, M.C., Pisano, F., Fasnacht, N., Heinrich, J.-M., Groebe, L., Schippers, A., Rozell, B., Jack, R.S., & Müller, W. (2010) Monocytes/macrophages and/or neutrophils are the target of IL-10 in the LPS endotoxemia model. *European Journal of Immunology* **40**(2), 443-448.

Fuchs, B., Knothe, S., Rochlitzer, S., Nassimi, M., Greweling, M.C., Lauenstein, H.-D., Nassenstein, C., Müller, M., Ebensen, T., Dittrich, A.-M., Krug, N., Guzmán, C.A., & Braun, A. (2010) A Toll-like receptor 2/6 agonist reduces allergic airway inflammation in chronic respiratory sensitisation to Timothy grass pollen antigens. *International Archives of Allergy and Immunology* **152**(2), 131-139.

Fasnacht, N., Greweling, M.C., Bollati-Fogolin, M., Schippers, A., & Müller, W. (2009) T-cell-specific deletion of gp130 renders the highly susceptible IL-10-deficient mouse resistant to intestinal nematode infection. *European Journal of Immunology* **39**(8), 2173-2183.



Head

Dr. Dagmar Wirth

Service Unit Transgenic Mice (TGSM)
dagmar.wirth@helmholtz-hzi.de

Transgenic Mice (TGSM)

Genetically modified mice are an essential tool for a plethora of research activities including the elucidation of gene function, the verification of host-pathogen reactions, the validation of target structures and also for the development of novel experimental approaches.

This concerns in particular mice with modulated expression of endogenous genes (knock-out, knock-down) but also mice that give rise to controlled expression of transgene upon application of external triggers (drugs such as Tamoxifen or Doxycycline). Transgenic mice can be generated by specific genetic modification of pluripotent embryonic stem (ES) cells followed by subsequent transfer into blastocysts and implantation into foster mice. Chimeric offspring derived thereof are used to establish transgenic mouse lines. This procedure is being followed in the service unit 'Transgenic Mice' at the HZI (TGSM), relying on embryonic stem cell lines of various genetic background including 129, C57/Bl6 and hybrid F1 background as well as induced pluripotent stem cells (iPS).

Strategies are designed to generate novel transgenic mice with defined expression characteristics. Standard state-of-the-art technology is extended by implementation of tools that emerge from genetic engineering projects within the scientific project 'Cellular Models'. Well-characterized genomic sites with

Targeted integration of transgene cassettes into pre-selected chromosomal sites is achieved upon recombination mediated cassette exchange (RMCE) in embryonic stem cells (ES cells). This provides predictable expression in transgenic mice. HZI

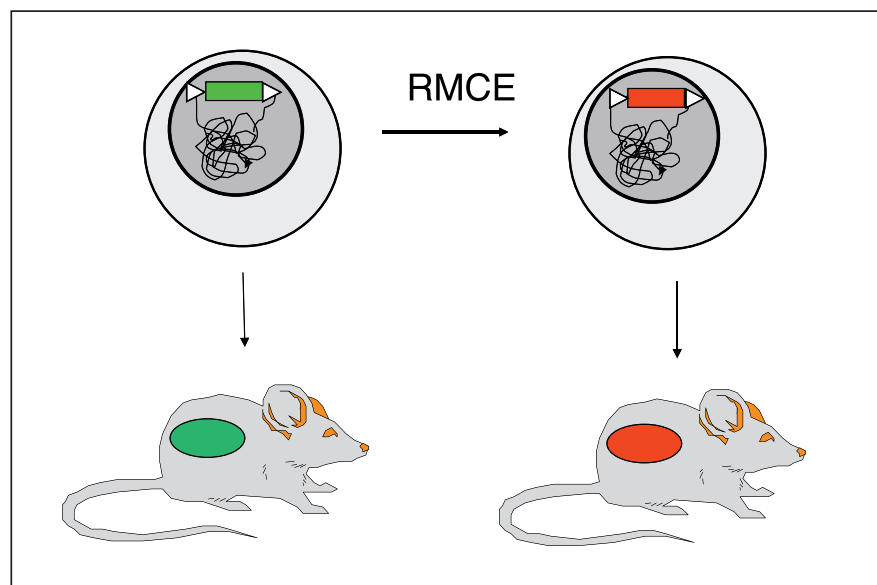

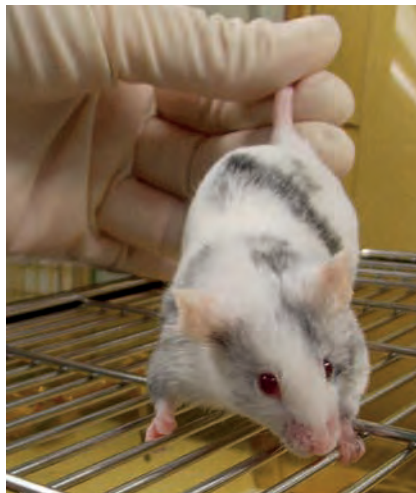
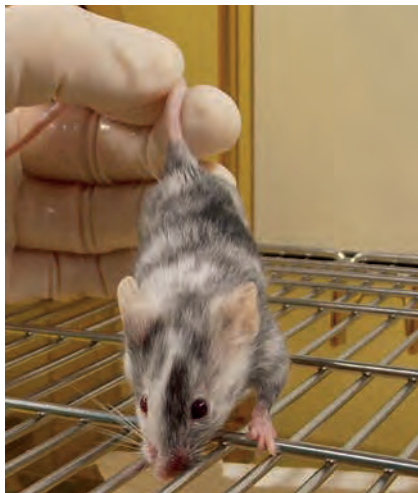

Chimeric mice generated upon injection of 129 X C57/Bl6 F1 ES cells in albino C57Bl/6 blastocysts HZI



Black and agouti: Transgenic progeny of a chimeric mouse. White: non-transgenic littermate. HZI

defined expression characteristics ('safe harbors') are exploited for integration of transgene cassettes. For this purpose, the sites are tagged with recombination target sites; transgene cassettes are integrated by the highly efficient and accurate process called recombinase mediated cassette exchange (RMCE) recently developed in this institute. Thereby, transgenic mice with predictable expression features of the respective genes are generated in a fast and efficient manner.

For tissue specific transgene expression, transgenes are integrated into the genome in a silent state and are activated upon Cre/loxP recombination upon breeding to the respective Cre effector mouse. Reversible activation of gene expression is achieved by implementing Tet-inducible expression cassettes and subsequent breeding to tTA or rtTA mice that induce transgene expression in a Tetracycline/Doxycycline dependent manner. For site specific genome manipulation, homologous recombination is pursued, thereby employing recent improvements facilitated by site specific nucleases (e.g. TALEN, CRISPR/Cas). Alternatively, transgenic mice are established upon manipulation of bacterial artificial chromosome (BAC) vectors that can ensure 'native' gene regulation within a given genomic context.

Publications

Sandhu, U., Cebula, M., Behme, S., Riemer, P., Wodarczyk, C., Metzger, D., Reimann, J., Schirmbeck, R., Hauser, H., & Wirth, D. (2011) Strict control of transgene expression in a mouse model for sensitive biological applications based on RMCE compatible ES cells. *Nucleic Acids Research* 39(1), e1.

Gama-Norton, L., Herrmann, S., Schucht, R., Coroadinha, A.S., Low, R., Alves, P.M., Bartholomae, C.C., Schmidt, M., Baum, C., Schambach, A., Hauser, H. & Wirth, D. (2010) Retroviral vector performance in defined chromosomal Loci of modular packaging cell lines. *Human Gene Therapy* 21, 979-991.

Nehlsen, K., Schucht, R., da Gama-Norton, L., Kromer, W., Baer, A., Cayli, A., Hauser, H. & Wirth, D. (2009) Recombinant protein expression by targeting pre-selected chromosomal loci. *BMC Biotechnology* 9, 100.

Wirth, D., Gama-Norton, L., Riemer, P., Sandhu, U., Schucht, R. & Hauser, H. (2007) Road to precision: recombinase-based targeting technologies for genome engineering. *Current Opinion in Biotechnology* 18, 411-419.



Head

Dr. Lothar Gröbe

Department Experimental Immunology (EXIM)
lothar.groebe@helmholtz-hzi.de

Flow Cytometry and Cell Sorting

In 2010, we founded a service unit to provide instrumentation and expert knowledge in flow cytometry for the phenotypic identification and functional analysis of cells at the single cell level. This technology plays a key role in the programme Infection Research, but is also used in collaboration with the TiHo Hannover, TU Braunschweig and FhG/ITEM Braunschweig.

Flow Cytometry

Our equipment park presently comprises of five flow cytometers for the analysis of cells.

Two cytometers are equipped with five lasers and 18 fluorescence detectors, enabling them to detect almost all currently available fluorochromes. This gives us the opportunity to develop several multicolour staining panels, e.g. for the identification and characterization of regulatory T cell and dendritic cell subsets, or for the analysis of the cytokine profiles of effector T cells.

Sorting of thymic dendritic cells (thyDC: CD45+CD11c+) and medullary thymic epithelial cells (mTEC: CD45-EpCAM+Ly51-) that are subsequently used in an in vitro assay. (Data courtesy of Garima Garg, EXIM) HZI

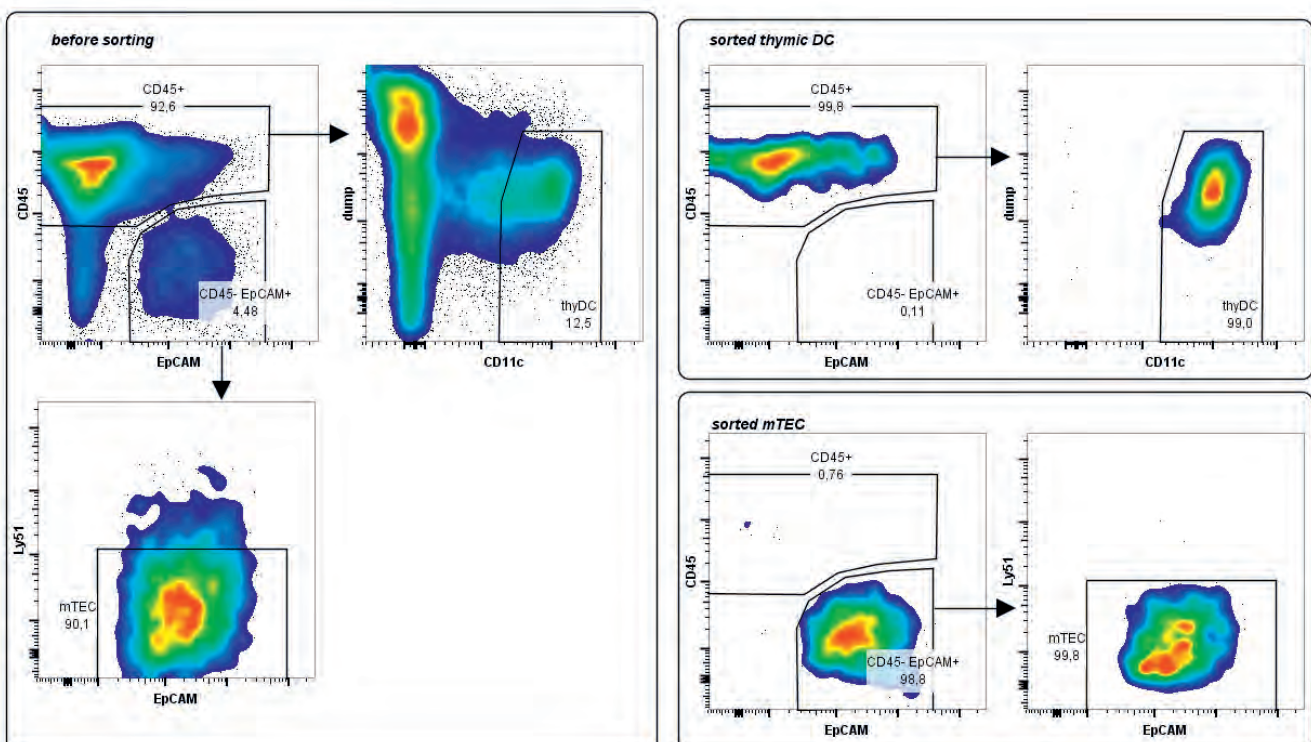

Other disciplines are using flow cytometry to characterize the cell wall of *Candida albicans*, to analyse gene expression regulation in *Yersinia pseudotuberculosis* and *Streptococcus pneumoniae* with GFP reporter systems, and to investigate the effect of bioactive compounds on the cell cycle progression or apoptosis induction.



Staff

Maria Höxter, Petra Hagendorff,
Beate Pietzsch

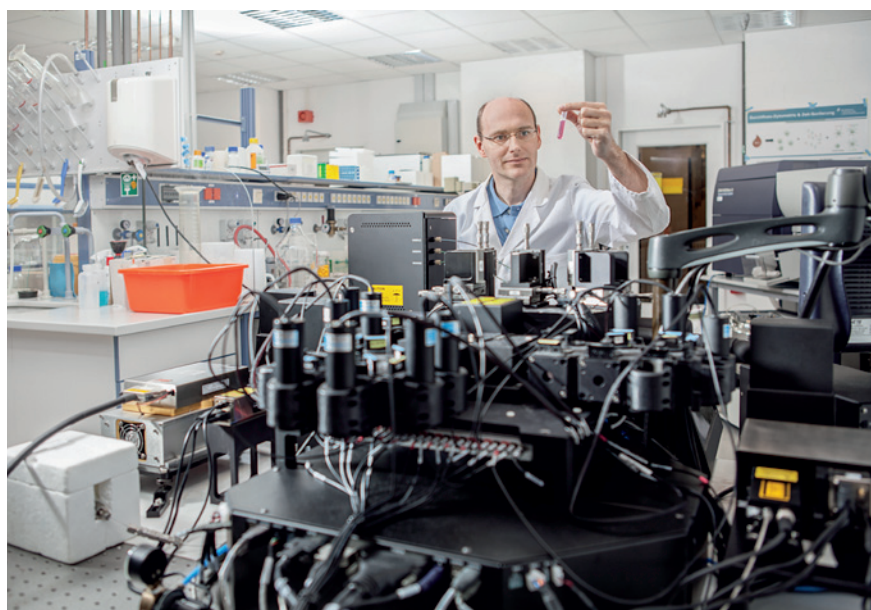

The cell sorting core facility HZI | T. Steuer

Cell Sorting

In addition to analytical flow cytometry, we are providing a cell sorting service.

Presently, we can offer four state-of-the-art cell sorter instruments, which are equipped with three or four lasers and up to 13 fluorescence detectors.

All instruments are high-speed sorters with the capability to sort four populations simultaneously at rates of up to 30,000 cells per second.

Cell sorting is used to purify specific cell populations out of complex mixtures. Rare cell types like naïve and regulatory T cells, dendritic cells, natural killer cells and other cell types of the immune system are sorted to high purity and are used for *in vitro* assays and adoptive transfer experiments. Another common application is the purification of rare cells for subsequent genomic analyses, like DNA methylation or transcriptome analyses.



Head

Prof. Dr. Manfred Rohde

Central Facility for Microscopy (ZEIM)
mro@helmholtz-hzi.de

Central Facility for Microscopy

The Central Facility for Microscopy will combine sophisticated light and electron microscopic imaging techniques for researchers of the HZI, TWINCORE and HIPS. Our mission is to undertake high quality imaging on a service and innovation basis. We intend to specialize on needs for imaging methods adapted to studies on infection processes. We like to bring light and electron imaging together with the focus on infectious processes of microorganisms. We want light and electron microscopic imaging to be a synergistic set of methods to unravel infection mechanisms. The combination of light and electron microscopic methodology will allow for an in-depth characterization of infection processes of microorganisms at high resolution. Imaging, especially high resolution FESEM, is the only available technique for direct visualization of the infection process in the context of the surrounding morphology of the host cells. Confocal microscopy allows only for the detection of fluorescence labeled or fluorescence-based expression of proteins or structures with no further morphological details of the host cell but with the advantage to follow *in vivo* movements of marked proteins or structures.

The imaging facilities offer use of basic light microscopic methods and fluorescence microscopy on a Zeiss Axio Imager1 and Observer Z1 with an incubation chamber. For confocal microscopic studies a Zeiss LSM510 Meta, a Leica SP5, a Leica live imaging microscope with incubation chamber and a Perkin Elmer UltraView spinning disk microscope with TIRF (total internal reflex fluorescence) are available. For S3-based infection work, a Perkin Elmer UltraView spinning disk and a Nikon Eclipse N1 fluorescence microscope are installed in the S3-unit. The equipment allows for an extensive coverage of a wide spectrum of imaging methods such as double or multiple immune fluorescence stainings, live cell imaging, FRET, FRAP and FLIM. For intravital imaging, access to the multiphoton microscope at the Magdeburg University will be established. For electron microscopic studies, a state of the art field emission scanning electron microscope (FESEM) Zeiss Merlin and an energy filtering transmission microscope (EFTEM) Zeiss Libra 120Plus are installed. In addition, a Zeiss EM910 serves for basic transmission electron microscopic studies. Electron microscopic studies will be provided as a service for the campus and covers, for example, immune labelling on ultrathin sections or for scanning electron microscopy on sample surfaces, in-depth analysis of infection processes by high

resolution FESEM, analysis by ultrathin sections of high pressure frozen and freeze substituted samples, conventional embedded samples or visualization of quaternary structures of proteins by negative-staining. For light and confocal studies a compulsory training will be implemented before allowing usage of the equipment. The overall goal in the future will be to combine fluorescence and electron microscopy in high resolution correlative light and electron microscopy (CLEM) of the same sample.



Scientific Collaborator
Katja Branitzki-Heinemann

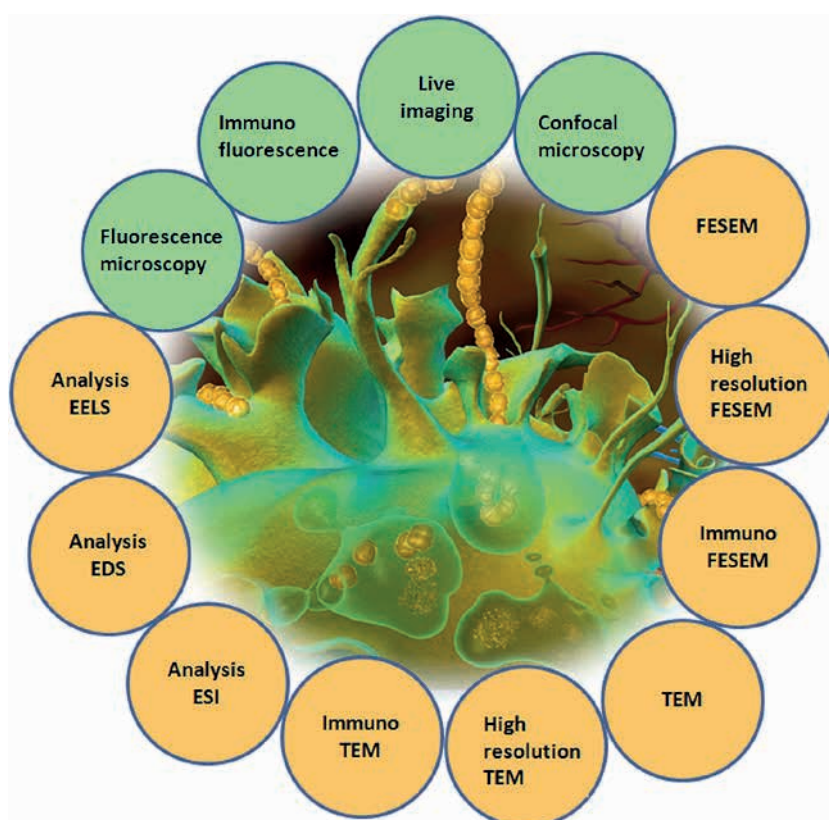

Available imaging methods for studying infection processes (ESI electron spectroscopic imaging, EELS electron energy loss spectroscopy, EDS energy dispersive x-ray spectroscopy, TEM transmission electron microscopy, FESEM field emission scanning electron microscopy) HZI

The Central Facility for Microscopy will support research projects by providing imaging expertise, collaboration and imaging services, especially for electron microscopic imaging based technologies. Furthermore, we shall provide training and assistance in basic and advanced light microscopic methods and basic confocal microscopy methodology. In addition, ongoing technical consultation and support will be provided.





HIPS

The Helmholtz-Institute for Pharmaceutical Research Saarland



TWINCORE

Centre for Experimental and Clinical Infection Research GmbH



DZIF

German Centre for Infection Research

Photos from left to right:

Liang Quiong and Anne Paulus (background) preparing for microscopical analyses (HIPS) | Dr. Alexander Ploss, Rockefeller University, was one of the speakers of the 4th TWINCORE symposium (TWINCORE) | The Executive Board of the German Centre for Infection Research at the Opening Ceremony in December 2012 in Berlin (from left to right: Dirk Heinz, Ulrike Protzer, Martin Krönke) (DZIF)

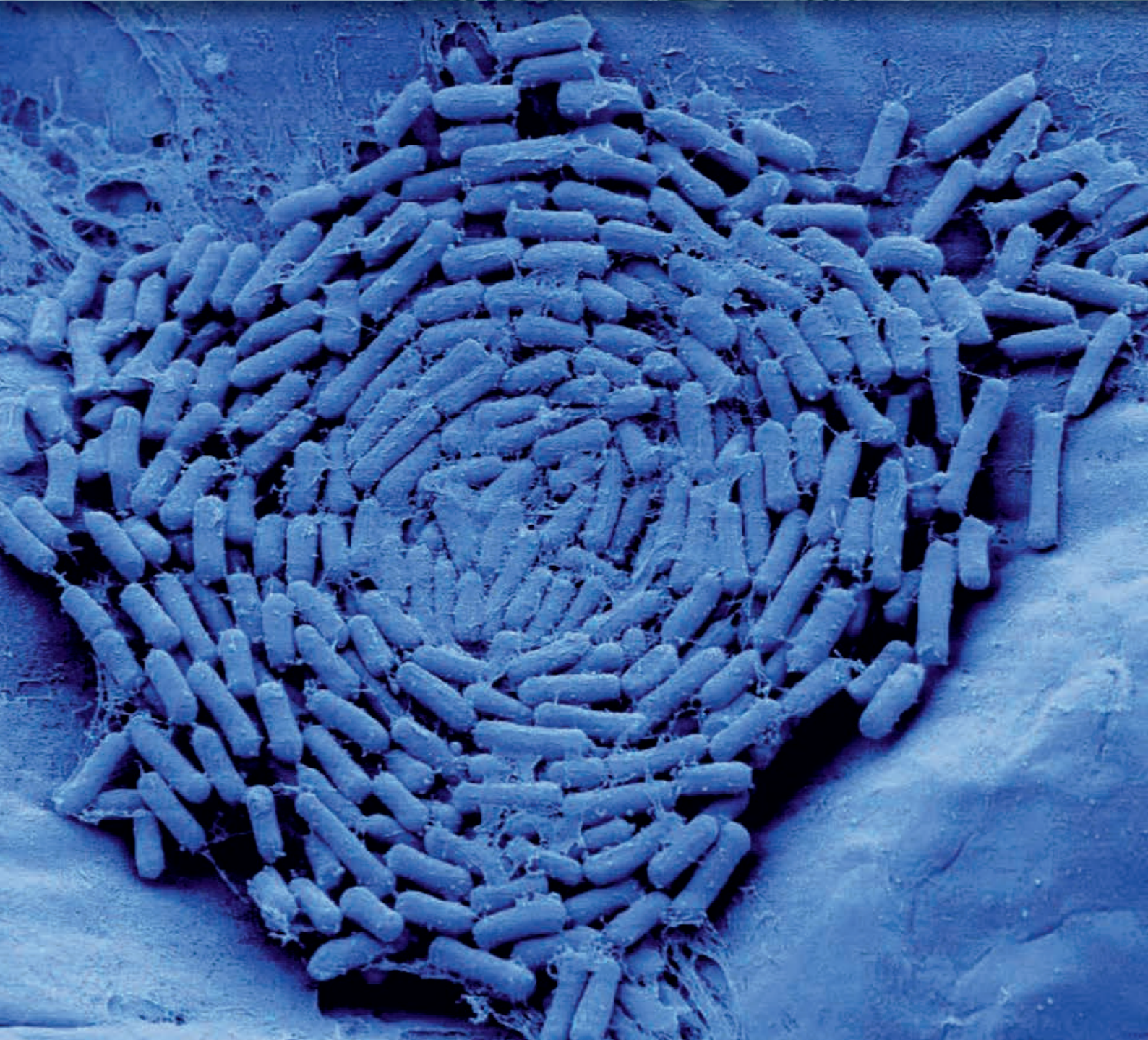

THE HELMHOLTZ-INSTITUTE FOR PHARMACEUTICAL RESEARCH SAARLAND (HIPS)

Helmholtz-Institute for Pharmaceutical Research Saarland



Draft © ARCHITEKTEN BDA RDS PARTNER



European Union
European Regional Development Fund
Investing in Your Future

THE HELMHOLTZ-INSTITUTE FOR PHARMACEUTICAL RESEARCH SAARLAND (HIPS)

Increasing (multi)-resistance towards established antibiotics is a serious medical problem. Re-emerging and new infectious diseases are of equal concern. In addition, the development of new drugs against such illnesses is currently based mainly on known mechanisms of action and old molecule scaffolds, which allows bacteria to develop and spread resistance rapidly. There is thus an urgent need for new strategies aimed at the discovery and development of novel anti-infective pharmaceuticals: This is the research focus of the Helmholtz-Institute for Pharmaceutical Research Saarland (HIPS).

Antibiotics have been used successfully for the last 70 years. Since their introduction the mortality rate from infectious diseases has fallen dramatically. However, these drugs have been applied so widely and for so long that the infectious organisms have adapted to them, making these drugs less effective. Once restricted almost exclusively to developing countries, resistant pathogens are now spreading in hospitals and in communities in developed countries as well. Research to develop novel antimicrobial drugs is required – and this is precisely the issue that is being tackled by the Helmholtz-Institute for Pharmaceutical Research Saarland (HIPS).

The Institute was founded in 2009 in Saarbrücken, Germany, following a positive international evaluation of a joint proposal from the Helmholtz Centre for Infection Research (HZI) and Saarland University (UdS). The HIPS is the first non-university based research facility in Germany that is explicitly devoted to pharmaceutical research, and it

is closely integrated into UdS on the basis of a cooperation agreement between the HZI and UdS. As a branch of the HZI, the HIPS is involved in the activities of the “Health” research field of the Helmholtz Association and the “Infection and Immunity” research program.

EXPERTISE ON INFECTIOUS DISEASES AND PHARMACEUTICAL RESEARCH

The range of scientific work at the HIPS comprises genetic and genome-based methods for optimizing natural product producers and lead compounds as well as methodologies to improve the transport of pharmaceutical agents to their target. The combination of the HZI’s knowledge of infectious diseases and the HIPS’ pharmaceutical research puts the HIPS in a unique position both in Germany and in Europe, especially regarding the development of anti-infectives.

HIPS

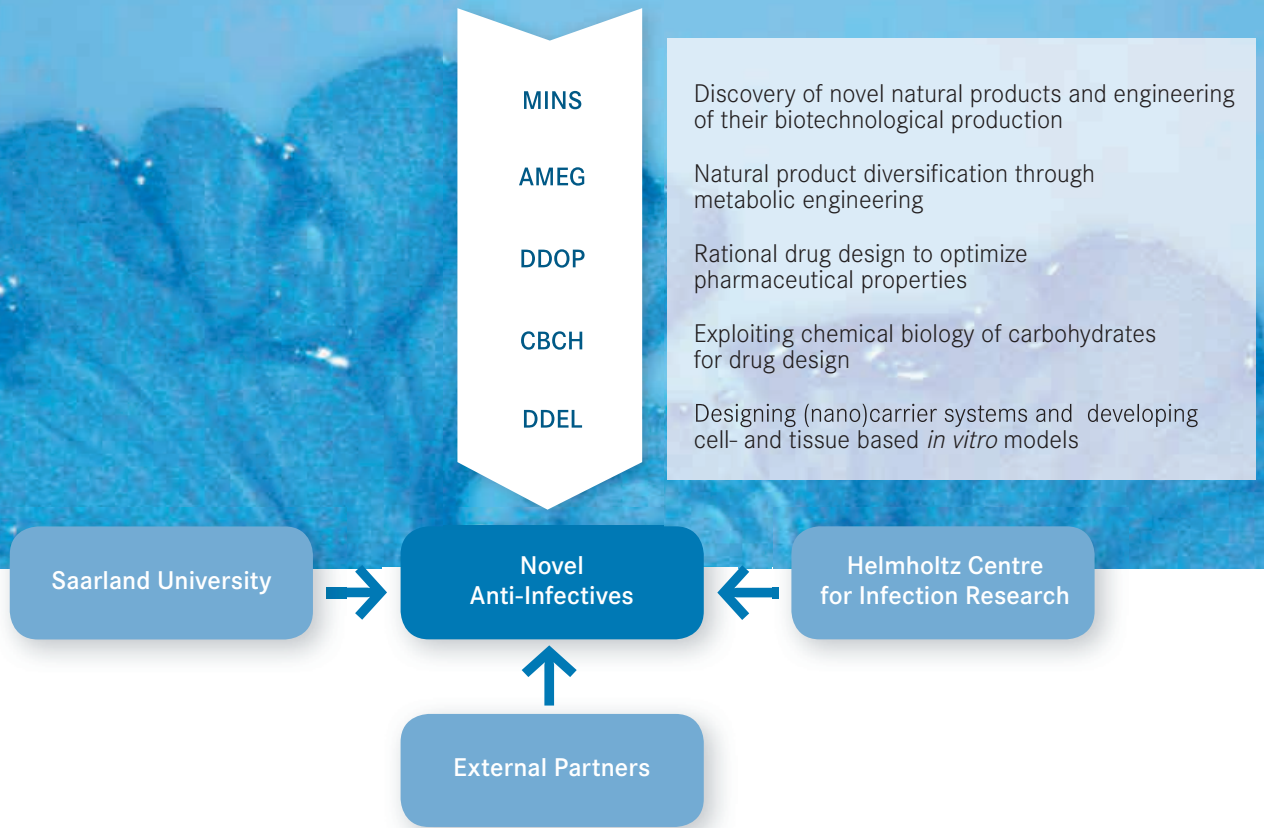



This complementary expertise allows concerted and synchronous approaches towards the discovery and mining of novel producers for potential drugs, their rational improvement and bioprofiling, as well as their optimal formulation. This combination of expertise greatly enhances the probability of identifying and utilizing novel natural products, and accelerates their advancement to

(pre)clinical studies. The combined research activities and experience of scientists at the HIPS, the HZI and further regional and international cooperations in drug development make it possible to cover drug development in its entirety from early drug discovery to clinical phase studies. A successful implementation of translational research is thus achieved.

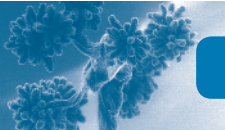
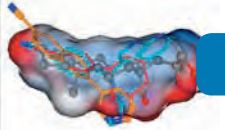
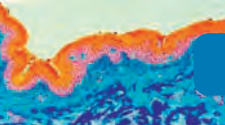
DEPARTMENTS AT THE HIPS

	MINS	Microbial Natural Products
	DDOP	Drug Design and Optimization
	DDEL	Drug Delivery

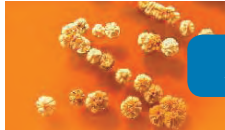
JUNIOR RESEARCH GROUP

	AMEG	Actinobacteria Metabolic Engineering
	CBCH	Chemical Biology of Carbohydrates

HIPS EVENTS TO EXCHANGE IDEAS

The HIPS regularly organizes events which bring together renowned scientists and young investigators from three pharmaceutical communities: Natural products, medicinal chemistry and drug delivery. The HIPS Symposium provides a forum for senior scientists to exchange ideas while crossing the boundaries of classical disciplines. At the same time it gives young investigators the opportunity to obtain valuable feedback on their projects from international experts in the respective fields. The plan is to establish the HIPS Symposium as a creative meeting with a regular place in the schedule of leading scientists from these research fields in Europe and beyond. The HIPS Talk invites scientists from different disciplines who are interested in pharmaceutical research from faculties and public research institutes to the Saarland University campus. Other events, like workshops, are an additional part of the creative development process.

The HIPS originates from three pharmaceutical research departments of Saarland University headed by Professors Rolf Müller (Managing Director of the HIPS and former scientist at the HZI), Rolf W. Hartmann and Claus-Michael Lehr. Rolf Müller's research focuses on the exploitation of microbial agents, primarily from myxobacteria (MINS Department, Microbial Natural Products), Rolf Hartmann's Department specializes in pharmaceutical and medicinal chemistry (DDOP Department; Drug Design and Optimization) while Claus-Michael Lehr investigates the targeted transport of drugs to the source of disease (DDEL Department; Drug Delivery).

From 2009 to presumably 2014 (by when it is expected new appointments will have been made to the chairs of pharmacy at UdS), the three professors hold chairs of pharmacy at UdS and are also department heads at the HIPS, so that their research groups originate from both UdS and the HIPS. Currently, two junior research groups are located at the HIPS: The AMEG group headed by Andriy Luzhetskyy specializes in the engineering of actinobacteria, while Alexander Titz's research focuses on the Chemical Biology of Carbohydrates (CBCH).

In 2015 the new HIPS building on the UdS campus will be completed, and all HIPS departments, junior research groups and infrastructures can then be accommodated under one roof.



HIPS Symposium

The HIPS is funded by the German Federal Government and the Federal State of the Saarland and has an annual budget of 5.5 million euros. Since the foundation of the HIPS the Helmholtz Association has also been represented in the Saarland. As Germany's largest scientific research organization the Helmholtz Association contributes to solving the grand challenges of society, science and industry by performing cutting edge research in the fields of Energy, Earth and Environment, Health, Key Technologies, Structure of Matter, Aeronautics, Space and Transport. The Association has an annual budget of 3.8 billion euros and almost 34 000 collaborators undertake research into systems of great complexity with large-scale facilities and scientific infrastructure, cooperating closely with national and international partners.

See also: www.helmholtz.de/en/partners.

MINS

THE DEPARTMENT “MICROBIAL NATURAL PRODUCTS”

Natural products of microbial origin continue to be very promising sources for the development of pharmaceuticals. Compared to synthetic compounds, natural products cover a unique chemical space and they are also thought to be evolutionarily optimized binders for various biological targets. They can exhibit diverse biological activities and modes-of-action, making them useful for numerous therapeutic applications like the treatment of infections or cancer. However, finding and developing new bioactive compounds, so-called secondary metabolites, from microorganisms is a challenging task. The overall success depends on good sources (proficient microbial producer strains) as well as the professional interplay of various interdisciplinary approaches. The research in the “Microbial Natural Products” Department aims to exploit the rich biosynthetic potential of microorganisms, especially soil-dwelling myxobacteria, for the production of novel natural products.

DISCOVERY OF NOVEL BIOACTIVE COMPOUNDS

An on-going, world-wide strain discovery programme, in close collaboration with the “Microbial Drugs” Department at the HZI in Braunschweig, aims to identify new myxobacterial species, genera and families. Once new isolates have been successfully adapted to growth under laboratory conditions, cultivations are performed and culture extracts are then screened for promising bioactivities mainly against

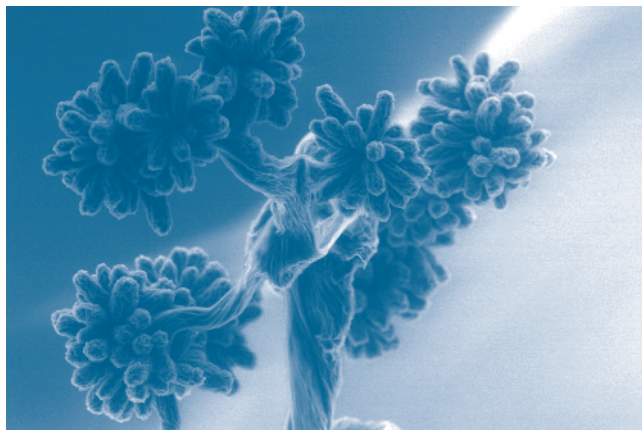

Chondromyces crocatus fruiting body, containing large numbers of myxospores

human pathogens. The discovery of novel natural products is underpinned by state-of-the-art analytical techniques, which allow an in-depth analysis of the strain’s secondary metabolite profiles. The scientists also decipher the genetic information of the bacteria to obtain comprehensive insights into their metabolic capabilities. As many natural product biosynthesis pathways are not active and considered to be ‘silent’ under standard cultivation conditions, several tricks are applied to activate these pathways and to ‘mine’ the genomes for all potential secondary metabolites. New compounds are isolated from culture extracts using a range of available separation techniques, and when necessary production scale-up is accomplished by fermentation on the 100 liter scale to isolate enough material for structure elucidation and further biological studies.

OPTIMIZATION OF BIOTECHNOLOGICAL PRODUCTION

Following the discovery of new natural products exhibiting promising activity, different strategies are applied to improve both their production yields and their structures, e.g. to optimize their pharmaceutical and pharmacological properties. To this end, an in-depth investigation of the underlying biosynthetic mechanisms and regulatory networks controlling production is performed. Based on these results rational production engineering is carried out by genetic manipulation of the producer strains or by transferring complete natural product biosynthetic pathways into suitable host strains for heterologous production. Overall, these synthetic biotechnology endeavors aim at translating early natural product hits into clinical application.

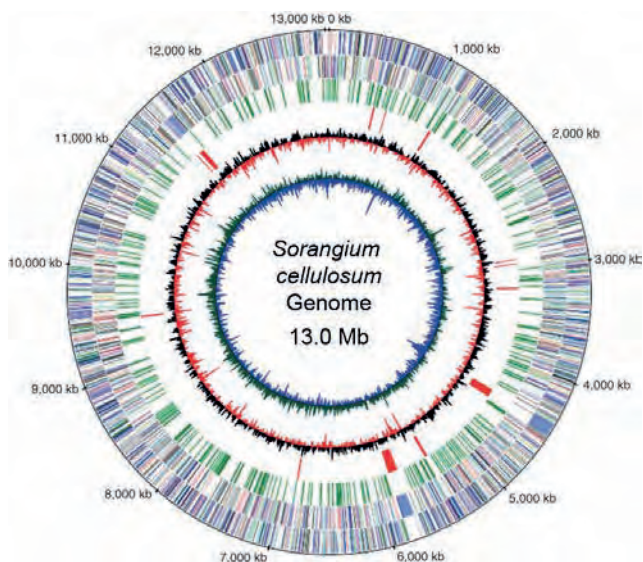

Map of the circular *Sorangium cellulosum* So ce56 genome

Rolf Müller's group provides a highly interdisciplinary research environment, where a broad spectrum of techniques, including microbiological, molecular-biological, genetic, biochemical, analytical and bioengineering methods, are combined to exploit microbial natural products for drug discovery and development approaches.

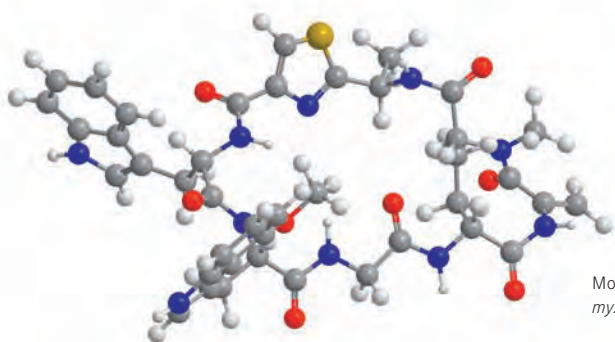

Molecular structure of Argyrin, a metabolite from *myxobacteria* showing antibacterial activity



High-resolution mass spectrometry platform for the in-depth analysis of secondary metabolomes

DDOP

THE "DRUG DESIGN AND OPTIMIZATION" DEPARTMENT

Recent advances in microbiology have resulted in the identification of an increasing number of natural products which exhibit antibiotic activity. However, most of these structures are not suitable to be used as drugs due to their unfavorable pharmacokinetic properties, such as poor solubility or difficult large-scale synthesis. The Department of "Drug Design and Optimization" focuses on the development of novel synthetic antibiotics, which can either be derivatives of natural products with improved druglikeness or synthetic compounds based on a rational drug design. Diverse strategies of medicinal chemistry are applied. Currently, the Department is working on two projects: The synthesis of antibiotic compounds targeting either the bacterial growth or the cell-to-cell communication.

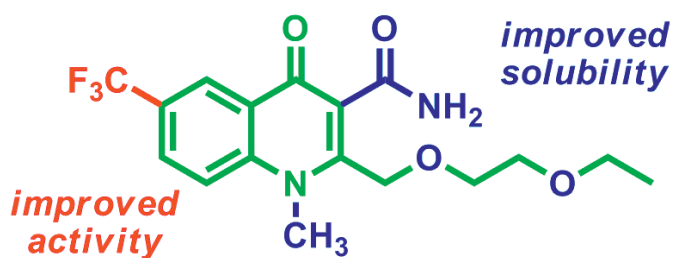

Rational development of antivirulence compounds with improved physicochemical properties

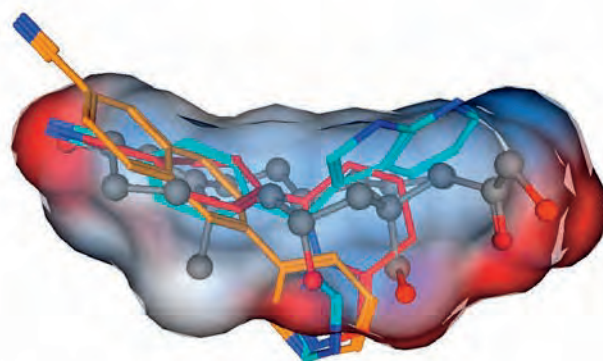

NOVEL RNAP INHIBITORS STOP BACTERIAL GROWTH

The bacterial RNA polymerase (RNAP) is essential for bacterial growth and is well conserved between different bacteria.

However, marketed RNAP inhibitors have evoked resistant strains by point-mutations in their binding sites. Rolf Hartmann's group aims to develop bacterial RNAP inhibitors with novel modes of action. It applies different methods such as ELISA- and SPR-based experiments as well as classical enzyme inhibition assays. The group utilizes computer-aided drug design (CADD) strategies to understand RNAP inhibition and to spark new ideas for drug design. Besides improving the RNAP inhibitory and antibacterial activity, DDOP aims to elucidate the mode of action and to optimize the pharma-

cokinetic properties of novel compounds. These endeavors should lead to new and highly potent antibiotics to be used in therapeutic applications in humans.

INTERFERING WITH CELL-TO-CELL COMMUNICATION IN BACTERIA

In a second project, the scientists of the DDOP Department develop compounds that interfere with the cell-to-cell communication in the bacterium *Pseudomonas aeruginosa*. Lung infections caused by this pathogen are difficult to treat when bacteria arrange themselves into clusters, so called biofilms. These dense layers suppress the uptake of antibiotics. The formation of biofilms and also the production of virulence factors are controlled by cell-to-cell communication systems (quorum sensing) in response to signal molecules. *Pseudomonas aeruginosa* has a third unique communication system which is regulated by PQS (Pseudomonas Quinoline Signal) as a signalling molecule. The DDOP Department aims to develop compounds that interfere with the PQS-dependent signalling in order to prevent the formation of biofilms and the production of virulence factors, without affecting the microbial viability.

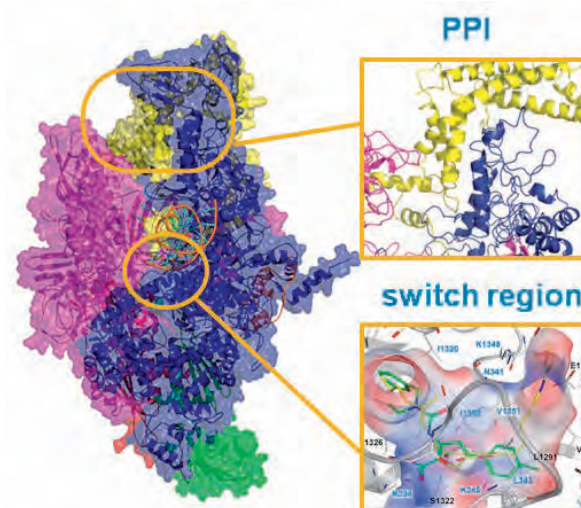

Structure of *E. coli* RNA polymerase. Inhibitors can be designed to target e. g. protein-protein interactions (PPI); defined binding sites can be used to develop a pharmacophore (ph4) model.



Chemical synthesis of small molecule antibacterial agents

DDEL

THE DEPARTMENT “DRUG DELIVERY”

Advances in molecular biotechnology and medicinal chemistry have led to the discovery of new drug candidates. However, developing these molecules into actual pharmaceuticals first requires the screening of their biochemical properties and their ability to cross biological barriers.

Scientists must establish new technologies to ensure the safe and effective delivery of the drug candidate to the site of action, for example the site of infection or components of the immune system. Therefore, the main focus of the “Drug Delivery” Department is on the exploration of the biological barriers themselves, which are present between the sites of drug administration and drug action.

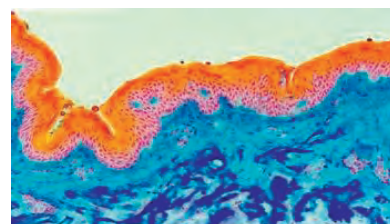

DISEASE-RELEVANT MODELS WITHOUT ANIMAL EXPERIMENTS

An important line of the research focuses on laboratory cell culture models to study the epithelial barriers of the lungs, the gastro-intestinal tract, and the skin under controlled conditions *in vitro*. The establishment of disease-relevant *in vitro* models for infections and/or inflammation of the respective barriers allows the therapeutic efficacy of novel drug candidates to be demonstrated via adequate biomarkers without using animal experiments. Such models make

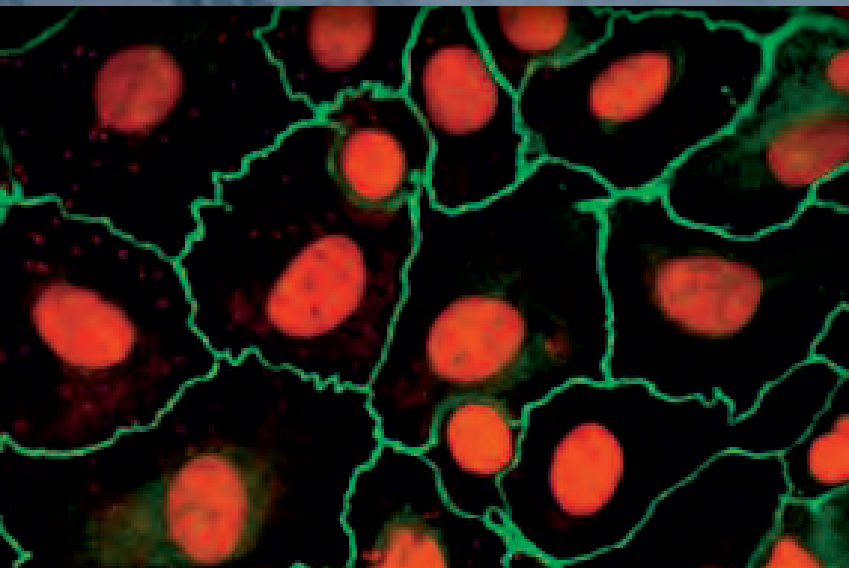

it possible to perform pre-screening or high throughput screenings of drug candidates as well as a detailed investigation of transport mechanisms in an environment which is less complex than the *in vivo* situation – the situation in living organisms. Similarly, such models also have considerable potential as alternatives to animal testing in the drug development process.

The Department headed by Claus-Michael Lehr has developed an *in vitro* co-culture model for inflamed intestinal mucosa. The model, honored by two animal welfare awards from the German Federal Ministry of Food, Agriculture and Consumer Protection (BMELV) and the State of Rheinland-Pfalz, has been successfully applied to the testing of first anti-inflammatory formulations. In collaboration with other groups at the HZI, this *in vitro* model will be applied to identify epithelial inflammation markers and to study mechanisms of bacterial adhesion and invasion of enteropathogens. Understanding and mimicking the bacterial invasion pathway will allow even more effective targeting of diseased areas and increased

cellular internalization of drug carriers, by using invasion decorated particles, for example. Furthermore, other complex, disease-relevant *in vitro* models are being studied by developing both a co-culture model.

CARRIER SYSTEMS CROSSING BIOLOGICAL BARRIERS

A second major research line of the “Drug Delivery” Department consists of developing appropriate carrier systems that are capable of crossing biological barriers and thereby improving the delivery of the active molecule to the target. This is particularly relevant in the context of macromolecular biopharmaceuticals such as peptides, proteins, and RNA or DNA based drugs. In parallel, the nanotechnology platform, part of the Department, is to be advanced and broadened in terms of formulating multifunctional nanocarriers that allow tracking of the carriers, targeting to the site of action and release of the payload in a controllable manner both *in vitro* and *in vivo*. Last but not least, the carrier systems must be safely eliminated from the body, preferably by biological degradation of their constituents. Taken together, DDEL researchers are interested in a deeper understanding of the function of biological barriers in the healthy and the diseased state as well as in their interaction with (nano) particulate drug carriers.



Developing carrier systems that are capable of crossing biological barriers

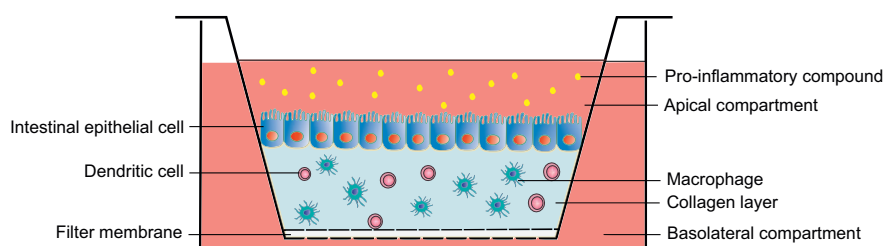

Experimental set-up of the co-culture consisting of an intestinal epithelial cell line, macrophages and dendritic cells

AMEG

JUNIOR RESEARCH GROUP: “NATURAL PRODUCT DISCOVERY BY ACTINOBACTERIA METABOLIC ENGINEERING”

Actinomycetes are a well-known and very intensively investigated group of bacteria. They have produced various antitumour drugs and are used industrially to produce antibiotics. Despite their track record in antibiotic production, a huge potential still remains to be revealed: Actinomycetes have about 30 biosynthetic gene clusters which are responsible for natural product biosynthesis - the function of most of them is still unknown. Whole complexes of genes are not active under normal laboratory conditions. In most cases it is not yet known how these “silent genes” are switched on and which substances they produce in an active state.

The HIPS “Actinobacteria Metabolic Engineering” Junior Research Group activates such genes in the microbial genome: Powerful and efficient instruments for highthroughput genetic analysis of actinobacteria are provided by special enzymes like site-specific recombinases, transposases,

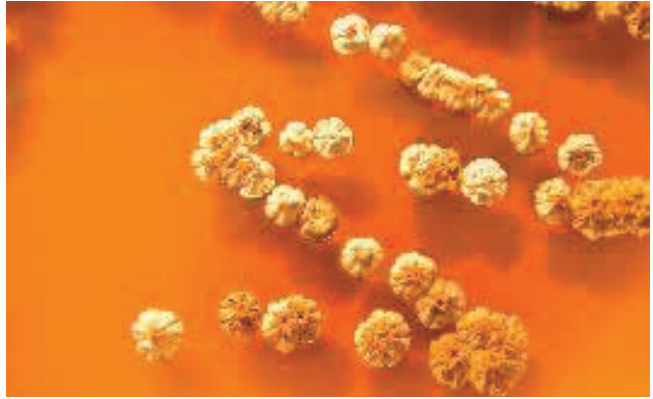

Streptomyces sp. isolated in the Nikitsky Botanical Garden of Crimea (Ukraine)
HIPS/Luzhetskyy

I-SceI meganuclease and beta-glucuronidase based systems. Those recently developed genetic tools are being used for the construction of synthetic biobricks, the identification of regulatory networks, which are responsible for “silencing” natural products biosynthesis, and the generation of suitable hosts for the antibiotic production and activation of “cryptic” biosynthetic gene clusters. Andriy Luzhetskyy’s group anticipates that the methods will provide new possibilities for the study of functional gene expression in actinomycetes and eventually lead to natural product discovery.

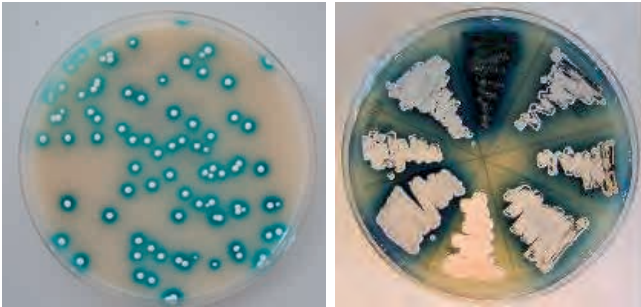

Different transposon mutants of *Streptomyces coelicolor* M145





CBCH

JUNIOR RESEARCH GROUP: “CHEMICAL BIOLOGY OF CARBOHYDRATES”

Carbohydrates and glycoconjugates belong to the three major classes of biopolymers. Complex carbohydrates play important roles in biological recognition processes, which are represented by the presence of dense glycoconjugate layers on cells, known as the glycocalyx. Despite their importance, the study of carbohydrates suffers because of the limited methods available for their synthesis and analysis, a problem not experienced with the study of nucleic acids or proteins.

TREATMENT OF CHRONIC INFECTIONS: DISRUPTING LECTIN-MEDIATED BIOFILMS

Many human pathogens can establish chronic infections with the help of a biofilm mode of life. As a protective shield, the matrix of the biofilm renders antibiotics ineffective and ensures the survival of the embedded pathogen. Novel ways for treatment address the disintegration of such biofilms, and thus restore the activity of antibiotics. The architecture of biofilms is frequently maintained by carbohydrates and so-called lectins, which recognize and crosslink carbohydrate motifs of the glycocalyx, both on human cells and pathogens. The inhibition of such structural components leads to the disruption of a biofilm and thereby allows treatment of the infection. *Pseudomonas aeruginosa* is an important pathogen in hospital-acquired infections and for cystic fibrosis patients. This Gram-negative bacterium can establish chronic infections in various tissues by accumulating into protective biofilms. One focus of the research here is on two *P. aeruginosa* lectins, which are crucial elements of the biofilm architecture.

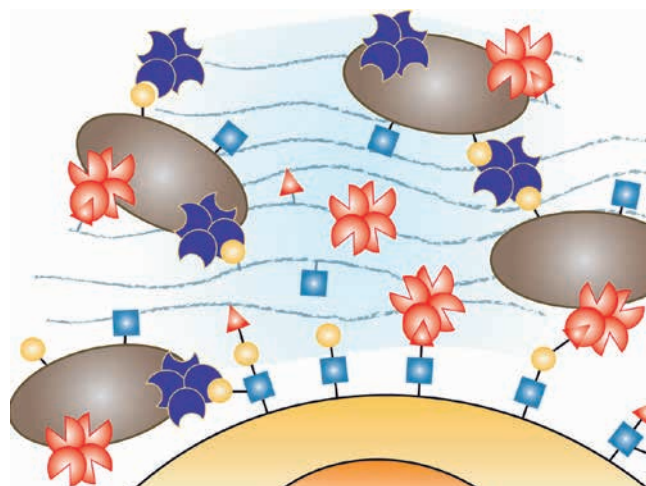

The group headed by Alexander Titz aims to develop anti-bacterial drugs using a combination of medicinal chemistry, biochemistry and microbiological methods. Recently, a competitive binding assay was developed for the *in vitro* evaluation of inhibitors of the *Pseudomonas* lectins. In collaboration with other groups at the HIPS and the HZI, potent molecules obtained by the group are then evaluated further in biofilm and infection models. Such compounds may ultimately lead to the successful treatment of chronic infections without evoking resistance among the pathogens.

Prof. Dr. Rolf Müller,
Managing Director of the Helmholtz-Institute
for Pharmaceutical Research Saarland (HIPS)
and Head of the
“Microbial Natural Products” Department



INTERVIEW

Rolf Müller studied pharmacy at Bonn University and obtained his PhD at the Department of Pharmaceutical Biology. In 1996, he went to the Department of Chemistry at the University of Washington in Seattle, USA. This was when he began to investigate the production of antibiotics in bacteria. Two years later he returned to Germany as a junior group leader at the German Research Centre for Biotechnology (GBF, now the HZI) in Braunschweig. In 2000, he completed his habilitation thesis at the Technische Universität Braunschweig on the biosynthesis of antibiotics in actinomycetes and myxobacteria. Since October 2003, Rolf Müller has held a chair as professor of Pharmaceutical Biotechnology at Saarland University. His research has already earned the Phoenix-Pharmacy Research Award twice, the DECHEMA Award for Natural Products Research, the BioFuture Award of the German Federal Ministry for Education and Research, and the DECHEMA Award of the Max-Buchner Research Foundation. Since 2012 he has been a member of the German National Academy of Science and Engineering.

In 2009 Rolf Müller became the Director of the Helmholtz-Institute for Pharmaceutical Research Saarland (HIPS) and heads the Department of “Microbial Natural Products” (MINS).

Professor Müller, the HIPS has set itself the goal of combining pharmaceutical research and research into infectious diseases, why is that important?

The number of dangerous pathogens is increasing globally. But the problem is certainly not just limited to developing countries, as the increasing incidence of multidrug-resistant tuberculosis clearly shows. Neither must the significance of infectious diseases here in Germany be underestimated. With more and more organisms developing resistances to available antibiotics, there are simply not enough new active agents currently under development. Our parent organization, the Helmholtz Centre for Infection Research (HZI) in Braunschweig, has extensive expertise in the field of infection research. However, until recently there was a lack of pharmaceutical know-how to drive forward the development of new drugs. The key motivation behind the creation of the HIPS was therefore to combine the skills and knowledge at the HZI and Saarland University so that both institutions could work together to develop new anti-infective strategies and agents.

Why was the Saarland chosen as the location for the new Institute?

Saarland University has an excellent reputation for pharmaceutical research, covering areas such as medicinal chemistry, pharmaceutical technology, pharmaceutical biology as well as pharmacology and toxicology. Much of the work involves natural products – and about 80 percent of anti-infectives currently in clinical use are based on natural products. Personal ties to the HZI certainly also played a role. I myself spent almost eight years at the HZI in Braunschweig before I took up an endowed professorship at Saarland University in the area of pharmaceutical biotechnology in 2003.

The HIPS was established jointly by Saarland University and the Helmholtz Centre for Infection Research. Founding the new Institute must have required close collaboration between Braunschweig and Saarbrücken.

Yes, that’s right, but despite their relatively large geographical separation, collaboration was excellent right from the start. And I’d like to take this opportunity to thank all those involved at the HZI, particularly the late Jürgen Wehland, and



at Saarland University. The state government here in the Saarland has also given us outstanding support, for example by providing the funding for the new HIPS building. We are very pleased to see that establishing Saarbrücken as a major centre of pharmaceutical research has received such strong political backing. It is also nice to see that the work we do is now getting positive feedback from a very broad political base at both the regional and national levels.

Regular events such as the HIPS Symposium and the HIPS Talks are also helping to raise public awareness of the HIPS and what it does.

The HIPS Talks are well attended and we've been able to invite some very distinguished speakers. The HIPS Symposium is generally held at the same time as the meeting of our Scientific Advisory Board (SAB). The SAB is made up of world renowned scientists, who also make excellent speakers at the symposium. The SAB has been established to support, advise and supervise the scientific and organizational development of the Institute and regularly meets in Saarbrücken to discuss current progress.

HIPS was established in 2009. What are some of your successes to date?

We have already made a substantial contribution to drug discovery and drug development. Researchers from around the globe have been attracted to the Saarland and part of this work has involved establishing some new and innovative technologies. We have also been very successful in mentoring young research scientists to become future leaders in industry and academia. Our research is published in a range of highly respected academic journals, including *Angewandte Chemie*, *Journal of the American Chemical Society*, *Proceedings of the National Academy of Sciences USA*, *Chemistry & Biology* and also in various *Nature*

Journals. We have additionally acquired substantial amounts of external research funding from funding providers such as the German Federal Ministry of Education and Research (BMBF), the German Research Foundation (DFG), the European Union (EU) as well as through collaborative projects with a variety of industrial partners.

The plan is for the HIPS to relocate to its new building on the Saarland University campus in 2015. By then the number of employees working at the HIPS will have grown to 150. What's going to be happening over the next few years?

We plan to set up a third and possibly a fourth independent junior research group. One of them will be funded by the German Centre for Infection Research (DZIF). In addition, my colleagues Professor Lehr and Professor Hartmann and I will soon be working predominantly for the Helmholtz-Institute once our three professorial positions in pharmaceutical science at Saarland University have been filled. Taken together, the HIPS and Saarland University will then be one of the largest centres of pharmaceutical research in Germany – a very pleasing result for all of us who have been involved in this exciting project.

Contact and more information

Helmholtz-Institute for Pharmaceutical Research Saarland (HIPS) | Campus UdS, Building C2.3
D-66123 Saarbrücken | Germany
info.hips@helmholtz-hzi.de | Tel. +49 (0)681 302 70200
www.helmholtz-hzi.de/hips



Executive Director

Prof. Dr. Ulrich Kalinke**TWINCORE**Zentrum für Experimentelle
und Klinische Infektionsforschung

TWINCORE, Centre for Experimental and Clinical Infection Research GmbH

TWINCORE, THE TRANSLATION CENTRE OF HZI AND MHH

TWINCORE, Centre for Experimental and Clinical Infection Research GmbH (TWINCORE) is a joint venture between the Helmholtz Centre for Infection Research (HZI), Braunschweig, and the Hannover Medical School (MHH). TWINCORE was founded in 2008 to enhance the cooperation between MHH and HZI and to perform infection research towards the improvement of prevention, diagnosis and therapy of human infectious diseases. At TWINCORE multidisciplinary research teams are established comprising clinical and basic researchers. At TWINCORE translational research strives to channel knowledge arising from basic research into clinical practice, and also to translate clinical observations into an improved understanding of disease mechanisms. TWINCORE holds laboratories and an animal unit which are adapted to conduct experiments up to bio-safety level S3**. A lively scientific programme is firmly established. In addition to the annual TWINCORE Symposium several different lectures are given, in which translational and basic researchers report on their work. Important lectures at TWINCORE and HZI are transmitted by a video conference system to the partners. At TWINCORE research is pursued in the following four research areas:



The TWINCORE research centre *TWINCORE*

1. ANALYSIS OF PATHOGEN-HOST INTERACTIONS

During long periods of co-evolution, pathogens and hosts developed a balance enabling survival of the host population as well as of the pathogen. At the cellular level intrinsic immune mechanisms control the pathogen. At TWINCORE the impact of such mechanisms on host- and tissue-specificity of pathogens is being studied. Since several years it is acknowledged that in addition to the recognition of “foreign” the communication of pathogen associated “danger signals” via pattern recognition receptors (PRR) plays a central role in the induction of protective immunity. The analysis of how innate immunity is triggered by pathogens and the consequences on pathogen-specific immunity are the subject of intensive investigations. In this process both acute and chronic courses of infections and associated inflammatory reactions are being examined. Pathogens developed various strategies to evade host immunity. Such strategies are being analysed in order to learn more about relevant immune mechanisms. Furthermore, the influence of regulatory cells on the course of infections is being studied.

2. NEW MECHANISMS OF PATHOGEN INHIBITION

Following the triumphant march of antibiotics in the treatment of bacterial infections, over the past decades key breakthroughs have been achieved in the development of antiviral substances. New approaches to inhibit pathogen reproduction are sought at TWINCORE. In collaboration with the HZI and the University of Hannover, biological compound libraries are being examined for antiviral and antibacterial substances. This involves the utilisation of new cell culture methods, for example permitting a targeted search for inhibitors of HCV replication or of inhibitors of bacterial biofilm formation. Similarly, new gene-therapy approaches are also being studied for the treatment of infectious diseases.

3. NEW VACCINATION STRATEGIES

Although vaccines were instrumental in the eradication or control of many different pathogens, there are still numerous infectious diseases for which no vaccine is available. Consequently, at TWINCORE new vaccination strategies are being developed. Virus-like particles are tested as vaccine vectors and strategies are developed for specific in vivo charging of specialized cross-presenting dendritic cells with antigen. One interesting experimental option



Director of Experimental Infection Research

Prof. Dr. Ulrich Kalinke | ulrich.kalinke@twincore.de

Director of Experimental Virology

Prof. Dr. Thomas Pietschmann | thomas.pietschmann@twincore.de

Director of Infection Immunology

Prof. Dr. Tim Sparwasser | tim.sparwasser@twincore.de

Director of Molecular Bacteriology

Prof. Dr. Susanne Häußler | sus@helmholtz-hzi.de

Head of Cell and Gene Therapy

Prof. Dr. Michael Ott | michael.ott@twincore.de

is the reinforcement of immune responses by influencing regulatory T cells. There are currently comparatively few approved adjuvants for the enhancement of immune responses following vaccination. Therefore, new adjuvants are being investigated in collaboration with partners from pharmaceutical industry as well as at HZI.

4. NEW PRECLINICAL MODELS

New therapeutic or prophylactic approaches developed in basic research need to be extensively tested in preclinical settings prior to first in human testing. At TWINCORE new models are being developed to better predict efficacy and potential adverse effects in humans. An important point in this respect is the humanisation of mice. To this end, immunocompromised mice are treated with human cells to allow components of the human immune system or of the human liver to develop in the animals. A further aspect is the genetic humanisation of mice, for example by bacterial artificial chromosome (BAC)-mediated transgenesis. Using this method, human receptors and allelic forms of them found in the human population may be expressed in order to investigate their functions in an animal model. A further aspect is the investigation of effects that are mediated by constant portions of human antibodies. This subject is particularly relevant in the context of the development of new therapeutic monoclonal antibodies. In addition to human peripheral blood mononuclear cells (PBMC) tonsil derived mononuclear cells (TMC) and organotropic tonsil slice cultures are being tested.

STRATEGIC CONSIDERATIONS TO FURTHER DEVELOP TRANSLATIONAL INFECTION RESEARCH AT TWINCORE / HZI

In the past years TWINCORE became an important partner in many local research consortia which are pursued together with co-workers of the HZI and/or the MHH and other institutions. One important focus was and still is the establishment of collaborations with clinical partners. This was done by setting up joint research projects based on clinical observations and practical needs. Well established and impressively documented by the scientific output is the collaboration between TWINCORE and the Clinic for Gastroenterology, Hepatology and Endocrinology. More recently, intensive collaborations were initiated also together with the Clinic for Immunology and Rheumatology, the Clinic for Pneumology and the Clinic for Newborns and Pediatric Pneumology, Allergology and Neonatology and other partners of MHH. TWINNING-projects between physician scientists and basic researchers turned out to be particularly effective. Such formats are based on 1-2 years of clinical leave to be spent at TWINCORE, after which candidates are well trained in order to proceed with a combined research and clinical career. So far two such positions have successfully been filled and it will be a matter of discussion how this format can be further developed in the future.

The Programme Infection Research of HZI offers a multitude of different opportunities to expand into collaborations with clinicians and thus to address translational questions which so far have not easily been accessible. In particular in the Cross-Topic Foci „Biofilm Research“ and „Chronic Virus Infections“ joint activities have been established in the past. Furthermore, the Cross-Topic Focus „Vaccine Research“ is attractive on the one hand to develop immunomonitoring together with experts of the MHH and on the other hand to study vaccine induced immune responses in the context of the Helmholtz initiative for Personalized Medicine (iMed). Research involving patient materials offers the opportunity to identify new biomarkers which can have a direct impact on the daily clinical practice and eventually may help to pave the way towards the establishment of individualized infection medicine. The new Clinical Research Centre initiated together by HZI, MHH and the Fraunhofer Institute for Toxicology and Experimental Medicine (ITEM) will start operations in 2014. This centre will allow the performance of early clinical trials to test e.g. new vaccine formulations and new vaccine

candidates. On the long run even in-house developments such as new natural compounds with anti-microbial activity might be tested at CRC.

The recently identified research field „Infection and non-communicable diseases“ offers additional interaction opportunities. Of particular interest will be the development of projects in the areas of „Infection and Cancer“, „Infection and Neurodegeneration“, „Infection and Metabolic Dysfunction“ and „Infection and Cardiovascular Diseases“. In these priority areas single projects have already been initiated, mainly together with partners of the Helmholtz Association, and as already done in the field of „Infection and Neurodegeneration“ new consortia together with clinical partners can be established.

Considering this plethora of new opportunities in the field of translational infection research, it will be of primordial importance (i) to involve the right partners from HZI, MHH and TWINCORE, (ii) to establish appropriate boards comprising delegates from all three institutions to prioritize questions regularly, and (iii) to identify new challenges in infection research in order to efficiently develop an innovative and focused research portfolio.

RESEARCH GROUPS AT TWINCORE

Currently four W3 professorships are established at TWINCORE. In context of the 2012 recruitment initiative of excellent female scientists of the Helmholtz Association, Prof. Dr. Susanne Häußler was appointed to a W3 professorship at the Hannover Medical School. Furthermore, after a successful evaluation, and to ward off another appointment, Prof. Dr. Thomas Pietschmann was offered a W3 professorship also at the Hannover Medical School. Thus, at TWINCORE currently there are working Prof. Kalinke as Executive Director of TWINCORE and Director of the Institute for Experimental Infection Research, Prof. Pietschmann as Director of the Institute for Experimental Virology, Prof. Sparwasser as Director of the Institute for Infection Immunology, and Prof. Häußler as Director of the Institute for Molecular Bacteriology. Furthermore, the Research Group for Cell and Gene Therapy headed by Prof. Ott of the Clinic for Gastroenterology, Hepatology and Endocrinology of the MHH, directed by Prof. Manns, has been delegated to TWINCORE. As of May 2013 a total of 147 employees are working at TWINCORE.

RESEARCH GROUP PROF. KALINKE

Following viral infection, usually within hours type I interferon responses are induced, which secure the initial survival of the host. It is approximately a week later that adaptive immunity is activated to an extent that it is able to eradicate pathogens. In earlier projects we have shown that following an infection with the vesicular stomatitis virus (VSV) a small number of highly specialised cells, also addressed as plasmacytoid dendritic cells (pDC), are activated via PRR triggering to produce large quantities of protective type I interferon. Interestingly, practically all viruses examined more closely developed countermeasures that inhibit the induction of such type I interferon responses. A key focus of our work is to study how different viruses induce type I interferon responses and which type I interferon-inhibiting factors they encode. Local conditions of type I interferon responses decisively influence the course of disease. In that line we are investigating how type I interferon inhibits the spread of pathogens within the central nervous system. In more recent investigations we discovered that type I interferon can also have direct effects on immune cell functions. Antibodies are comparatively large molecules, the variable parts of which bind antigens specifically, whereas the constant parts may be bound via so-called Fc receptors expressed by certain immune cells and other body cells and confer antibody function. We investigate how Fc receptors interact with



The workgroup of Prof. Dr. Kalinke



Prof. Dr. Ulrich Kalinke

different subclasses of IgG antibodies and which immune functions are influenced this way. This issue is particularly relevant for therapeutically-employed monoclonal antibodies because such reagents play an increasingly important role as innovative therapeutic agents in the treatment of tumours, autoimmune diseases and infections.



Elena Grabski at the centrifuge TWINCORE

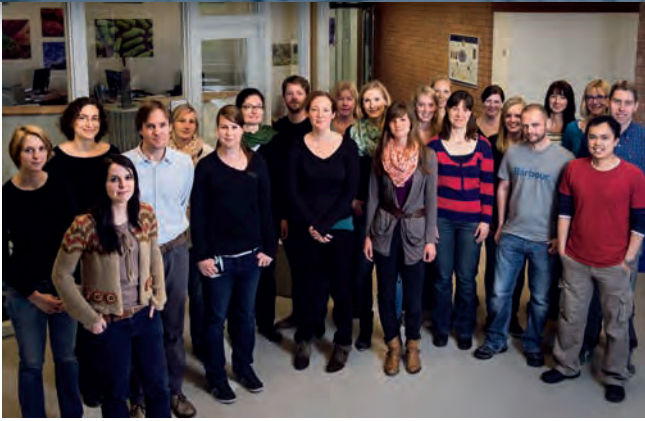

The workgroup of Prof. Dr. Pietschmann



Prof. Dr. Thomas Pietschmann

RESEARCH GROUP PROF. PIETSCHMANN

Infection with HCV, which belongs to the family of flaviviruses, is one of the major causes of chronic liver disease. According to WHO estimates, up to 170 million people have had HCV contact worldwide. Of these, around 100 to 130 million people are considered to be chronically infected. We develop new cell culture techniques for the investigation of HCV replication. The goal of this research is to investigate the molecular mechanisms of HCV replication in liver cells. In particular, early stages of HCV infection are studied, which are critically involved in virus entry into liver cells. We are also analysing processes that lead to the packing of the viral genetic material in progeny viruses and their release from the host cell. In this manner we aim to draw up the fundamental basis of the infection strategy of this human-pathogenic virus in order to subsequently generate new approaches and perspectives for the develop-

ment of therapies. In TWINNING projects with partners at the MHH and the HZI we employ the HCV cell culture system to identify new agents that inhibit HCV replication. Furthermore, within the Helmholtz Alliance on Immunotherapy of Cancer we are involved in the development of a new immunotherapy approach for the treatment of chronic HCV infection and HCV-associated hepatocellular carcinoma. A new focus is forming our investigations of the HCV species and tissue tropism. HCV replicates in the liver and only infects humans and chimpanzees. The mechanisms which are responsible for this restricted species and tissue tropism have been scarcely studied up to now and thus are only barely understood. With our research on this topic we aim to understand how extra hepatic virus reservoirs can affect virus pathogenesis and the response to therapy, how HCV makes use of essential cellular cofactors and which host factors control the HCV replication.



Discussion on results of experiments within the work group of Prof. Dr. Pietschmann. From left to right: Dr. Christiane Brohm, Dr. Sibylle Haid, Dr. Julia Bitzegeio, Dr. Eike Steinmann, Prof. Dr. Thomas Pietschmann | TWINCORE

RESEARCH GROUP PROF. SPARWASSER

Our focus lies upon the investigation of the significance of PRR, for example from the family of *Toll-like* receptors (TLRs) and the C-type lectins for the activation of the most important positive regulators of the immune system and initiators of adaptive immunity, *i.e.* the dendritic cell system (DCs). A further focus is upon regulatory T cells (Tregs), which may be regarded as the principal counterparts to DCs: Tregs use mechanisms as yet not completely understood to inhibit an overshooting immune response and limit the proliferation of T effector cells. Optimal vaccination strategies against pathogens may comprise the activation of specific DC subpopulations whilst avoiding Treg expansion or induction. Vaccination studies aimed towards Tregs and DCs in the murine model system have several limitations, one of which is that *in vivo* analysis of Tregs and DC subpopulations is extremely difficult. For example, subpopulations of DCs exist in extremely low numbers in various lymphatic organs that have highly specialised tasks in several cases, including the induction of tolerance. As these “*regulatory immune cells*” usually react highly sensitive to *ex vivo* isolation and have thus far proved only inadequately manipulable *in vivo*, the knowledge of function and significance of Tregs and DC subpopulations for adaptive immunity remains incomplete. A further complicating factor is the expression of different pattern recognition molecules or different expression profiles of PRRs to DC subpopulations between humans and mice. A key objective is therefore the development of molecular tools that allow the genetic manipulation of DCs and Tregs. We wish to use



The workgroup of Prof. Dr. Sparwasser



Prof. Dr. Tim Sparwasser

these models to investigate the function of Tregs and subpopulations of DCs in infection, allergy and tolerance. In “*humanised*” models the role of PRRs such as human TLR9 and DC-SIGN is analysed and vaccination strategies aimed at these molecules tested *in vivo*. Within the Sparwasser Institute Dr. Matthias Lochner is currently establishing a junior research team on the analysis of the role of DCs in the induction and control of inflammatory (Th17) and regulatory T cell populations in infection and inflammation reaction of the intestine.



Wiebke Ginter pipetting samples | TWINCORE



Abdul Mannan Baru and Catharina Schrauf-Arnold demonstrating experimental procedures | TWINCORE



Prof. Häußler and her team discussing experimental results | TWINCORE



The workgroup of Prof. Dr. Häußler



Prof. Dr. Susanne Häußler

RESEARCH GROUP PROF. HÄUSSLER

The success of modern medicine is increasingly affected by opportunistic bacterial infections. In chronic bacterial infections the pathogens may often come together within so-called biofilms, and are then better protected against attack by cells of the immune system or antibiotics. The life within the population of the bacteria also provides additional adaptation mechanisms to stress situations that go beyond the usual reactions of individual cells. *Pseudomonas aeruginosa* is the most dominant bacterial pathogen causing chronic lung infection in cystic fibrosis (CF) patients. Although most patients are colonised with only one *P. aeruginosa* clone, various morphotypes can often be isolated. This diversity seems to play an important role in the persistence of the germ and thus in the formation of a chronic infection. Our research focuses on the elucidation of the molecular mechanism underlying this diversity. In CF patients with a chronic *P. aeruginosa* infection of the lungs so-called small colony variants (SCVs) are frequently found, which form biofilms particularly efficiently. To identify the mutations that lead to the formation of such SCVs, we sequenced the genomes of *P. aeruginosa* clinical isolates using the so-called next generation sequencing technology.

The comparative analysis of chromosomal DNA sequence of *P. aeruginosa* isolates with similar phenotypic characteristics; we look for typical base substitutions and check whether they are causally involved in the progression of the phenotype.

In the future we aim to study clinically relevant mutations that occur in *P. aeruginosa* under *in vitro* biofilm growth conditions and *in vivo* in the course of a chronic infection. The knowledge of the genotypes that are selected at different stages of infection can be helpful for the development of new, promising therapy strategies. In addition to two well-characterized homoserine lactone signal molecules *P. aeruginosa* produces a third interbacterial signal molecule, the Pseudomonas quinolone signal (PQS). PQS is involved in cell density dependent virulence factor regulation – as well as the homoserine lactone – and is essentially involved in the establishment of *P. aeruginosa* biofilms. However, the molecular mechanism of the implementation of the PQS signal in a bacterial behaviour at the signal cell level is largely unknown. Here, a *pqsE* encoded enzyme, the last gene in the PQS biosynthetic operon, seems to play a central role. The elucidation of the function of PqsE is a key research focus of our group.

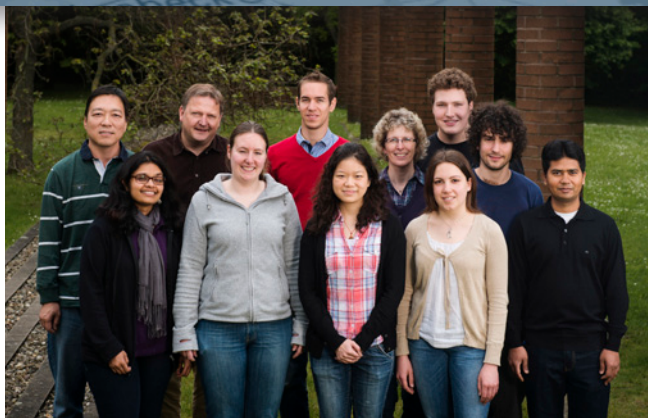

The workgroup of Prof. Dr. Ott



Prof. Dr. Michael Ott

RESEARCH GROUP PROF. OTT

We develop cell and gene therapy procedures for the treatment of hereditary liver disease. Another focus lies on the development of mouse models with chimeric human/murine liver tissue and human immune system for researching vaccination strategies against HIV and HCV. The repopulation of the liver with human liver cells and the transplantation of human blood stem cells into immune deficient mice continue to represent a major scientific challenge. In order to investigate vaccination strategies in the alb-uPA transgene immune deficient (RAGyc) mouse it is necessary that human cells of a donor are utilised in the repopulation of the mice. Where primary tissue is used as starting material the isolation of both cell populations using foetal liver tissue exclusively is possible. In our transplantation experiments it emerged that the transplantation of foetal hepatoblasts is significantly less efficient than that of adult primary hepatocytes. Alternatively, the research group enabled the transplantation of foetal

human liver tissue beneath the capsule of the recipient liver to be tested for the first time. The first combined transplantations of human blood stem cells and foetal liver tissue to a newly-developed mouse strain are set to be performed shortly. Due to the lack of availability of primary human cell material for the “humanisation” of mice, as well as for cellular therapies in humans, the research group is conducting intensive research into alternative cell sources. In association with other MHH groups and international partners, research is underway into hepatic differentiation protocols for embryonic stem cells and iPS cells. In another project the risk of insertional mutagenesis in lentiviral gene transfer is being analysed. Serial transplantation of *ex vivo* genetically transduced hepatocytes enables the incidence of liver tumours in dependence on the number of lentiviral insertions to be investigated. Furthermore, the research group is supervising a clinical study on cell transplantation in patients with urea cycle disorder. This project marks the world’s first controlled study on cell therapy of hereditary metabolic diseases of the liver.



Prof. Ott and his team observing results from an experiment (from left to right): Asha Balakrishnan, Viola Stückemann, Michael Ott, Qinggong Yuan, Sabine Brandes, Felix Kollenda, Martin Pacher | TWINCORE

TWINCORE PUBLICATIONS

In 2011 employees working at TWINCORE published a total of 70 articles whereas in 2012 the total number of published articles amounted at 73. In 2013 already 75 articles have either been published or are “in press” (see “Complete list of articles published in 2011, 2012 as well as articles published and “in press” in 2013 by employees working at TWINCORE”).

Contact and more information

TWINCORE | Zentrum für Experimentelle und Klinische Infektionsforschung GmbH
 Feodor-Lynen-Str. 7 | D-30625 Hannover | Germany
 Tel. +49 (0)511 220027-0
twincore@twincore.de | www.twincore.de/en/



Dr. Timo Jäger

Managing Director of the
German Centre for Infection
Research (DZIF)
timo.jaeger@dzif.de



The German Centre for Infection Research (DZIF)

Seventy years after the onset of the antibiotic era, infectious diseases continue to be among the strongest contributors to morbidity and mortality worldwide. The Grand Challenges in infection research are caused by emerging and globally present pathogens, rapid development of resistance against anti-infectives and poverty-associated infectious diseases in developing countries. In addition, health care-associated infections challenge human health in industrialized societies, and immuno-suppression after transplantation or by state-of-the-art medical treatment of cancers paves the way for complicated infections.

These Grand Challenges can only be met by an integrative effort bundling the scientific expertise in basic research, epidemiology, translational research and clinical studies. In Germany, such expertise in infectious diseases is dispersed throughout the country, translational efforts are scarce and efforts tackling the Grand Challenges are fragmented and inefficient. The Federal Ministry of Education and Research (BMBF) founded the Deutsches Zentrum für

Infektionsforschung (DZIF) as an integrated multi-centre structure bringing together selected universities, university hospitals and non-university research institutes and linking together their strong research portfolios as well as clinical infrastructures. The DZIF will foster the strategic coordination of concerted translational efforts aiming at novel diagnostic, preventive and therapeutic measures against the most important infectious diseases.



Members of the General Assembly of DZIF | DZIF



Map of the regional units of DZIF with their logos | DZIF

DZIF'S MISSION: TRANSLATIONAL RESEARCH

The DZIF will coordinate and strategically align translational infection research. Translational research means that results of basic research should systematically be developed further and should make new diagnostic, preventative and therapeutic methods for infectious disease treatment available. In return, the clinical staffs' knowledge about infectious diseases and the interests of patients will elucidate basic researchers' work. In total, translational research aims for effective interactions between basic and clinical research to benefit from each other.

In defined thematic units, DZIF researchers from different institutions work on specific pathogens and infectious diseases. Thus, DZIF members already achieved tremendous synergetic effects by. Indeed, this network of experts led to a pipeline with over 30 drug and vaccine candidates, which would not have arisen without the DZIF financial support and the combined know-how. For the first time, there is a real chance to implement these candidates on the market in the future.

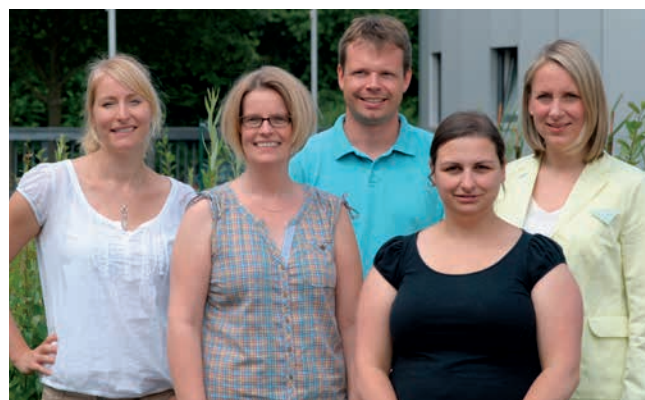

The administrative group at the main office in Braunschweig (from left to right): Simone Friedrich, Dr. Jennifer Schmitz, Dr. Timo Jäger, Dr. Vivien Nagy, Janna Schmidt | DZIF



The Executive Board of the German Centre for Infection Research at the Opening Ceremony in December 2012 in Berlin (from left to right: Prof. Dirk Heinz, Prof. Ulrike Protzer, Prof. Martin Krönke) | DZIF

The Research Areas: Thematic Translational Units

EMERGING INFECTIONS

Outbreaks of emerging pathogens appear suddenly and a rapid response is crucial to contain the spread of the disease. Actions must be taken both to raise the awareness of the public health sector and to develop strategies to speed up biomedical research and production of candidate vaccines and therapeutics. The mission of the Thematic Translational Unit Emerging Infections is to establish a research infrastructure that contributes to rapid containment of emerging infections and to mitigate the consequences of such outbreaks for the public. To fulfil this mission, the Thematic Translational Unit Emerging Infections shall link expert individuals and research groups within three areas covering the entire response chain: i. pathogen detection, diagnostics and clinical management; ii. emergency vaccines; iii. broad-range antivirals.

TUBERCULOSIS

Despite enormous efforts tuberculosis (TB) remains a prime global health threat, with at least 8 million newly infected individuals and 1.4 million deaths every year. The problem is compounded by HIV/TB co-infections and the emergence of multi- and extensively drug-resistant (MDR and XDR) strains of the *Mycobacterium tuberculosis* complex, particularly in Eastern Europe, Sub-Saharan Africa and Asia. TB control, on the global level, is faced

with several challenges: There is currently no vaccine that efficiently protects against pulmonary TB in adults; the arsenal of anti-TB drugs is limited and there are only few new drugs in industrial pipelines; biomarkers to predict or monitor treatment success are virtually absent; and access to TB diagnostics is restricted in resource-poor settings. The mission of the Thematic Translational Unit Tuberculosis is to improve TB infection control, with a focus on M/XDR-TB.

MALARIA

Despite a multitude of actions taken to eradicate malaria, the disease still remains one of the top killers of African children under 5 years of age. An efficient vaccine for prevention has not been brought to the market yet, and the spread of resistance to the drugs currently administered makes it painfully clear that we need new medications to provide effective therapies for all target groups. Regional differences in parasite and human populations as well as co-infections are further obstacles impeding an efficient and correct treatment of patients. A continuous effort in epidemiological research is required to keep knowledge of current parasite distributions up-to-date as a prerequisite for efficient intervention design. The mission of the Thematic Translational Unit Malaria is to fight malaria with preventive and therapeutic measures using disease modelling to optimise interventions in Africa.



Researchers at TTU "Malaria" in Tübingen are making significant headway in finding a vaccine against malaria.
© DZIF/scienceRELATIONS.de

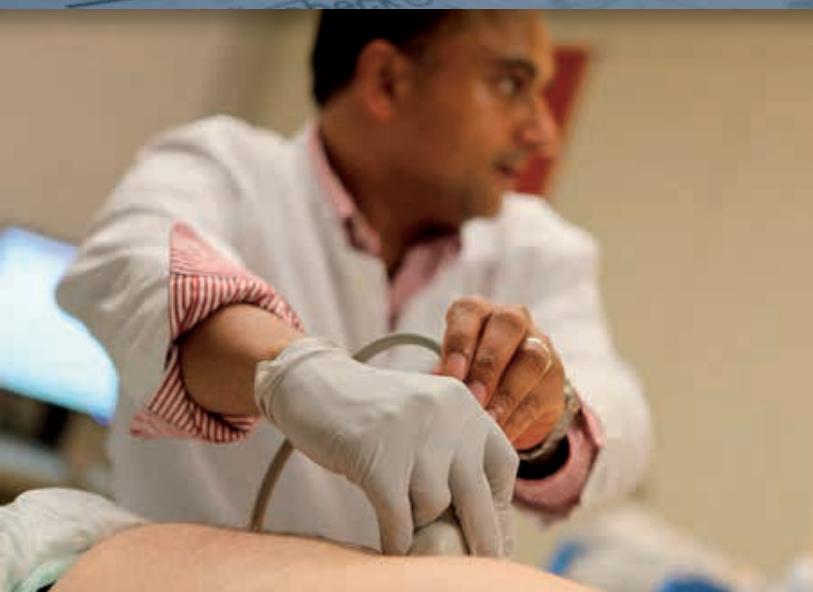

Sonography for hepatitis diagnosis. | © DZIF/scienceRELATIONS.de

HEPATITIS

Worldwide, more than half a billion people are chronically infected with the hepatitis B (HBV), C (HCV) and/or D virus (HDV) and are at high risk of developing end-stage liver disease and hepatocellular carcinoma. A preventive vaccine and efficient antiviral drugs are available for HBV. However, current treatments merely suppress viral replication and no curative treatments are in the pipeline. For HCV, on the other hand, the first specific direct-acting antivirals (DAAs) have been approved and other promising compounds are in clinical development.

With an increasing number of therapeutic options and the emergence of viral resistance, therapy will become much more complex in the coming years. There is an urgent need to establish treatment standards that consider all patient groups including in particular the difficult-to-treat patients, *e.g.* those with end-stage liver disease who are excluded from most clinical trials. Finally, specific treatments are lacking for certain forms of chronic viral hepatitis such as HDV/HBV co-infection, the most severe form of the disease.

GASTROINTESTINAL INFECTIONS

Gastrointestinal infections kill around three million people globally each year. Diarrheal infections are responsible for approximately 2.5 million deaths per year (4.3 % of all deaths, and 10 % of deaths in children up to four years; WHO 2011). The most important gastrointestinal (GI) pathogens that cause acute diarrhea include *Campylobacter*

jejuni/coli, *Salmonella*, *Shigella*, *Escherichia coli*, *Yersinia enterocolitica*, *Vibrio cholerae*, *Clostridium difficile*, rotaviruses, noroviruses, and *Entamoeba histolytica*. In addition to the diarrheal pathogens, one of the most important GI pathogens is *Helicobacter pylori*. Approximately half the world population is infected with this pathogen which is the main cause for gastric cancer. No effective vaccines are available for any of the leading GI pathogens and treatment options are unsatisfactory for most of them. Thus, there is an urgent need for novel vaccines and therapeutic interventions.

The mission of the Thematic Translational Unit Gastrointestinal Infections is to improve the diagnosis, treatment and prophylaxis of bacterial gastrointestinal infections, and thereby aims at reducing the morbidity and mortality from these diseases. Uniquely, all interventions developed will be selective for specific pathogens or groups of them, rather than broadly attacking pathogens and commensals alike. Another important research focus is to develop therapies that protect the microbiota during interventions against GI pathogens.

INFECTIONS OF THE IMMUNOCOMPROMISED HOST

As a consequence of our aging population and the growing prevalence of chronic diseases, infections in patients with immunodeficiencies are a serious issue in clinical practice. Furthermore, temporary or in many cases even long-term alterations of immune functions must be factored into the development of new therapies in modern medicine, *e.g.* organ transplantation or cancer treatment. In immunocompromised patients microbes that are normally efficiently controlled by a healthy immune system can suddenly become life-threatening pathogens that are difficult to treat with currently available anti-infectives. Risk stratification to identify clinically relevant immunodeficiencies and associated pathogens is still highly limited.



In clinics such as the University Hospital of Cologne, nasal swabs are currently being taken from every patient to test for MRSA germs. | © DZIF/scienceRELATIONS.de

However, since immune alteration is a major contributor to disease in immunocompromised patients, active and passive immunotherapies as well as immune modulation provide promising options for the development of novel and highly effective anti-infective therapies.

HEALTHCARE-ASSOCIATED AND ANTIBIOTIC-RESISTANT BACTERIAL INFECTIONS

A phenomenal increase in infections caused by antibiotic-resistant bacterial pathogens has become one of the biggest public health concerns over the last ten years. Most severe cases result from healthcare-associated bacterial infections which are increasingly caused by methicillin-resistant *Staphylococcus aureus* and extended-spectrum beta lactamase (ESBL)-producing enterobacteria. Unfortunately, most pharmaceutical companies have shifted their R&D activities towards chronic infections and diseases and only very few new compounds are expected to become available in the next decade. The Thematic Translational Unit Healthcare-Associated and Antibiotic-Resistant Bacterial Infections will support translational research to develop novel anti-infective strategies. It will also foster the establishment of clinical studies to assess the suitability of improved infection control measures and appropriate use of antibiotics (e.g. antibiotic stewardship) for reducing the

burden of healthcare-associated and antibiotic-resistant bacterial infections.

NOVEL ANTI-INFECTIVES

Antibiotics have improved the life expectancy of mankind. However, multi-drug resistance has become common place in pathogenic bacteria and our “magic bullets” are losing their efficacy. Current medical standards in infectious disease management, intensive care and transplantation medicine rely heavily on efficacious classical anti-infective chemotherapeutics, yet the antibacterial development pipeline is drying up and the number of innovative drugs reaching the market is dwindling rapidly. In spite of the strong medical need, the economic viability of antibiotic R&D programmes is being questioned and the interest of the private sector is waning. R&D is increasingly dependent on the biotech sector which, due to financial limitations, focuses on single small-scale and short-term projects. The absence of strong industrial commitments reflects back onto the academic sector and provides little incentive for either researchers or institutions to invest in translational activities. The mission of the Thematic Translational Unit Novel Anti-Infectives is to bridge the gap between basic research and current anti-infective development activities.

DZIF infrastructures: From bench to bedside

The DZIF mission is to coordinate and strategically align translational infection research. Basic research should result in new diagnostic, preventative, and therapeutic methods for treatment of infectious diseases. Therefore, a modern infrastructure is essential – from the laboratory through clinics and pharmaceutical companies to patients.

PRODUCT DEVELOPMENT UNIT

From target discovery to approval of new drugs, 95% or more get stuck in the ‘valley of death’ and fail to reach clinical phase. All too often, this is not because of shortcomings with the innovative product, but rather due to an inadequate translational development process. The mission of the Product Development Unit (PDU) is to bridge the translational gap and to catalyse and regulate the rapid transformation of research discoveries into products including their preclinical development, manufacture and initiation of a first-in-man clinical trial.

CLINICAL TRIAL UNIT

In 2011, the DZIF’s respective sites already had excellent clinical trials units (CTUs), yet their activities were restricted to a narrow spectrum of indications. The CTUs rarely reflected the full range of diseases the DZIF is dedicated to. However, the potential weakness of this heterogeneity is counterbalanced by a particular strength of the DZIF: Its network combines expertise in all clinical infectious disease indications with direct access to these clinical trial units, albeit to a varying extent at each site.

Thus, the strategic plan for increasing the value of the DZIF CTU started with the exchange of expertise between sites. A central coordinating office supports a mutual strategy for clinical trial performance at the DZIF in accordance with BMBF Standard Operating Procedures.

The nationwide DZIF platform reduces the cost of conducting clinical trials by mobilizing an unprecedented recruitment potential. With high-level data quality and performance rates, the DZIF clinical trial structure aims to become the preferred partner for academic and industrial clinical trials.

AFRICAN PARTNER SITES

This infrastructure shall establish and strengthen a sustainable North-South collaboration with African institutions of infectious disease research. Long-lasting collaborations between some of these centers and DZIF partners already exist. Yet, most of these sites run on a project basis leaving few resources for sustainable investments. Working together with these partner sites is crucial since most of the diseases endemic to these sites are also an issue in developed countries, albeit at much lower frequencies.

The DZIF intends to reinforce the networking between the existing collaborations. The goal is to improve and harmonize the link between DZIF partner sites and selected African research sites and to facilitate access to well-characterized clinical samples of specific interest.

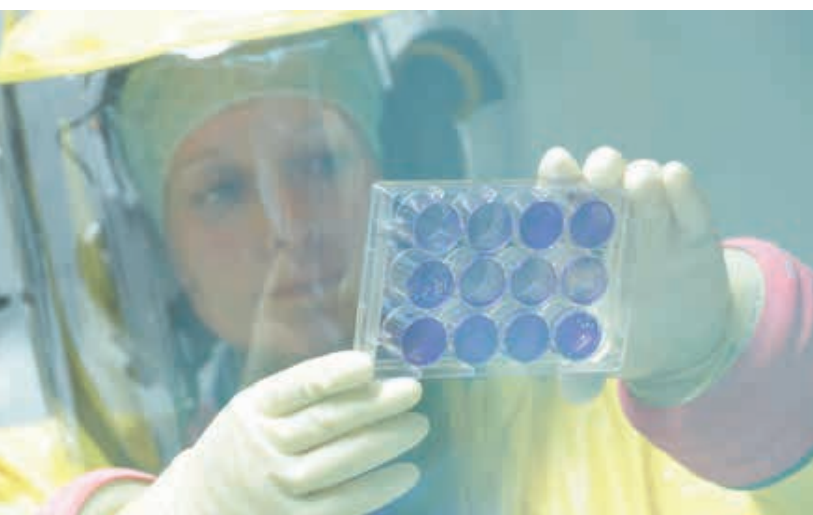

NATURAL COMPOUND LIBRARY

Numerous small molecule pharmaceuticals derived from natural microbial sources have been proven to play a key role in combatting infectious diseases. Such compounds account for the vast majority of antibiotics currently on the market. A particular shortcoming of drug discovery in recent decades is that only a small share of the currently known bacteria or fungi have been explored for their potential to produce novel drug leads. Furthermore, no state-of-the-art molecular biological methods have yet been systematically applied to screen the potential of microbial producers.

The DZIF Natural Compound Library will be combining isolation methods for obtaining and pre-selecting hitherto unexplored “creative” organisms and functional genomics with systems biology approaches, fermentation optimization, assay development, and bioprofiling in order to establish and optimise a highly diverse chemical compound library. This will render natural products accessible for screening and ultimately enable subsequent compound development in different Thematic Translational Units.

BIOBANKING

Access to a comprehensive biobanking infrastructure is mandatory for multi-site infectious disease research and its translation into practical application. Biomaterials of interest to the DZIF include culture collections of infectious pathogens and microbial producers, liquid biological samples such as serum, plasma and urine, and characterized tissue samples from infected patients. A biobank coordination and technology platform will be established within this infrastructure with specific emphasis on an interactive platform as well as high level preanalytical and storage quality.

BIOINFORMATICS PLATFORM

Major technological advances during the last decade have resulted in massively decreased prices for DNA sequencing, while quality and information density have rapidly increased. These advancements will directly impact a multitude of research areas: investigation of host-pathogen interaction, genomic epidemiology, transcriptomics and regulatory networks, metagenomics, and the identification of epidemiologically distinct clones and their potential to develop into outbreak strains with extended pathogenic capabilities – all of those areas will benefit from these improvements.

Scientific interpretation of data will only be possible by efficient preprocessing and analysis of data. Systematic collation technologies will be required to deal not only with the huge quantity of data generated but also to deal with the heterogeneity of the formats involved. The challenge is to generate aggregated information that can be used for further scientific interpretation. The unit will establish and provide tools to supply access to new technologies for respective research areas. In parallel to data management, statistical analysis methodologies will be implemented to deal with multi-dimensional data. The integration and comparative analysis of data generated within the DZIF network is the basis for both interdisciplinary and translational research. Bridging the gap between established genome bioinformatics and the medical data from clinical research will represent the main challenge for the DZIF Bioinformatics Platform.

THE DZIF ACADEMY

Education and training of next generation talents are among the most rewarding investments to strengthen and develop infection research in Germany. The DZIF Academy aims at attracting young medical doctors and scientists into infection research by establishing innovative and highly attractive educational programmes for students and post-graduates and to train next generation clinician scientists. By exchange programmes, structured doctoral programmes and collaborative spring and autumn schools, the DZIF Academy reflects and emphasizes the synergistic nature of DZIF and shares its mission to close the gap between basic research and clinical development.

DZIF ORGANIZATION

DZIF partners are members of DZIF e.V. (eingetragener Verein, incorporated society) under German Law. The General Assembly and the Executive Board are mandatory bodies of the DZIF. Further bodies of the DZIF are the Commission of the Funding Authorities and the Scientific Advisory Board. The Administrative Office, located at the Campus of Helmholtz Centre for Infection Research, is responsible for managing and coordinating all research funding procedures and it organizes General Assembly meetings, reporting and review procedures.

Contact and more information

Deutsches Zentrum für Infektionsforschung e. V.
 German Centre for Infection Research
 Inhoffenstraße 7
 D-38124 Braunschweig
 Germany
info@dzif.de
www.dzif.de



Certain therapies, for instance bone marrow transplants, require the immune system of the patient (child) to be artificially suppressed. Even harmless infections can then become a threat. © DZIF/scienceRELATIONS.de



Prof. Dr. Rainer Jonas

Department of Scientific Information and Internationalization (WI)
rjo@helmholtz-hzi.de

Facts and Figures

In 1965 the HZI was founded as “Centre for Molecular Biological Research” (GMBF) with financial support by the Volkswagen Foundation. In 1976 the Federal Government through the Ministry for Research and Technology (BMFT) together with the State of Niedersachsen took over the Centre, now called “German Research Centre for Biotechnology” (GBF). Since then the BMFT/BMBF as well as the State of Niedersachsen have jointly financed the GBF/HZI. In 2006 it was the first research centre of the Helmholtz Association to change its name into a Helmholtz Centre institution: the Helmholtz Centre for Infection Research – HZI. In 2008, the TWINCORE was founded by the HZI and the Hannover Medical School as a centre for translational research, located in Hannover, and in 2009 the Helmholtz Institute for Pharmaceutical Research Saarland (HIPS) was founded to be a branch of the HZI at the Campus of the University of Saarland, Saarbrücken.

Financing

In 2012, the complete budget was 72 Mio € including 22 Mio € of external funding. Within the latter amount also the setting up of new building is included.

External Funding for Research

More than 75% of the external funding came from national research programmes. About 12% and 9% were from EU programmes and industry, respectively.

External Financing of Research (in T€)

Source	Full Cost
BMBF	4,669
DFG	3,473
EU	1,885
HGF	3,530
Industry	1,465
Others	537
Total Sum	15,559

External funding 2012 - by source

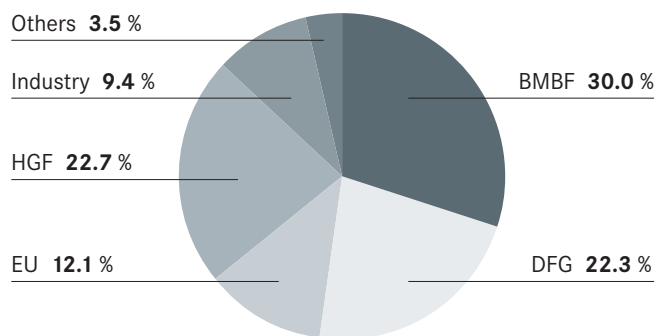

Patents, property rights and licences – year 2012

Priority based applications	4
Granted patents	55
Total number of held property rights	555
Licence agreements	55
Licence proceeds (T€)	6,164

Participation in relevant Research Networks

In 2012, the HZI participated in
 18 special DFG Programmes,
 3 ERC Starting Grants,
 19 EU projects (incl. ERC and COST Action),
 38 BMBF / BMWI projects (including 8 bilateral WTZ
 cooperation projects
 with Argentina, Brazil, Chile and India), and
 2 projects of the Swiss National Science Foundation (SNSF).

EU Frame Programmes	
CP	CASIMIR
CP	Sysgenet
CP-IP	FAST-XDR-DETECT
Cooperation	FLUINHIBIT
ERC Adv. Grant	BACSIN
ERC StG	RESISTOME
ERC StG	CMVAgSTIMULUS
ERC StG	EXPLOGEN
IMI	EMTRAIN
IMI	COMPACT
IMI	COMBACTE – Management
IMI	COMBACTE – KOM
IMI	COMBACTE – INI
IMI	COMBACTE – CPRO
IMI	COMBACTE – MOBA
IMI	COMBACTE – MINP
IMI	COMBACTE – MMIK
Infrastructures	INSTRUCT – associated
Infrastructures	INFRAFRONTIER 13
Infrastructures	EU-Openscreen – CO / - SU / - RT
Marie Curie IEF	Gasautophagy
Marie Curie CIG	SalmoVir
Marie Curie CIG	InflaComm
Marie Curie ITN	PathLooser_ITN
SME-targeted CP	Complex INC – RTD / - other

Graduate School

The HZI is actually participation in 4 international Graduate Schools, two financed by the State of Niedersachsen and one each by the DFG and HGF. This means that in 2012 229 PhD students were performing their PhD studies at the HZI.

BMBF	
	SB Labor DESY
Biotransporter	PeTra – DDEL
Biotransporter	PeTra – CMIK
Biotransporter	PeTra – VAC
BMBF Special action	Biofilm Inhibitors – MINS
BMBF Special action	Biofilm Inhibitors – MOLI
BMBF Special action	Biofilm Inhibitors – DDOP
BMBF Special action	Biofilm Inhibitors – MWIS
BMBF Special action	Biofilm Inhibitors – TWINCORE
BMBF Special action	Biofilm Inhibitors – CBIO
COMPACT support	Preparations IMI
eBio	CellSys
eBio	ImmunoQuant
eMed	SYSIMIT
ERA-Net	BIBA
ERA-Net	HCRus
ERA-Net	HCVAX
ERA-Net	LISTRESS
Excellence Research New Countries	“Taschentuchlabor”
IB BMBF Chile	Flavonoid Biotransformations
IB BMBF Chile	Metatranscriptomics
IB BMBF India	Validation of PARF Peptide
IB BMBF India	Streptococcal endocarditis 2
GerontoSys	GerontoSHIELD
KMU innovative	Dis-Z-Konjugate (MWIS)
KMU innovative	Dis-Z-Konjugate (MINS)
KMU innovative	FuDel
Medicinal Infection Genomic	LegioProtect
Medicinal Infection Genomic	MENAGE
National Cohort	National Cohort
Susceptibility & Resistance against Infections	PROGRESS
WTZ Ukraine (SciTechnolCoop)	Landrug
Zoonosis	FBI-Zoo II

Helmholtz Graduate School for Infection Research	HIGS
Helmholtz-Kolleg for Infection Biology	H-IRISIB
DFG-Graduate School GRK 653	“Pseudomonas”
DFG-Graduate School GRK 1273	“Chronical Infections”

DFG (German Research Foundation)	
SFB 599	Permanent Implantates (CMIK - D8)
SFB 599	Permanent Implantates (RDIF - D7)
SFB 599	Permanent Implantates (RDIF - D1)
SFB 599	Permanent Implantates (RDIF - DR11)
SFB 599	Permanent Implantates (RDIF - D8)
SFB 738	Optimization of Conventional and Innovative Transplants: Foxp3 T cells
SFB 738	Optimization of Conventional and Innovative Transplants: TP Z1 II
SFB 854	Molecular Organisation Cellular Communication in the Immune System - CPRO
SFB 854	Molecular Organisation Cellular Communication in the Immune System - EXIM
SFB 900	(MOBA)
SFB 900	(RDIF)
SFB 900	(VIMM)
SFB 900	(IMCI)
SFB/TR 51	Ecology, Physiology and Molecular Biology of the Roseobacter-Group B04
SFB/TR 51	Ecology, Physiology and Molecular Biology of the Roseobacter-Group C05
SFB/TR 77	(GMAK)
SPP 1258	Sensory and regulatory RNAs in Prokaryotes (Yersinia)
SPP 1316	Host-adapted Metabolism of Bacterial Pathogens (Yersinia)
SPP 1394	Mast-cells – promoters of health and modulators of disease
SPP 1580	Regulation of Rab20
SPP 1617	Bistability rovA Yersinia
SPP 1656	Intestinal Dysbiosis
EXC 62	ReBirth II
FOR 629	Tubulin modifications
FOR 1103	Hund
FOR 1220	PROTRAIN II (TP 11)
FOR 1220	PROTRAIN II (TP 03)
FOR 1406	Exploiting the Potential of Natural Compounds: Myxobacteria
FOR 1406	Tubulysin Derivatives
KFO 250/1	Epigenetics 1
KFO 250/2	Epigenetics 2
Trilateral Cooperation	HR analysis Legionella
D-A-CH Lead Agency Agreement	Phenazine Biosynthesis

Personnel

At the end of 2012 the HZI staff comprised 810 persons with full time and part time occupation. Additionally, 320 guests worked in various projects, receiving their payment from third parties. Along with 210 senior scientists, almost 230 PhD-students were working at the HZI.

Boards and Assemblies of the HZI

The boards and assemblies of the HZI are the Board of Trustees, the Supervisory Board, the Scientific Committee and the Managing Directors.

Board of Trustees

The Board of Trustees is formed by the three trustees of the HZI, the Federal Republic of Germany, the State of Niedersachsen, and the State of Saarland, represented by their respective departments, the Federal Ministry of Education and Research (BMBF), the Finance Ministry of Niedersachsen, and the Ministry of Economics of the Saarland.

Supervisory Board

The Supervisory Board (SB) oversees the legality, expedience and economy of the management. It decides on general research goals, the principal research policy and financial affairs of the centre. It consists of a maximum of 11 members.

Scientific Advisory Committee

The Scientific Advisory Committee (SC) consists of external scientific experts. It advises the Supervisory Board with regard to the R&D programme as well as the general research strategy of the HZI.

Managing Directors

The Managing Directors of the HZI:
 Research & Development: Prof. Dr. Dirk Heinz
 Administration: Ulf Richter, MBA (until 30 Sept. 2013),
 Franziska Broer (from 1 Jan. 2014)

Members of the Supervisory Board (SB) and the Scientific Advisory Committee (SC) (Status: 01.12.2013)

Function	Name, Title	Organisation	Locality
Chairman SB	Brumme-Bothe, MinDir Bärbel	BMBF	Berlin
Vice-Chairman SB	Eichel, MinDir Rüdiger	NMWK	Hannover
SB	Mees, Christian	Staatskanzlei, Saarland	Saarbrücken
SB	Baum, Prof. Dr. Christopher	MHH	Hannover
SB	Buer, Prof. Dr. Jan	Universitätsklinikum	Essen
SB	Gastmeier, Prof. Dr. Petra	Charité	Berlin
SB + SC, Chairman SC	Hardt, Prof. Dr. Wolf-Dietrich	ETH Zürich	Zürich
SB	Lang, Prof. Dr. Christine	Organobalance GmbH	Berlin
SB	Kessler, Wolfgang	HZI	Braunschweig
SB + SC, Vice-Chairman SC	Kisker, Prof. Dr. Caroline	University	Würzburg
SB	Medina, Priv.-Doz. Dr. Eva	HZI	Braunschweig
SC	Autenrieth, Prof. Dr. Ingo	University	Tübingen
SC	Beisiegel, Prof. Dr. Ulrike	University	Göttingen
SC	Brakhage, Prof. Dr. Axel	HKI	Jena
SC	Hesselbach, Prof. Dr. Jürgen	Techn. University	Braunschweig
SC	Ott, Dr. Dr. Melanie	University of California	San Francisco
SC	Rosenthal, Prof. Dr. Walter	MDC	Berlin
SC	Sauer, Prof. Dr. Markus	University	Würzburg
SC	von Mehring, Prof. Dr. Christian	ETH Zürich	Zürich
SC	Waldmann, Prof. Dr. Herbert	MPI Molecular Physiology	Dortmund

Version: 1 Dec. 2013

Scientific Advisory Committee
Prof. Dr. W.-D. Hardt, Chair
WK

Supervisory Board
MinDir'in B. Brumme-Bothe (BMBF), Chair
MinDirig R. Eichel (MWK Niedersachsen), Vice Chair
AR

Steering Committee
LA

Council of Scientists
Prof. Dr. S. Häußler, Chair
WISKO

Scientific Management
Administrative Management
Prof. Dr. D. Heinz
N.N.
GFW
GFA

Staff Council
J. Aubert, Chair
BR

Equal Opportunity Commissioner
E. Rohn-Stenzel
GB

Represent. Body for Disabled Employees
E. Reinhard
VPS

Occupational Re-entry Management
B. Jaschok-Kentner
BEM

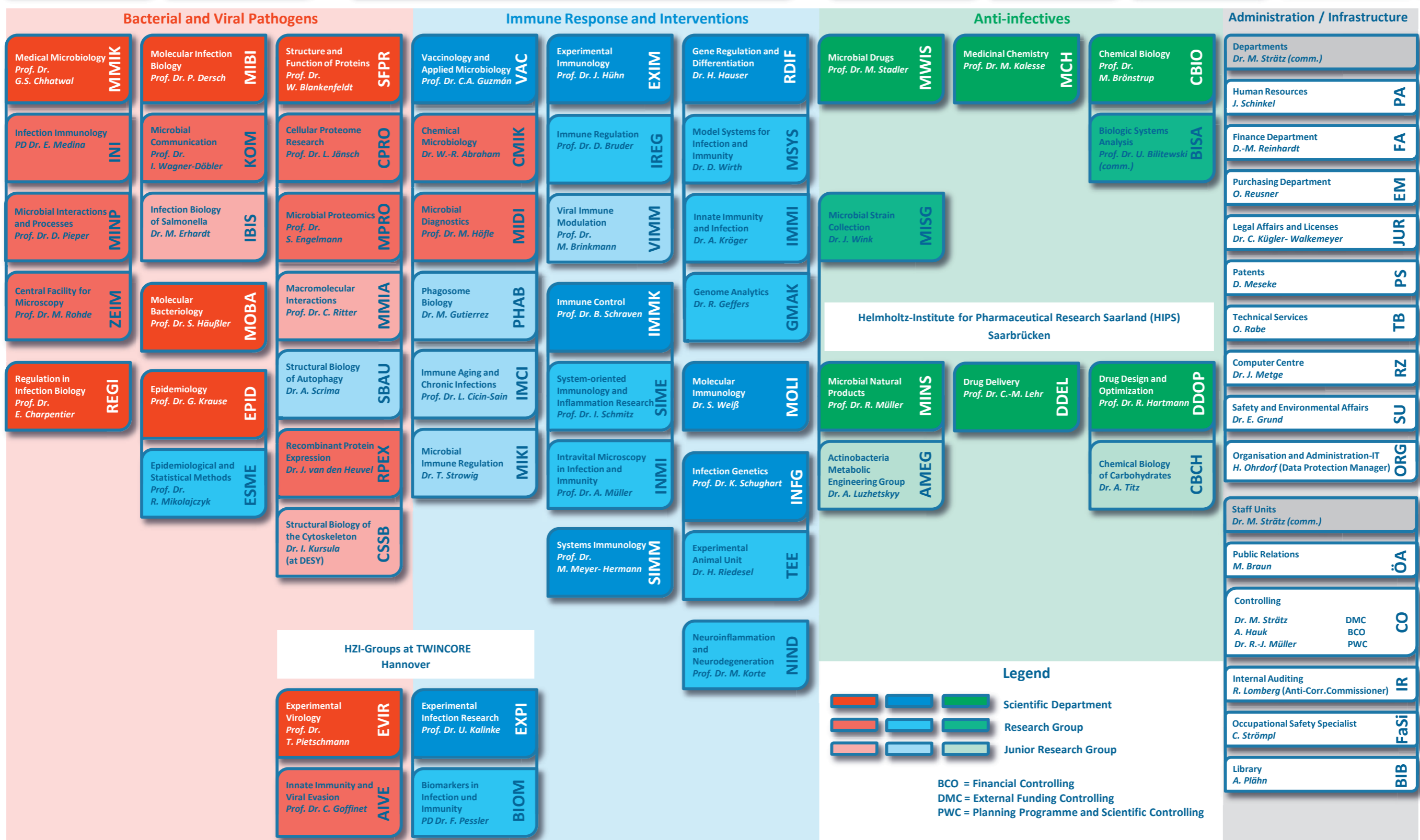

Annual Report 2012/2013

Published by

Helmholtz Centre for Infection Research GmbH. (HZI)

Inhoffenstraße 7 | D-38124 Braunschweig, Germany

Telephone +49 531 6181-0 | Fax +49 531 6181-2655

info@helmholtz-hzi.de | www.helmholtz-hzi.de

Member of Helmholtz Association of National Research Centres (HGF)

Editor-in-Chief: Prof. Dr. Rainer Jonas (V.i.S.d.P.) | rainer.jonas@helmholtz-hzi.de

Editorial Assistance: Monica Kirchner, Public Relations Department

Text Editing and Realisation: Dr. Jo Schilling | buero@jo-schilling.de

Translations: Ronning Übersetzungsdienst Muttersprachler & team

English Proofreading: Paul Charlton – PCC

© 2013 HZI Braunschweig

Photographs

The portraits and further photos, all belonging to the HZI, were taken by

Airborne Images.com – pages 2, 5, 16, 17, and were partially used on the pages 4-89, 252/3

Schmitt – pages 10, 100, 101, 134, 135 164, 236, 239-243

Hallbauer & Fioretti – pages U1, U2, 18, 28, 33, 40, 48, 49, 51, 54-57, 60-65, 74, 75, 77, 84-87, 92, 97-99, 102-105, 108-111, 114-127, 129-131, 140, 141, 146-157, 161-163, 166-169, 176-179, 186, 187, 190, 191, 194-197, 202, 203, 206-216, 218-221

Gramann – pages 62, 252

Unruh – pages U3, 222, 223

HZI collection – pages: U2, U3, U4, 2, 3, 6, 13, 38, 72, 90, 91, 96, 106, 107, 112, 113, 136, 137, 144, 145, 158, 159, 170, 174, 175, 204, 205, 217

Studienzentrum Hannover – pages 50, 52, 53, 126, 127

HIPS collection – pages: 34, 39, 180-182, 188, 189, 193, 193, 198-201

Twincore collection – pages: 165, 171, 236-243

DZIF collection – pages: 244, 245

The following portraits were made available by the authors – pages: 80, 81 (Luzhetskyy), 88, 89 (Titz), 128 (Charpentier), 132, 133 (Kursula), 160 (Meyer-Hermann), 172 (Korte)

For all other photographs, the authors and/or institutions are mentioned below the legends.

Layout and design

UNRUH Designbüro, Braunschweig | unruh@unruhdesign.de | www.unruhdesign.de

Printed by

döringDruck | Druckerei und Verlag GmbH | Koppestraße 6 | 38104 Braunschweig



The HZI Campus

- A, B, C, D, GZ Research Labs
- B2 Drug research & Functional genomics (planned)
- D2 Offices
- E, F, H, K, Q, R, U Infrastructure
- S3 S3-Facility
- T, T2 Animal Facility
- N Infrastructure & Administration
- VC Administration
- W Administration, Library, Canteen
- X „Forum“ – Event & Seminar Building
- Y Research Labs, Fraunhofer ITEM
- Z Leibniz Institute DSMZ



ISSN 1865-9713

Helmholtz-Zentrum für Infektionsforschung GmbH
Inhoffenstraße 7 | D-38124 Braunschweig
www.helmholtz-hzi.de | info@helmholtz-hzi.de

